

CUADERNILLO DE SÍLABAS



Alumno (a): _____

Grado: _____ Grupo: _____ Turno: _____

Maestro (a): _____

Escuela: _____

Actividad: Indicar al alumno el trazo correcto de las siguientes vocales.

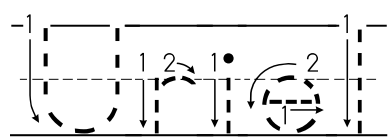
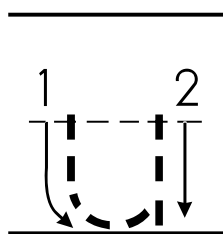
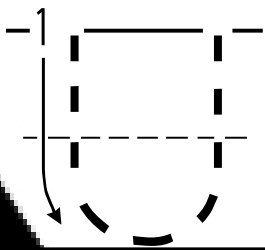
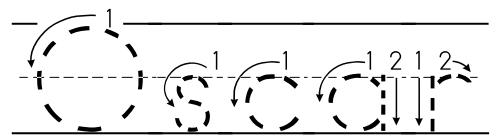
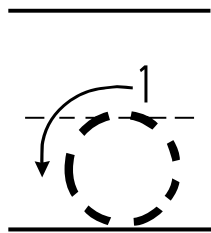
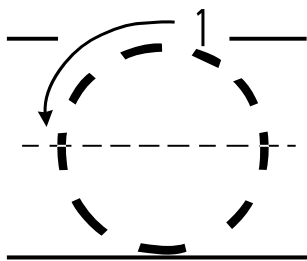
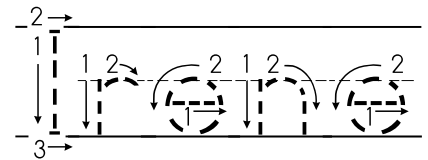
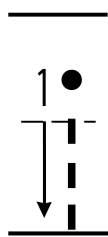
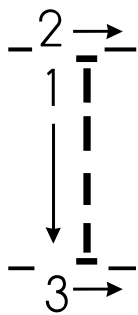
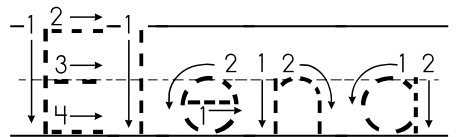
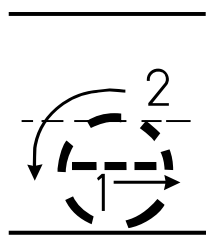
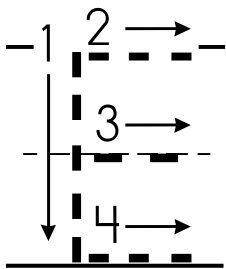
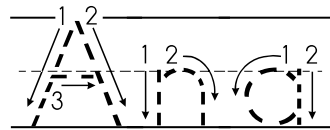
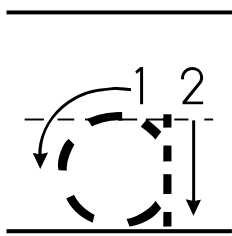
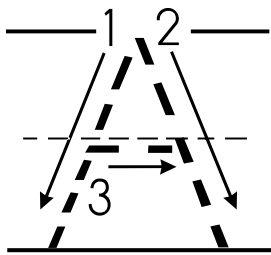

Actividad: Repasa y remarca las sílabas de la m.

ma mi me mo mu

ma mi me mo mu

ma mi me mo mu

ma mi me mo mu

ma mi me mo mu

ma mi me mo mu

ma mi me mo mu

ma mi me mo mu

ma mi me mo mu



Actividad: Lee la silaba y tacha el dibujo que inicia con la misma.

mo

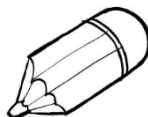
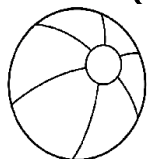

ma



mu



mi



me

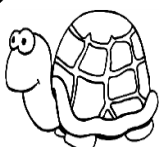

Actividad: Remarca y repasa las sílabas, pega la imagen en el segundo rectángulo que tenga al inicio de la palabra la sílaba y en el último la sílaba inicial.

ma ma ma

me me me

mi mi mi

mo mo mo

mu mu mu

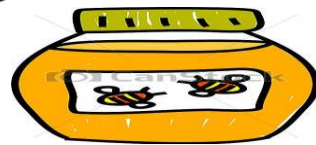

ma



mu

me

mo

mi

Actividad: Remarca y repasa las sílabas en voz alta.

Ss

sa se

si so

su

sa sa sa sa sa sa

se se se se se se

si si si si si si

so so so so so so

su su su su su su

su su su su su su



Actividad: Remarca y repasa las silabas que estan en los rectangulos y pega la imagen con su silaba inicial.

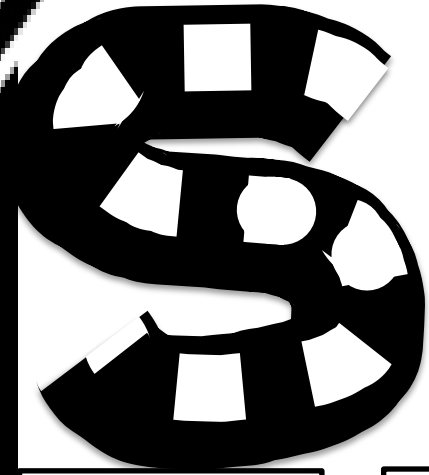

so

pegar

si

pegar

so

pegar

sa

pegar

se

pegar

so

pegar

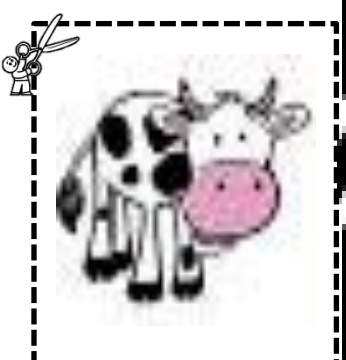
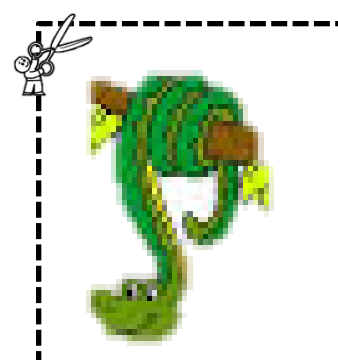

Actividad: Lee la silaba , arma el rompecabezas con la silaba que comienza cada dibujo.

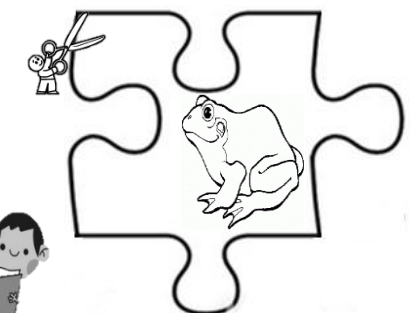
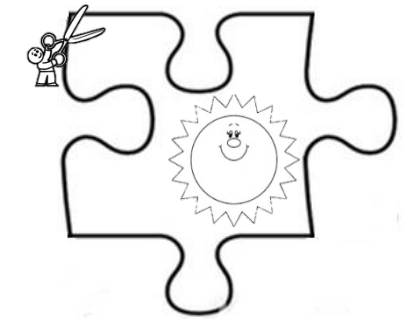
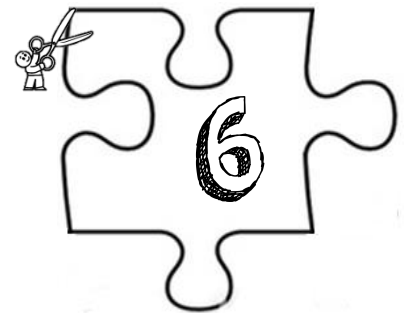
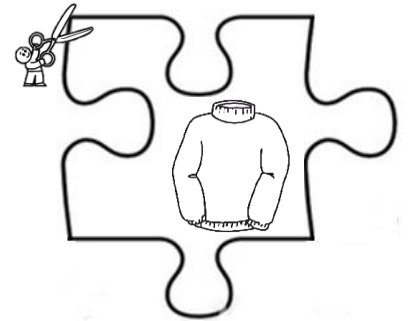
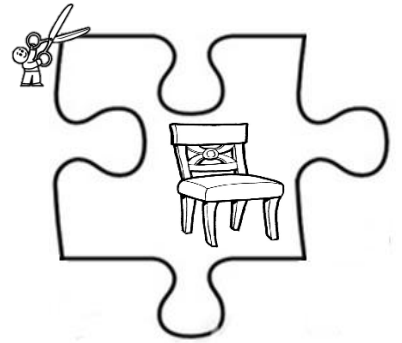
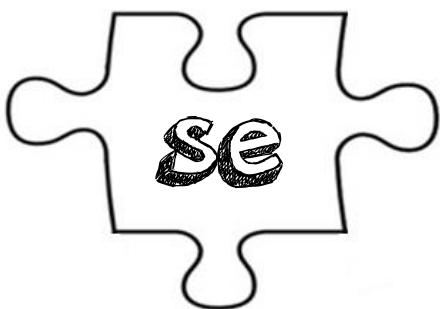
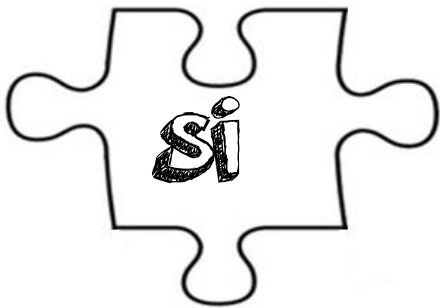
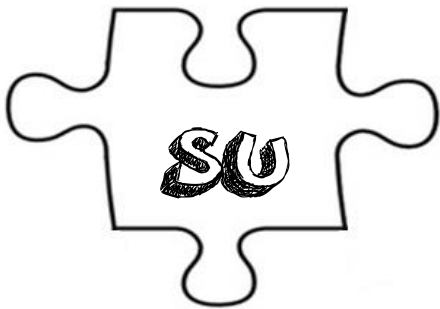
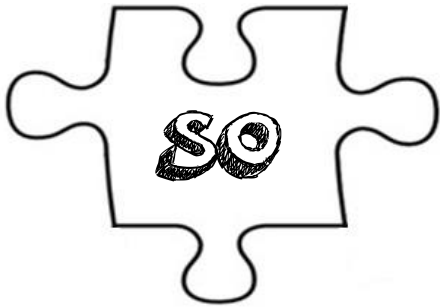
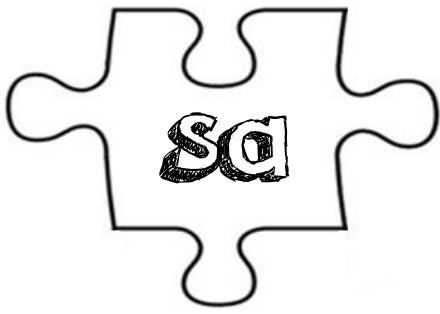

Actividad: Remarca la letra "T" y las palabras.

Tito

Tania

Tatiana

Tamara

Tomás

Tommy

Teresa

Tadeo

Toribio

Tony

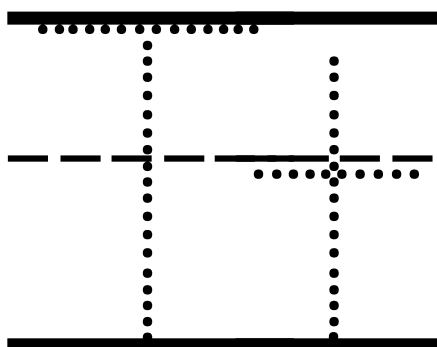
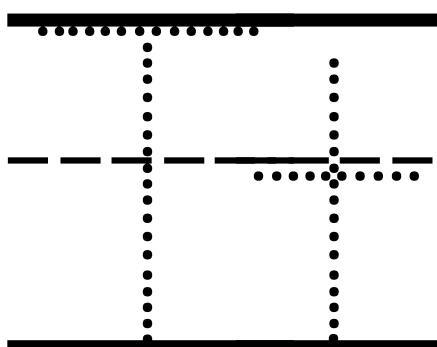
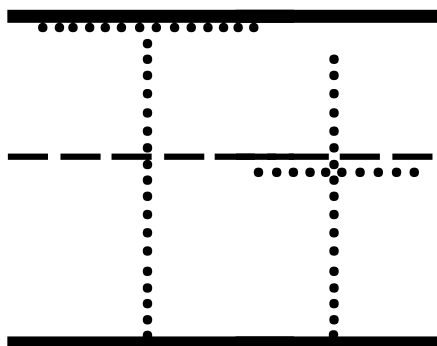

Actividad: Recorta las silabas de abajo y pega la silaba inicial de cada palabra.

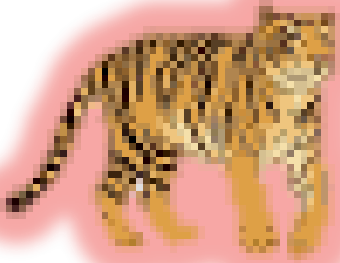

pegar



pegar



pegar

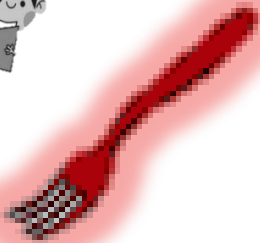

pegar



pegar



pegar



ta

te



ta

te

ta

ti

ta

Actividad: Repasa y remarca las sílabas, recorta y pega las imágenes de acuerdo con la sílaba que inicia.

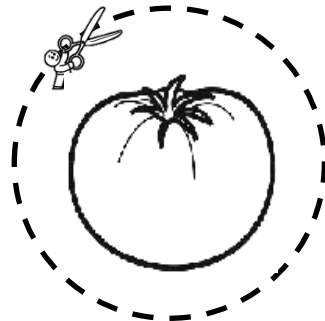
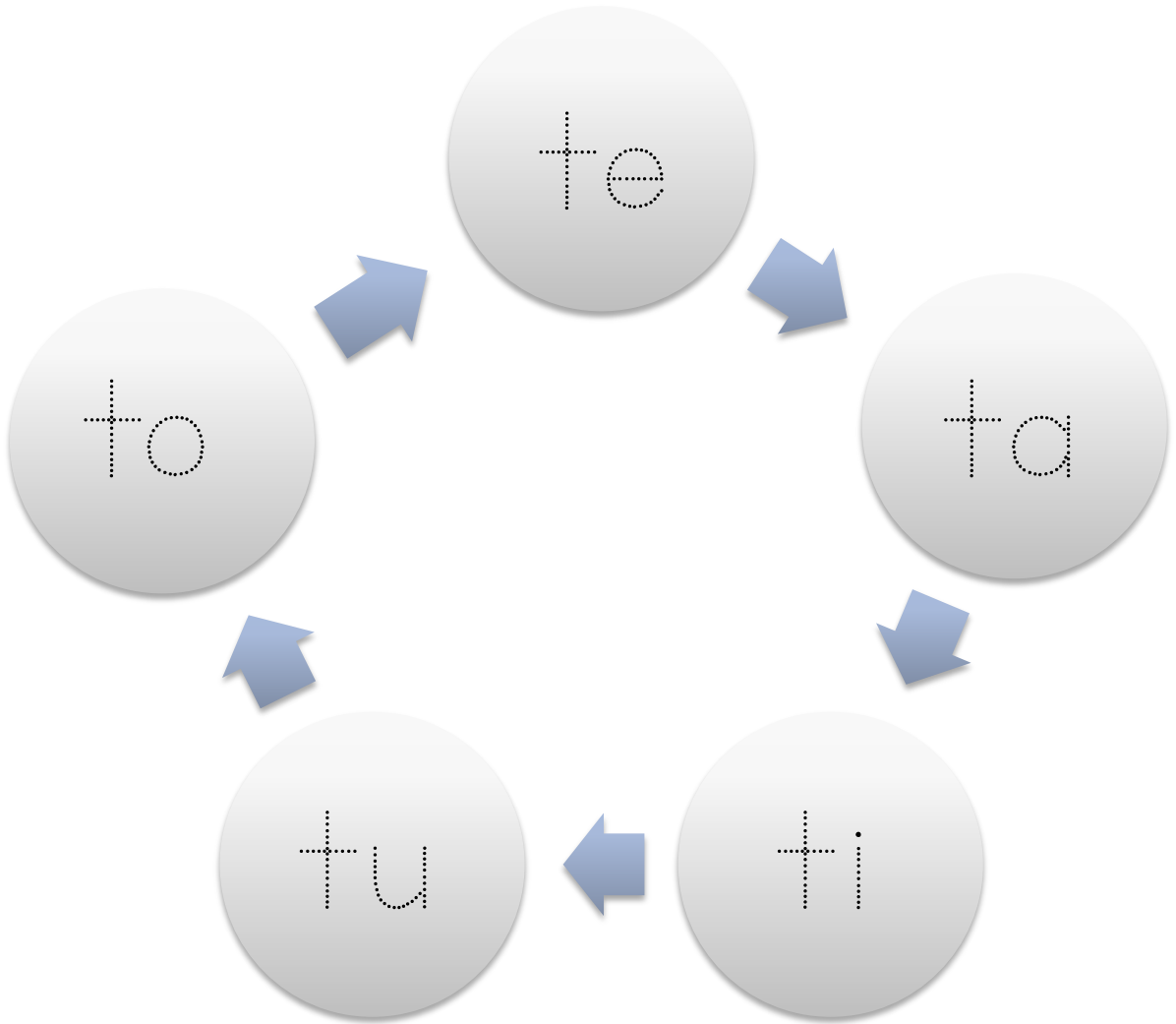

Actividad: Recorta y arma los rompecabezas en tu libreta, lee al finalizar la palabra armada.

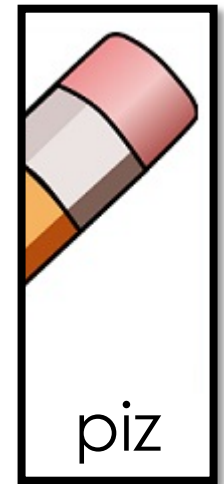

Actividad: Colorea la línea que contenga la sílaba con la que inicia el nombre del dibujo.



----->

la

----->

lo



----->

la

----->

lu



----->

le

----->

li



----->

lo

----->

le



----->

la

----->

lu

Actividad: Repasa y remarca las silabas, arma el rompecabezas con la silaba que inicia la imagen.

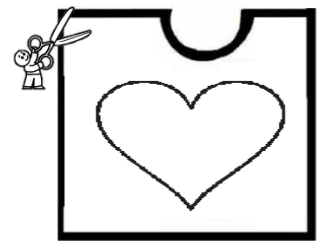
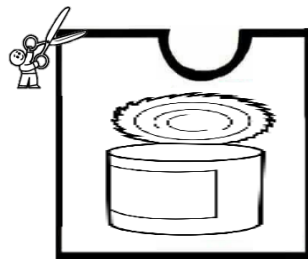
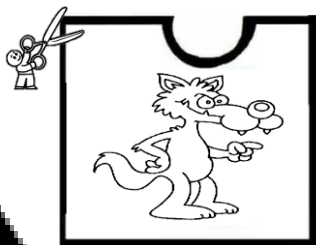
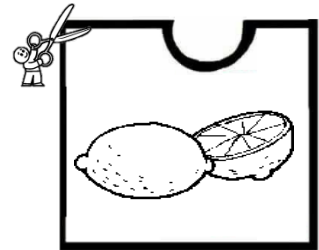
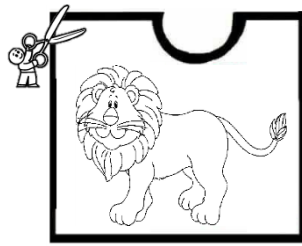
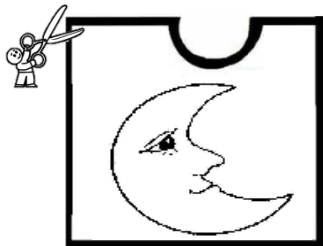
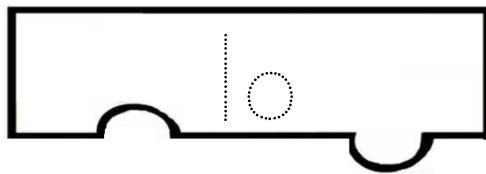
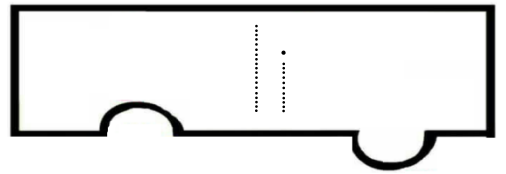
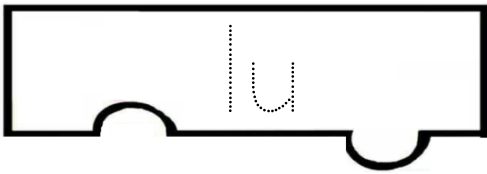
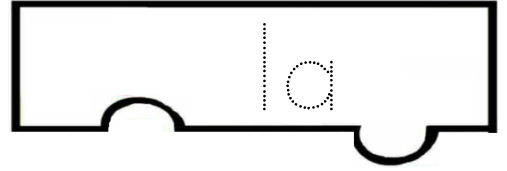
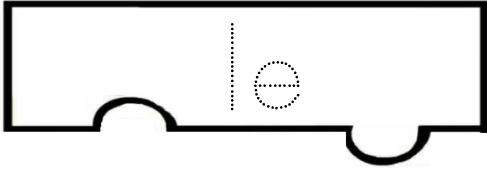

Actividad: Observa las imágenes, remarca y repasa las sílabas y pégalas de acuerdo con la sílaba que inicia el nombre del dibujo.



pega



pega

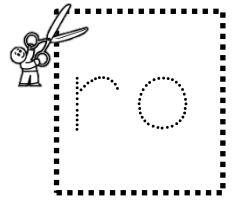

pega



pega

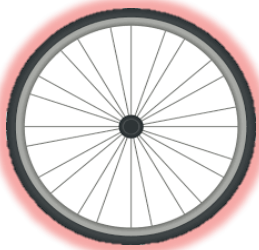
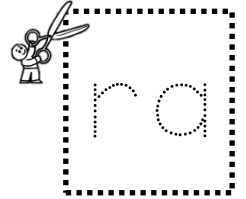
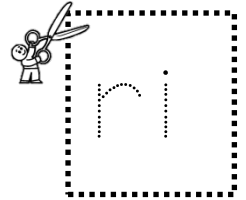

pega

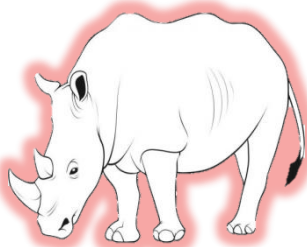
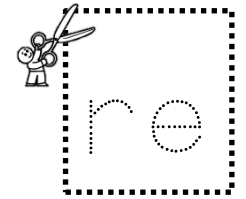

pega

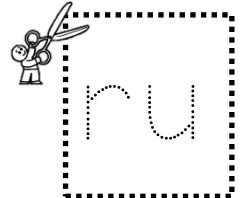

pega

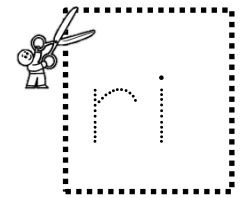

Actividad: Arma los rompecabezas, relaciona la imagen con la palabra correcta y pega en tu libreta los pares.

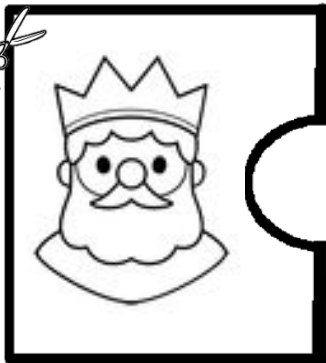
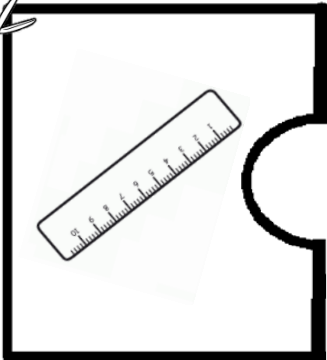
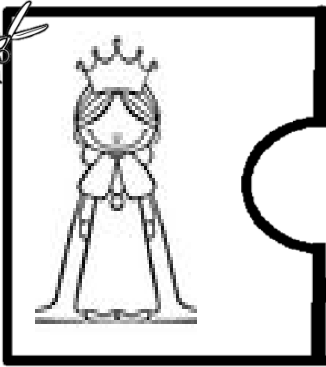

pama

reyna

risa

regla

rey

regalo

Actividad: Lee las oraciones y remarca la palabra punteada ,une con una línea la imagen que corresponda.

1.- Una rana juega en el agua.



2.- En el castillo vive un rey.



3.-El niño juega con una raqueta.



4.- Una rueda de piedra.



5.- En el río las personas se bañan.



Actividad: Remarca la silaba inicial de cada imagen.

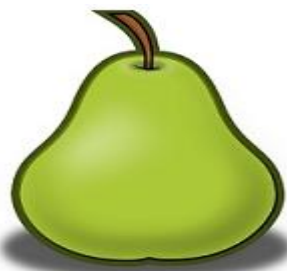

pa-pe-pi-po-pu



pa-pe-pi-po-pu



pa-pe-pi-po-pu



pa-pe-pi-po-pu



pa-pe-pi-po-pu

Actividad: Observa las imágenes, recorta la silaba inicial de los dibujos y pega correctamente. Colorea al finalizar.

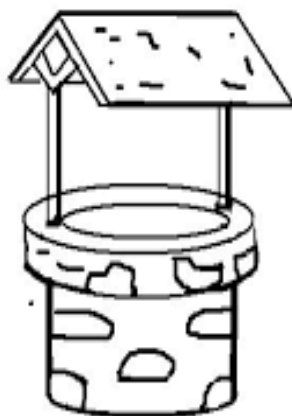

pega

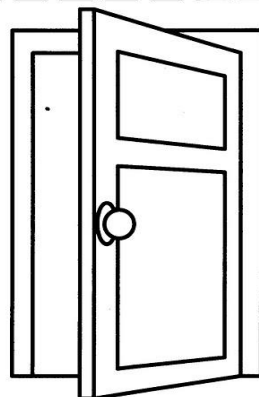

pega



pega

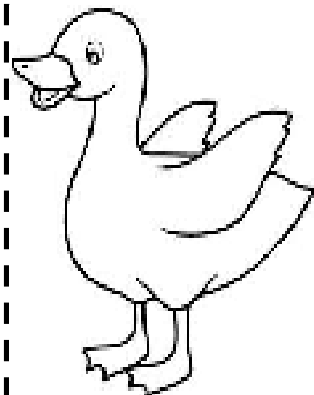

pega



pega



pa



pe



pi



po



pu

Actividad: Lee las palabras que están en el círculo, recorta y pega las imágenes donde corresponda de acuerdo al nombre.

papaya

paleta

payaso

peine

pie

pez

pelota

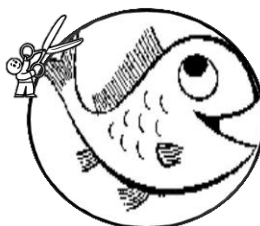
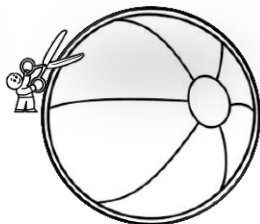
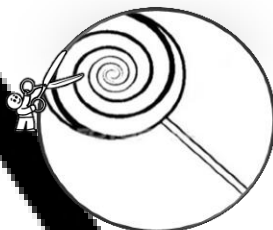
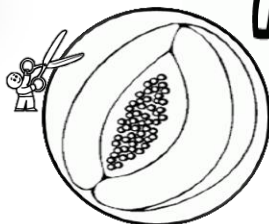
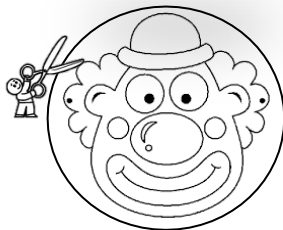
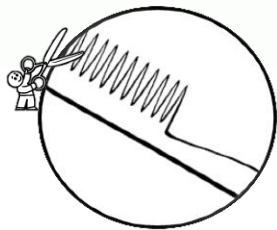

Actividad: Recorta las palabras y pégalas donde corresponda al nombre del dibujo.

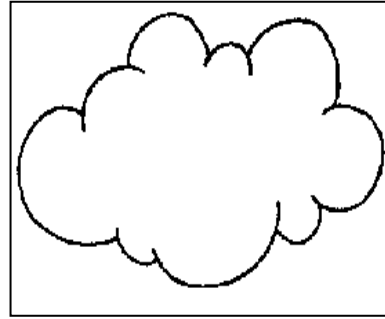
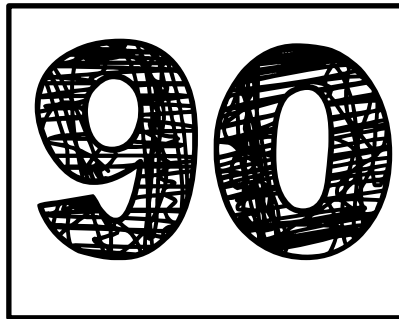
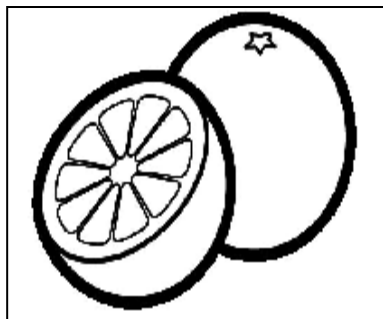

pega

pega

pega

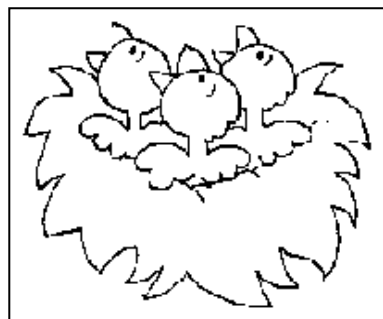

pega

pega

pega

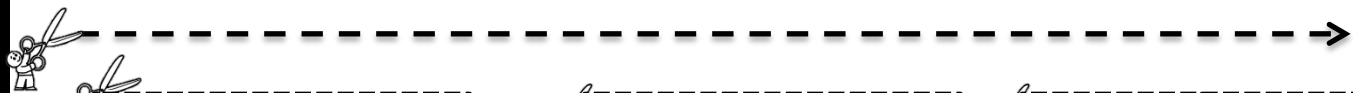

noventa

nene

nube

naranja

nave

nido

Actividad: Recorta las palabras y pégalas donde corresponda al nombre del dibujo.

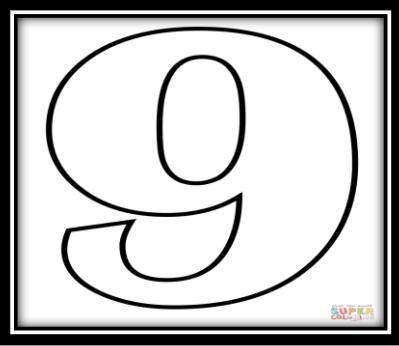

pega

pega

pega

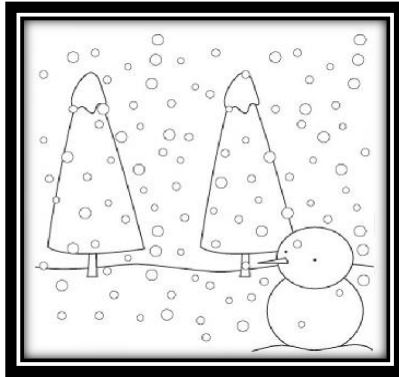
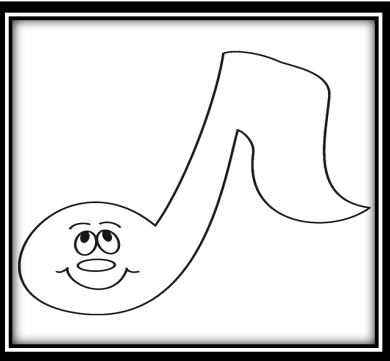

pega

pega

pega

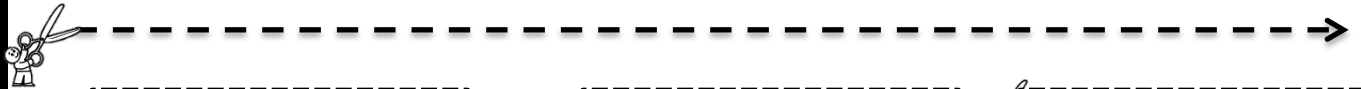

niña

nadar

nota

nieve

nueve

noche

Actividad: Remarca la letra "d" y repasa las silabas.

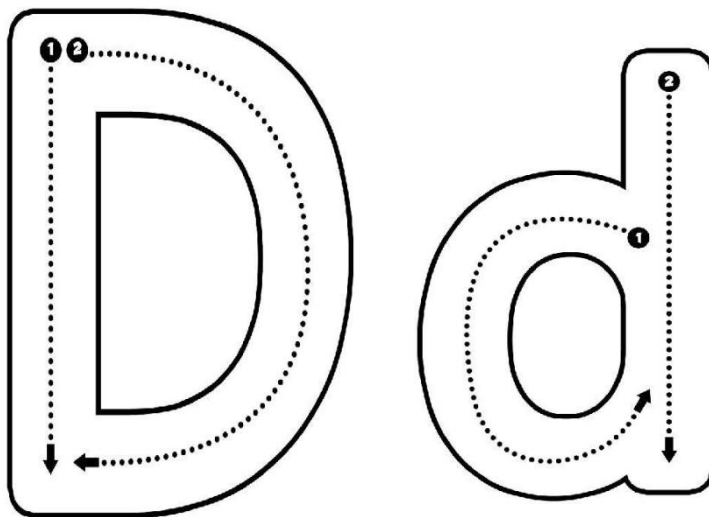

da da

de de

di di

do do

du du

da da

de de

di di

do do

du du

da da

de de

di di

do do

du du

da da

de de

di di

do do

du du

da da

de de

di di

do do

du du

da da

de de

di di

do do

du du

Actividad: En las siguientes imágenes , colorea el rectángulo que tenga la sílaba con la que inicia el nombre de los dibujos.

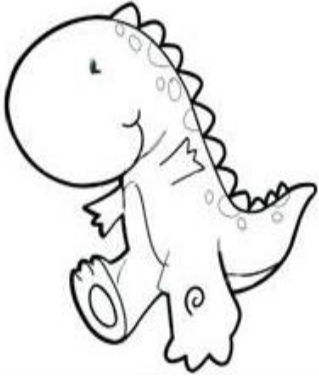

do di

de du

di da

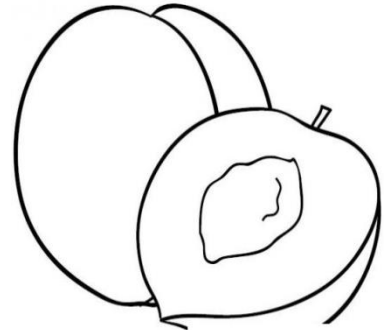
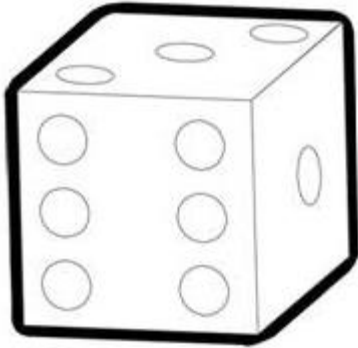

de da

di du

di du

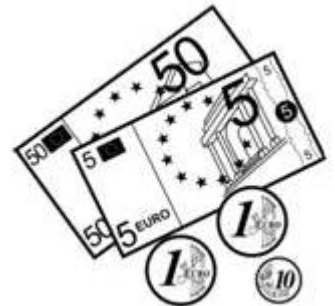
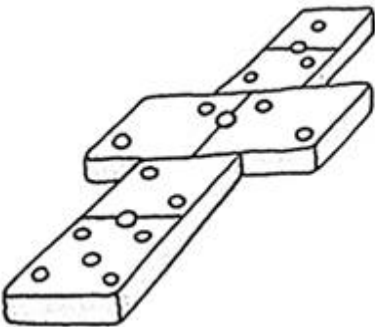

do de

da du

du di

Actividad: Lee y remarca las siguientes palabras, subraya las palabras que tengan las letras "d"



El niño hace deporte.



El dulce es rico.

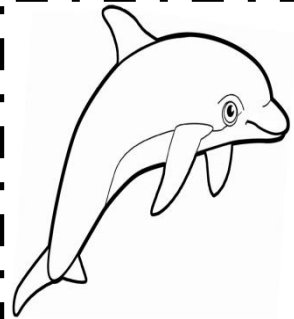

El delfín nada en el mar.



La dona es muy rica.



Ana visita a la doctora.

Actividad: Remarca la letra "b" y repasa las silabas.

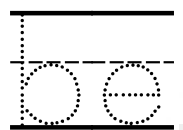
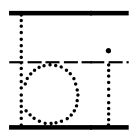
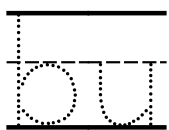
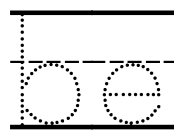
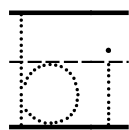
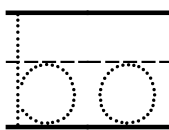
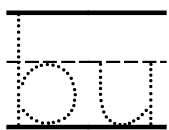
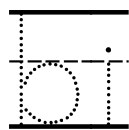
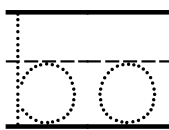
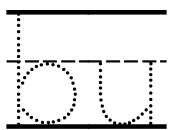
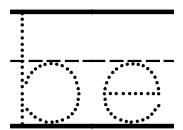
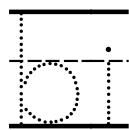
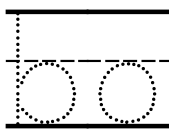
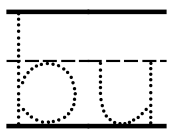
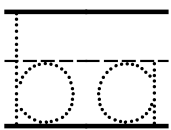
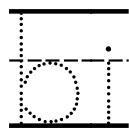
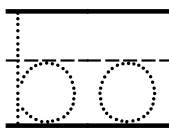
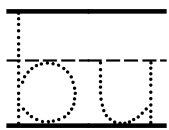
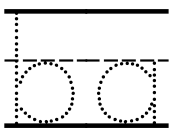
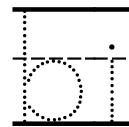
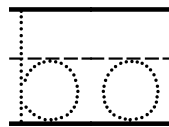
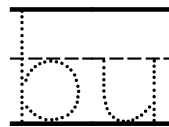
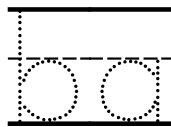
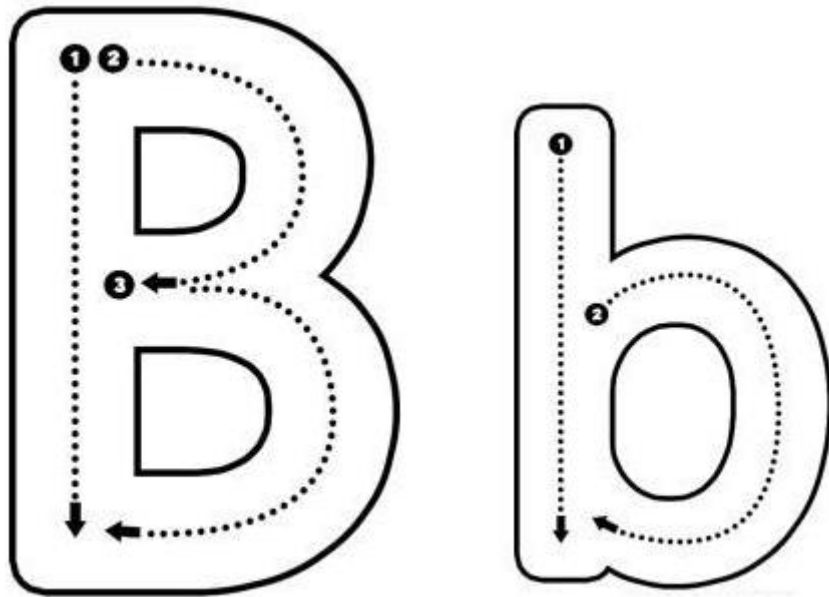

Actividad: Une con una línea la imagen con la estrella que contenga la sílaba con la que inicia.

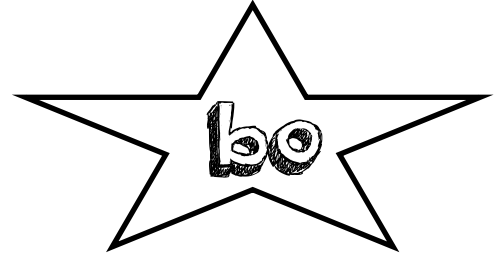

Actividad: Colorea la imagen y la nube del mismo color, para que coincidan con el nombre de la imagen.

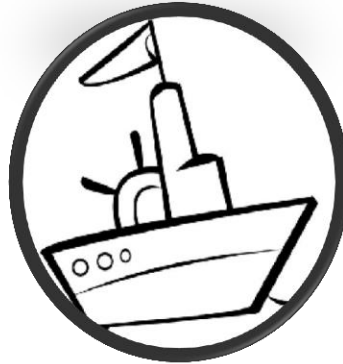

beso

bigote

botella

barco

balón

bolsa

bebé

Actividad: Recorta las líneas punteadas, dobla y pega en tu libreta. Recorta las imágenes y mételas de acuerdo al inicio de cada palabra ya sea en "b" o "d". Escribe las palabras en la línea.

"b"

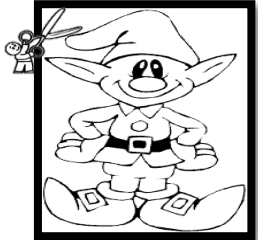
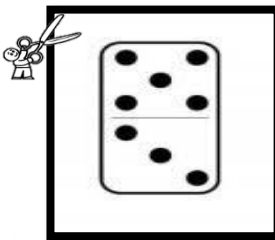
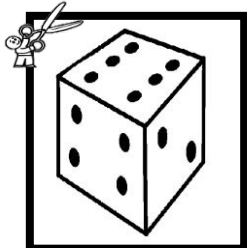
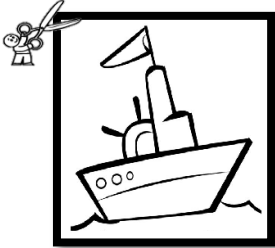
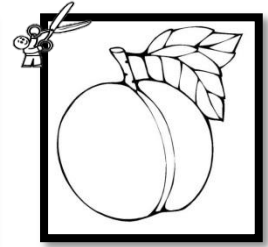
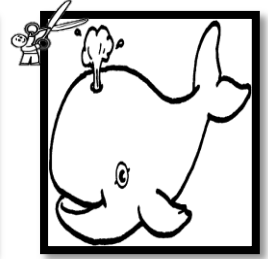
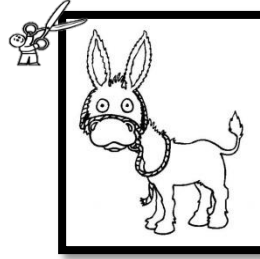

"d"

Actividad: Remarca la letra "f", y repasa las sílabas.

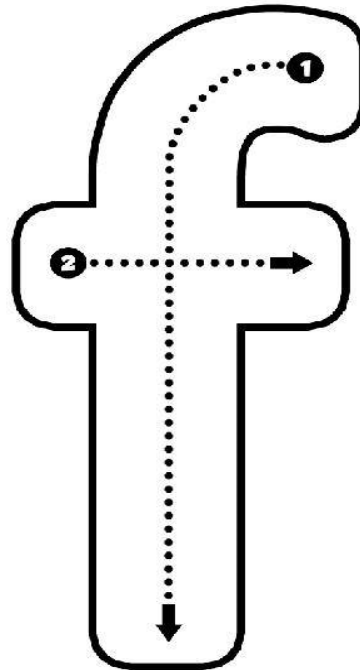
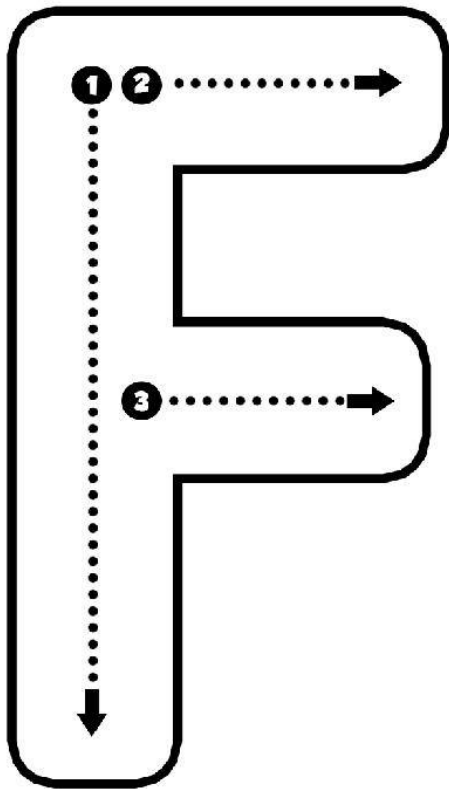

fa

fe

fi

fo

fu

fa

fe

fi

fo

fu

fa

fe

fi

fo

fu

fa

fe

fi

fo

fu

fa

fe

fi

fo

fu

Actividad: En cada imagen hay dos silabas, remarca la silaba que indica el inicio del nombre de la imagen.

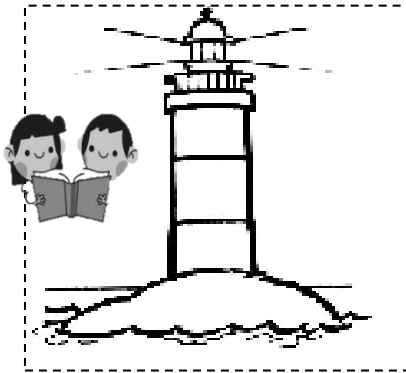

fu

fa

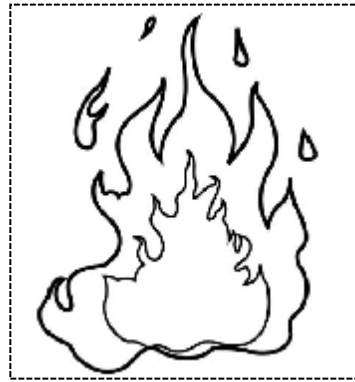

fu

fa



fi

fo



fe

fu

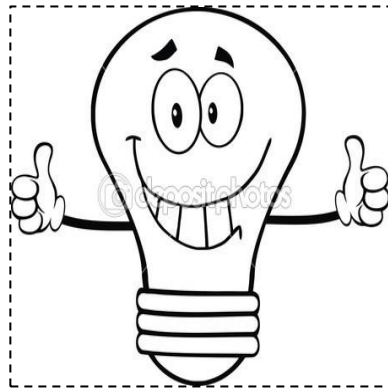

fe

fo



fe

fu



fi

fo

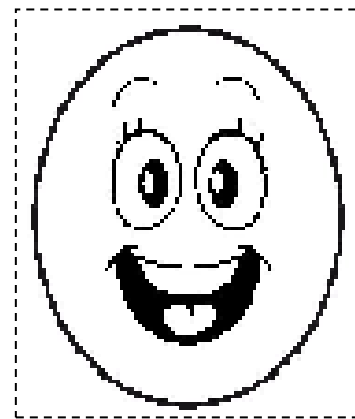

fe

fu

Actividad: Lee y remarca las palabras que están punteadas, subraya con color rojo las sílabas de la familia de la letra "f".

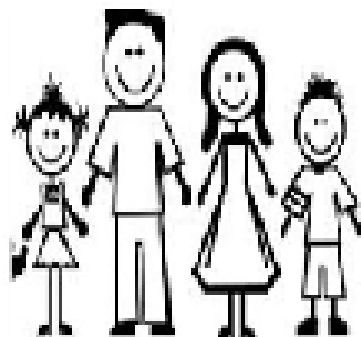

familia



fútbol

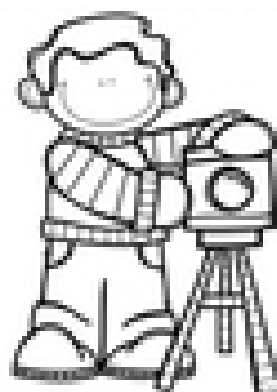
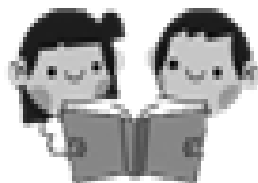

fotógrafo

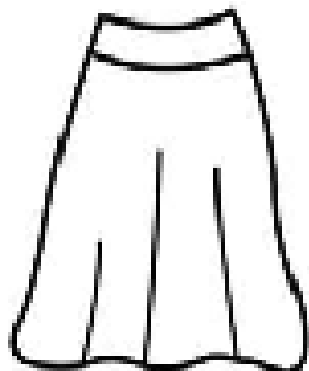

falda

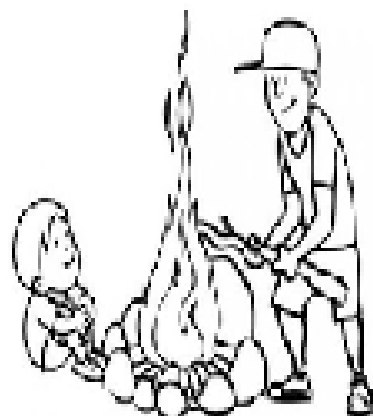

fogata

Actividad: Actividad: En voz alta di el nombre de la imagen y tacha la sílaba con la que empiezan sus nombres.

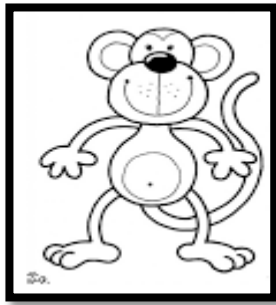

mi mo



le la

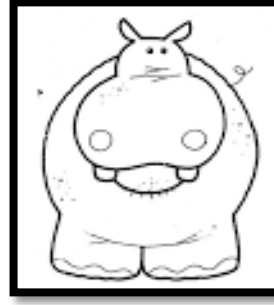

hi li



ji si

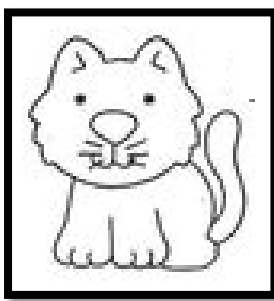

ga ja

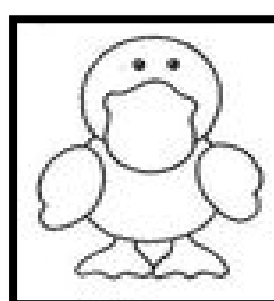

pa sa

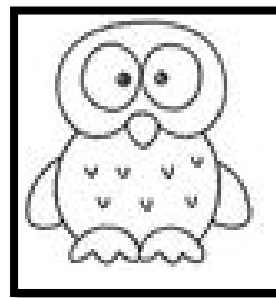

so bu

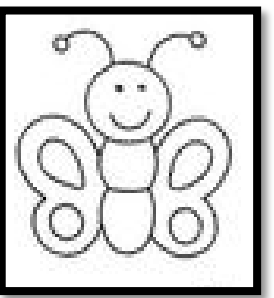

ma su

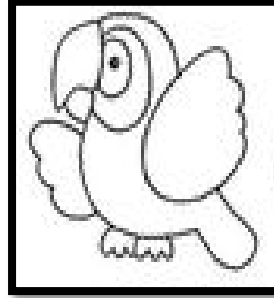

co si

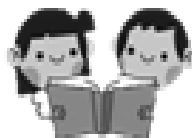

Actividad: Colorea las imágenes que inician con la letra "j".

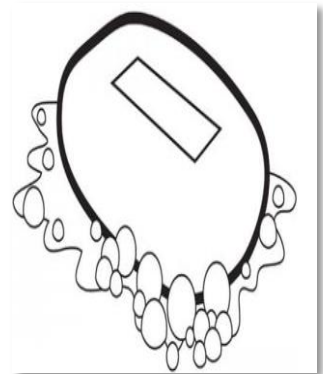
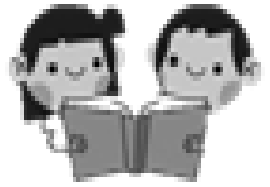
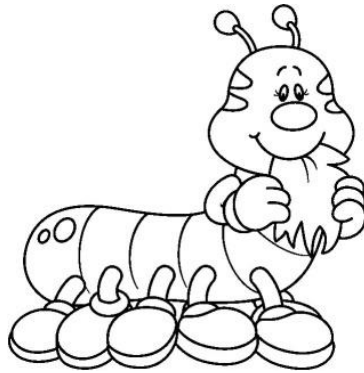

Actividad: Colorea la burbuja que contenga el nombre de la imagen.

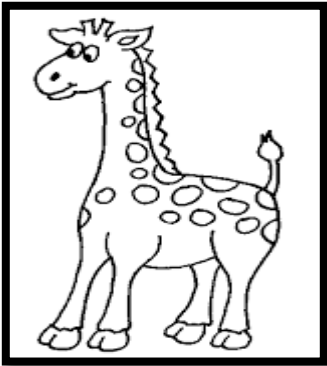

jabón

jirafa

jaula



globo

jirafa

jarra



jorobado

girasol

gusano



uva

fresa

juguete

jaguar

foca

jeringa

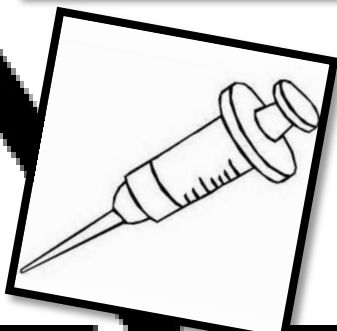

Actividad: Remarca y lee las oraciones. Encierra las palabras que tengan la letra "j".



El jinete monta un
caballo.



El niño se llama
Jesús.

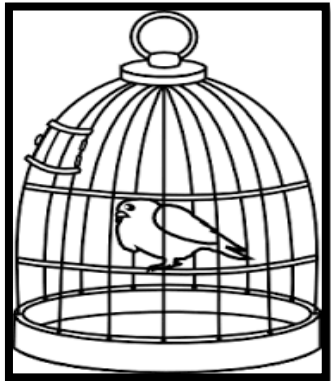

Un pájaro en la jaula.

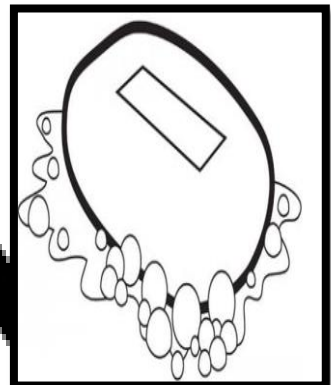

Yo me baño con jabón
y agua.

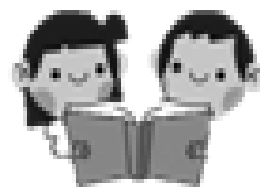

Actividad: Remarca y lee las oraciones, coloca la imagen que corresponda a la oración.

Un volcán en la isla.



El venado es bonito.

pega

Hay mucho viento afuera.

pega

Una vaca en el campo.

pega

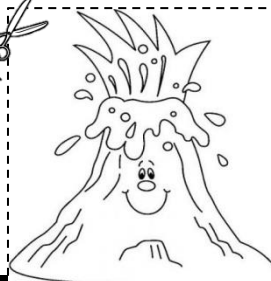
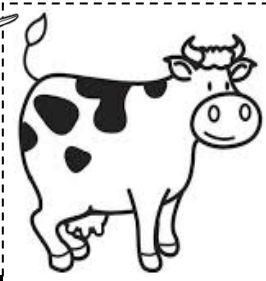
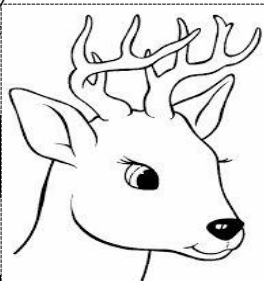

Actividad: Recorta y pega la silaba que hace falta para completar la palabra.



a pega ón



pega la



pega no



pega tilador

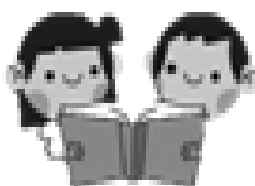

u pega



llu pega a

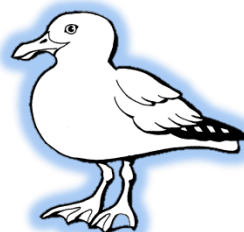

ga pega eta

 vi vi

 vi ve vi ve va

Actividad: Escribe a las imágenes su nombre correctamente, apóyate en el rectángulo de la izquierda.

caballo

cuchara

cerdo

pera

cuna

coco

manzana

cereza

cisne

perro

cinturón

uva

cuarenta

ojo

calabaza

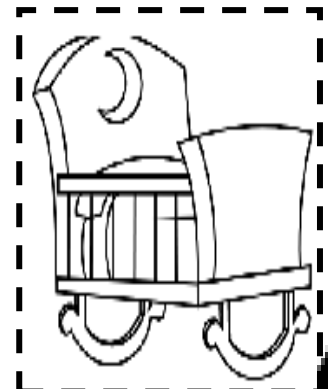
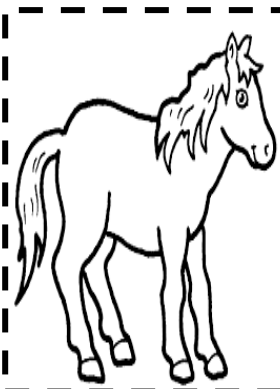
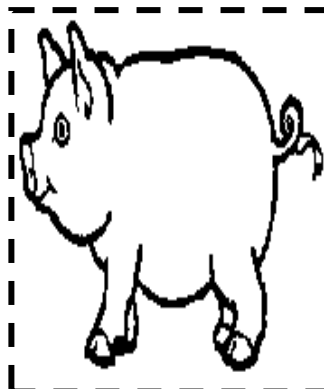
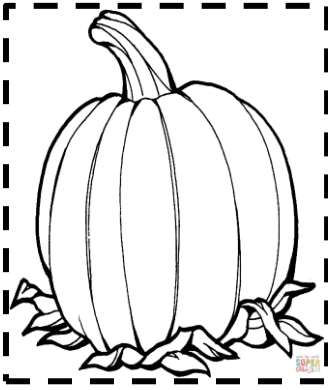
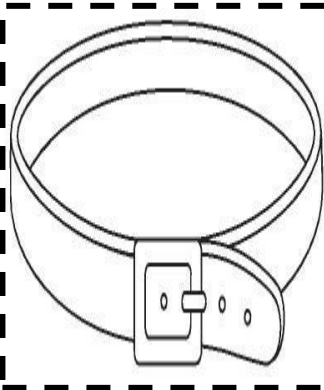
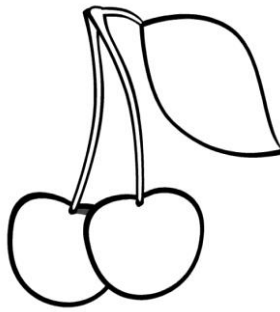
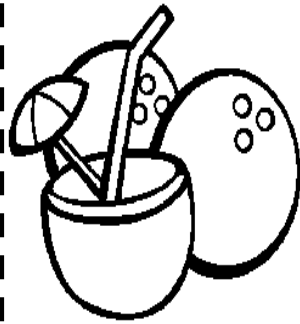

Actividad: En cada imagen hay dos silabas, remarca la silaba que indica el inicio del nombre de la imagen.

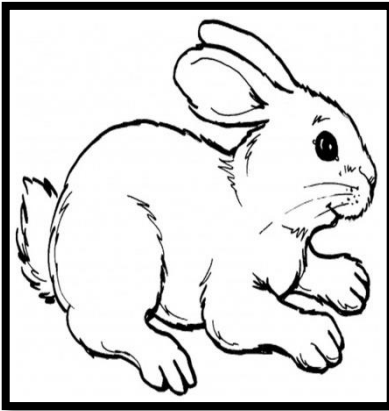

ca

co

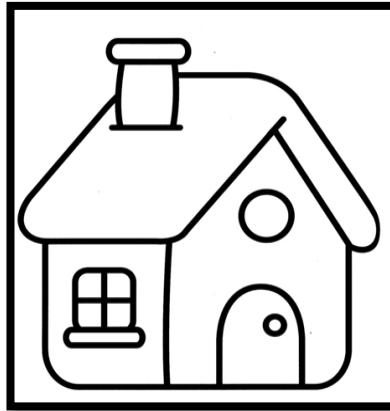

cu

ca

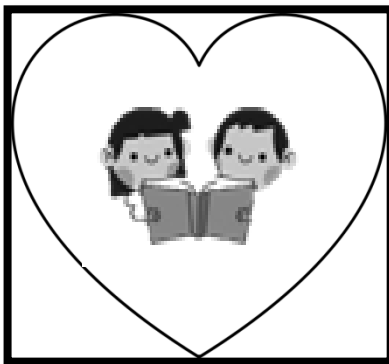

co

cu



ce

ca

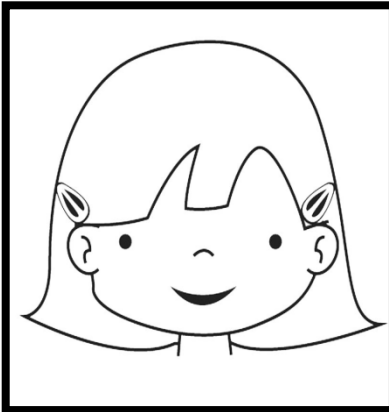

ca

ce

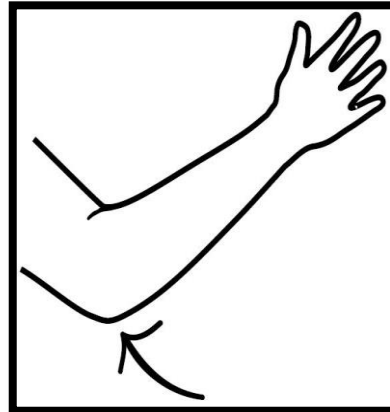

co

ci

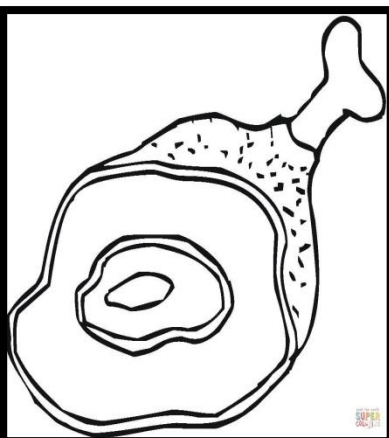

ci

ca

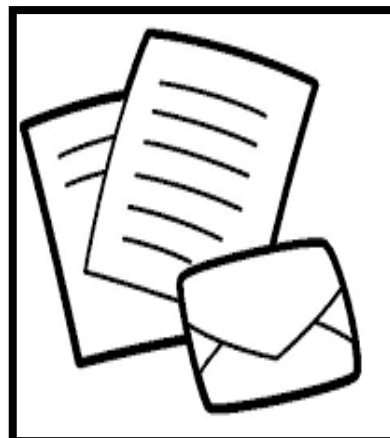

ca

cu

Actividad: Utiliza tu alfabeto móvil y construye los nombres de los siguientes animales.

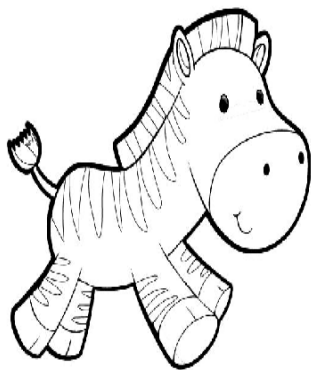

□ □ □ □ □

Nº de letras

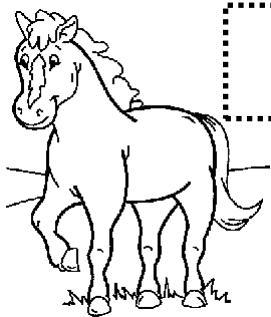

□ □ □ □ □ □ □

Nº de letras

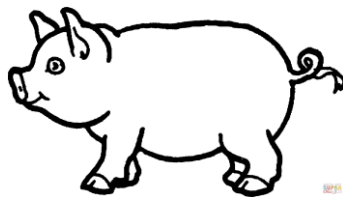

Nº de letras

□ □ □ □ □ □ □



Recorta las letras y pega.

| | | | | | | | |
|---|---|---|---|---|---|---|---|
| c | h | n | e | c | a | c | o |
| b | a | l | a | r | b | o | i |
| o | l | c | | | | | |

Actividad: Colorea las silabas para formar el nombre de la imagen

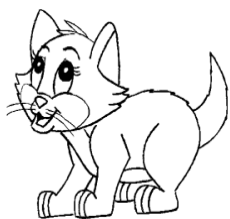

ga sa to la

ga lli si na

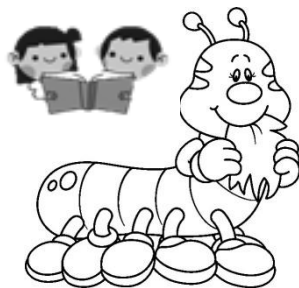
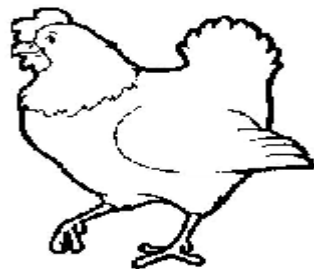

ga gu sa no

go su ri la

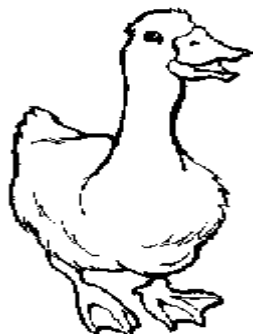

go gan to so

go ma rra mi



ge la ni o



Actividad: Recorta las letras y arma las palabras. Colorea al finalizar.







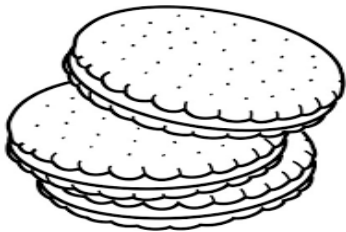



A grid of 27 dashed boxes containing letters for a word-building activity. The letters are arranged as follows:

| | | | | | | | | |
|---|---|---|---|---|---|---|---|---|
| o | t | g | a | a | t | g | e | a |
| l | e | l | i | g | r | a | s | o |
| g | l | t | a | i | a | n | | |

Actividad: Remarca y repasa las sílabas de la letra "h".

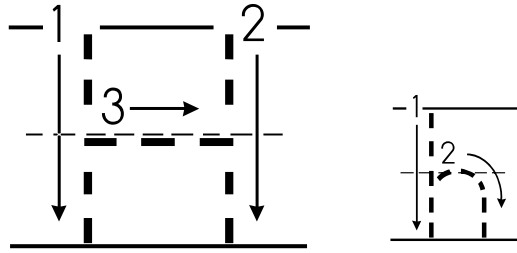

| | | | | |
|--|--|--|--|--|
| | | | | |
| | | | | |
| | | | | |
| | | | | |
| | | | | |
| | | | | |
| | | | | |
| | | | | |

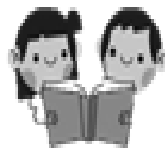

Actividad: De las dos palabras remarca con cualquier color el nombre correcto de la figura.



Tracing practice for the word "chimenea" (chimney). The letters are dashed with numbered arrows indicating stroke order: 'c' (1 down, 2 curve), 'h' (1 down, 2 curve), 'i' (1 down, 2 curve), 'e' (1 down, 2 curve), 'n' (1 down, 2 curve), 'e' (1 down, 2 curve), and 'a' (1 down, 2 curve).

Tracing practice for the word "humo" (smoke). The letters are dashed with numbered arrows indicating stroke order: 'h' (1 down, 2 curve), 'u' (1 down, 2 curve), 'm' (1 down, 2 curve, 3 curve), and 'o' (1 down, 2 curve).



Tracing practice for the word "hoja" (leaf). The letters are dashed with numbered arrows indicating stroke order: 'h' (1 down, 2 curve), 'o' (1 down, 2 curve), 'j' (1 down, 2 curve), and 'a' (1 down, 2 curve).

Tracing practice for the word "nija" (niece). The letters are dashed with numbered arrows indicating stroke order: 'n' (1 down, 2 curve), 'i' (1 down, 2 curve), 'j' (1 down, 2 curve), and 'a' (1 down, 2 curve).

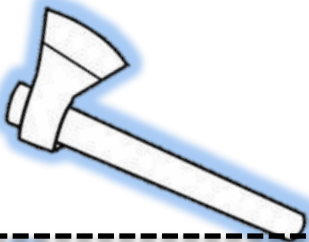

Tracing practice for the word "hacha" (axe). The letters are dashed with numbered arrows indicating stroke order: 'h' (1 down, 2 curve), 'a' (1 down, 2 curve), 'c' (1 down, 2 curve), 'h' (1 down, 2 curve), and 'a' (1 down, 2 curve).

Tracing practice for the word "hola" (hello). The letters are dashed with numbered arrows indicating stroke order: 'h' (1 down, 2 curve), 'o' (1 down, 2 curve), 'l' (1 down, 2 curve), and 'a' (1 down, 2 curve).



Tracing practice for the word "niña" (girl). The letters are dashed with numbered arrows indicating stroke order: 'n' (1 down, 2 curve), 'i' (1 down, 2 curve), 'ñ' (1 down, 2 curve), and 'a' (1 down, 2 curve).

Tracing practice for the word "noda" (note). The letters are dashed with numbered arrows indicating stroke order: 'n' (1 down, 2 curve), 'o' (1 down, 2 curve), 'd' (1 down, 2 curve), and 'a' (1 down, 2 curve).



Tracing practice for the word "helado" (ice cream). The letters are dashed with numbered arrows indicating stroke order: 'h' (1 down, 2 curve), 'e' (1 down, 2 curve), 'l' (1 down, 2 curve), 'a' (1 down, 2 curve), 'd' (1 down, 2 curve), and 'o' (1 down, 2 curve).

Tracing practice for the word "helo" (ice). The letters are dashed with numbered arrows indicating stroke order: 'h' (1 down, 2 curve), 'e' (1 down, 2 curve), 'l' (1 down, 2 curve), and 'o' (1 down, 2 curve).



Actividad: Traza la letra "k" y repasa las silabas.

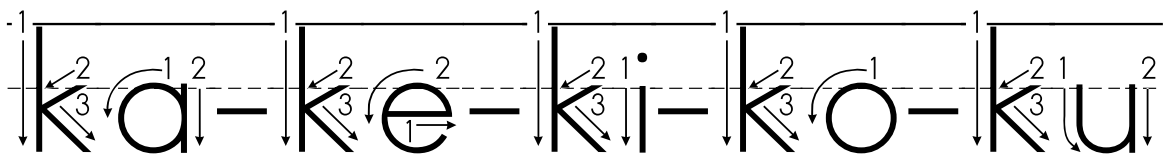
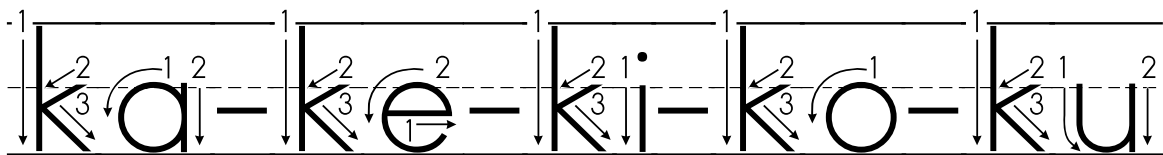
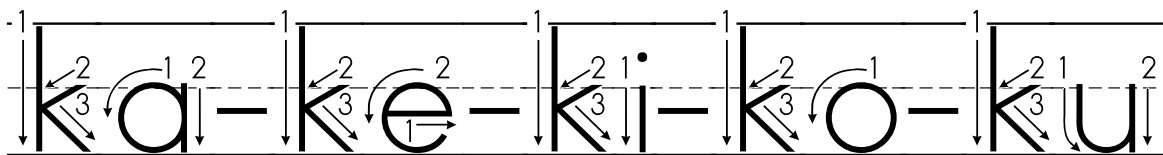
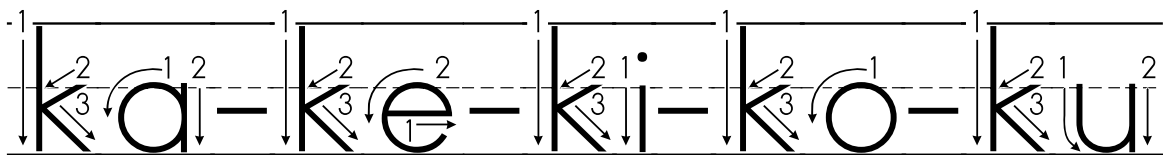
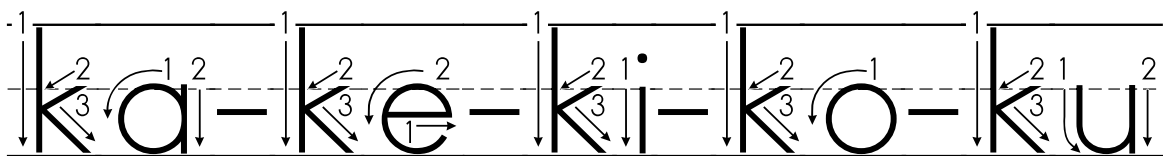
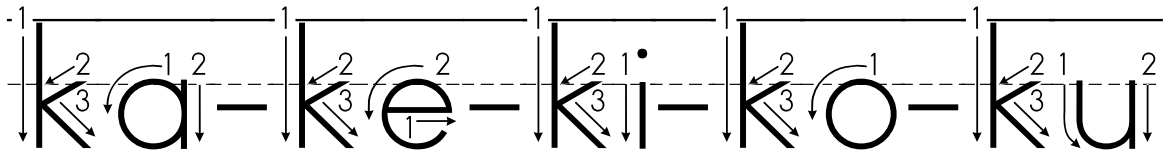
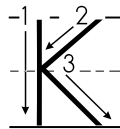
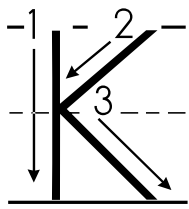

Actividad: Remarca las silabas que hacen falta y lee la palabra.

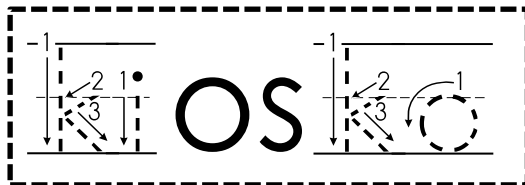
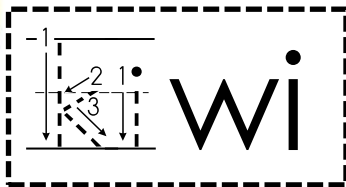
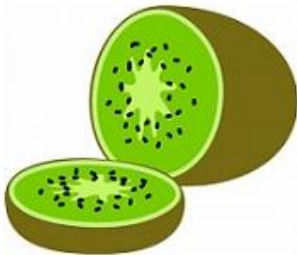
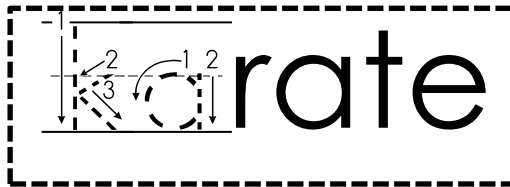
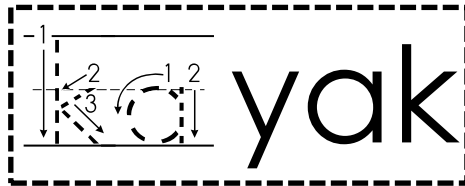
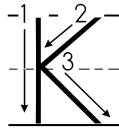
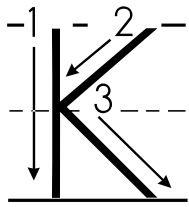

Actividad: Traza y remarca la letra "ñ". Repasa las sílabas.

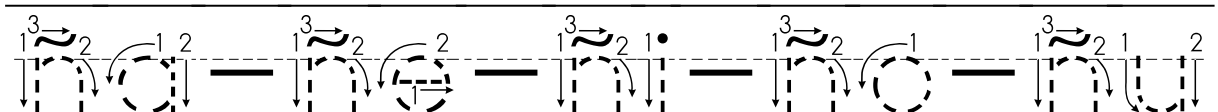
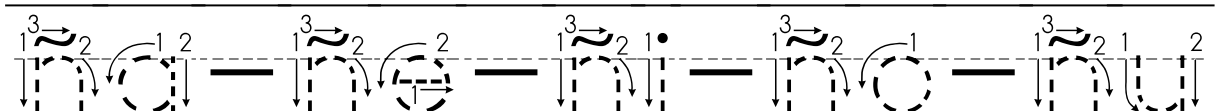
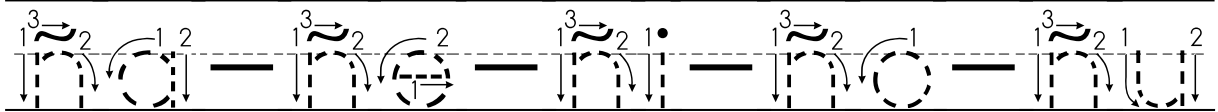
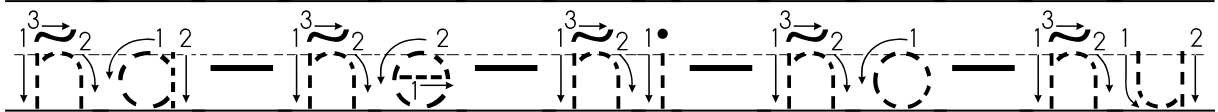
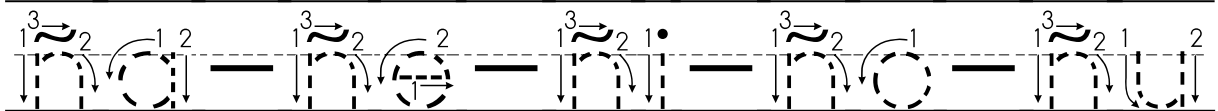
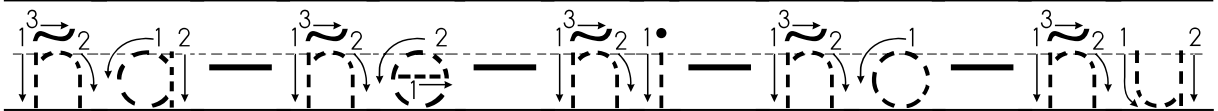
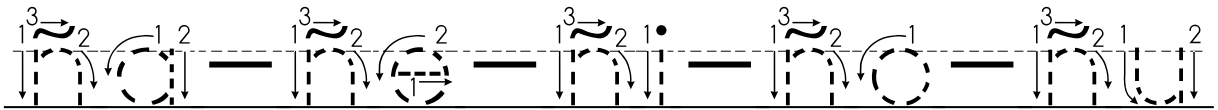
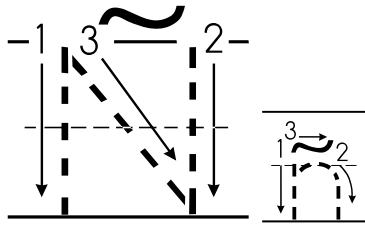

Actividad: En la tablet coloca correctamente los nombres de las imágenes, recuerda colocar en cada cuadro una letra.

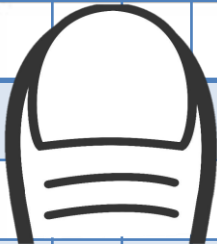
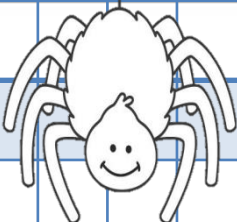
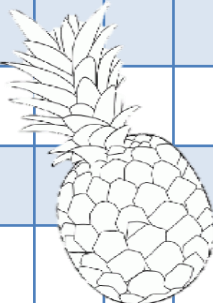
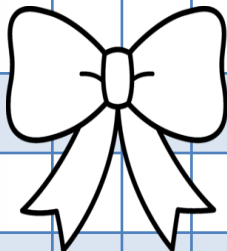
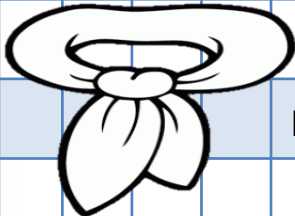
| | | |
|---|---|--|
|  | u |  |
|  | p | a |
|  | m | p |
|  | m | |



Actividad: Realiza el trazo de la letra "q" y repasa las sílabas.

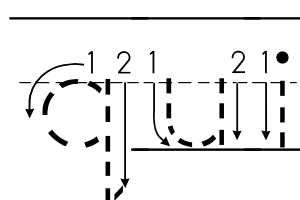
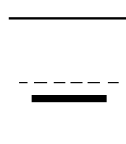
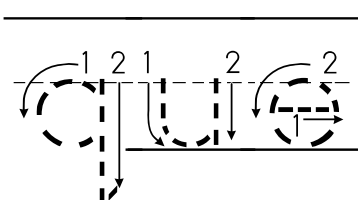
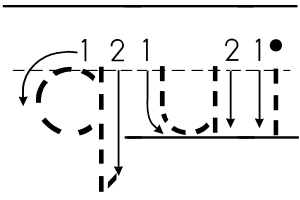
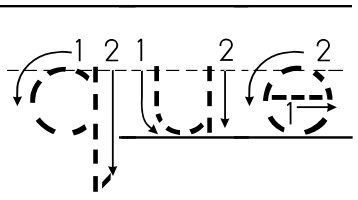
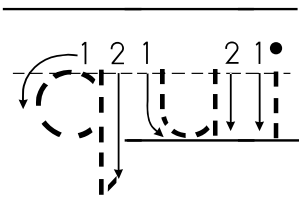
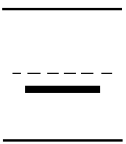
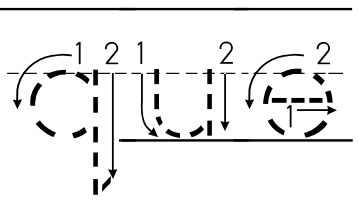
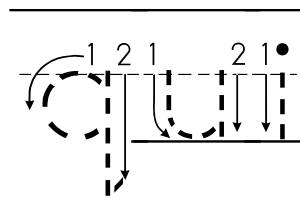
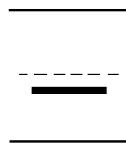
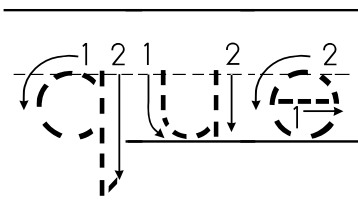
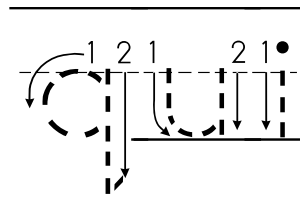
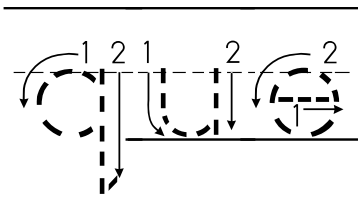
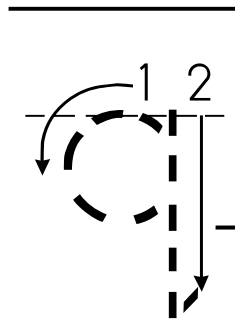
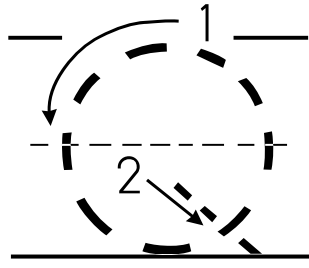

Actividad: En la tablet coloca correctamente los nombres de las imágenes, recuerda colocar en cada cuadro una letra.

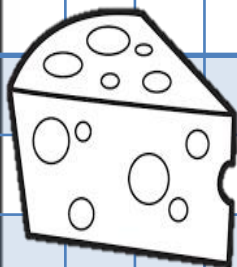

q

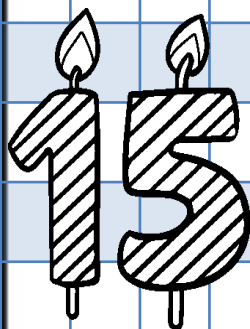

q

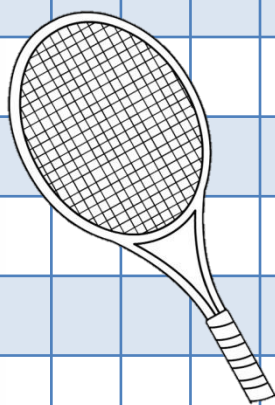

r



Actividad: Remarca y repasa las sílabas de la letra "w" .

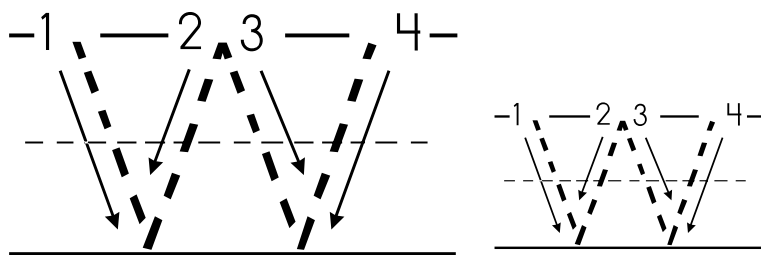

wa- wi- wo- wu- we

wa- wi- wo- wu- we

wa- wi- wo- wu- we

wa- wi- wo- wu- we

wa- wi- wo- wu- we

wa- wi- wo- wu- we



Actividad: Remarca y repasa las sílabas de la letra "X" .

xilófono

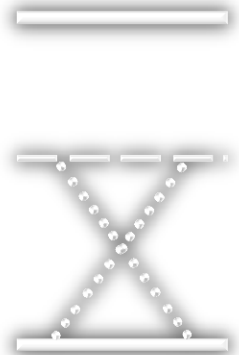
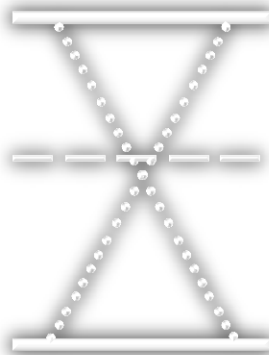
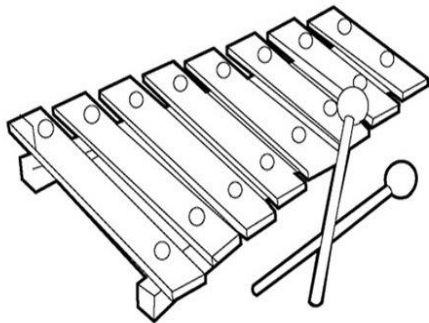

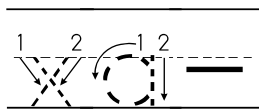
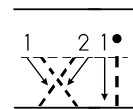
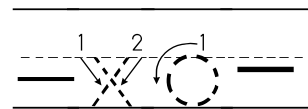
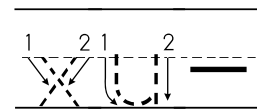
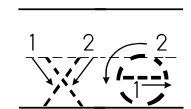
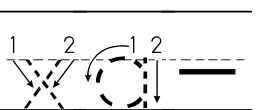
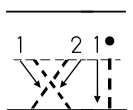
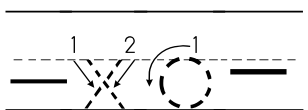
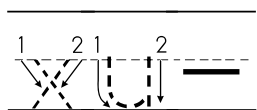
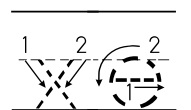
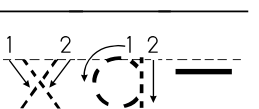
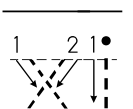
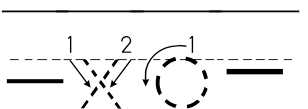
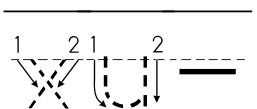
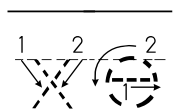
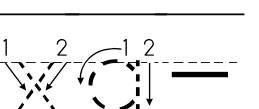
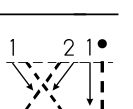
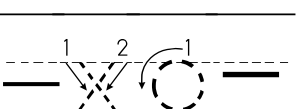
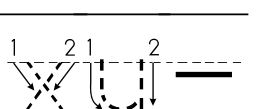
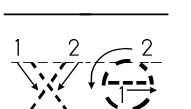
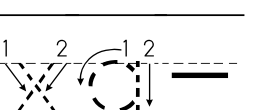
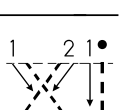
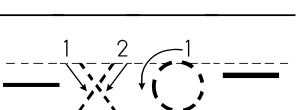
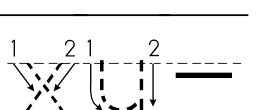
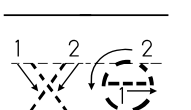
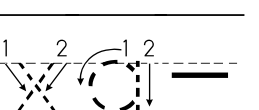
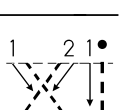
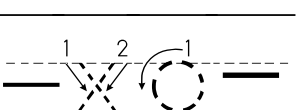
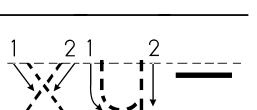
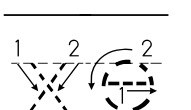
| | | | | |
|--|---|---|--|---|
|  |  |  |  |  |
|  |  |  |  |  |
|  |  |  |  |  |
|  |  |  |  |  |
|  |  |  |  |  |
|  |  |  |  |  |



Actividad: Remarca las siguientes palabras que tienen la sílaba de la familia de la "X". Colorea al finalizar.

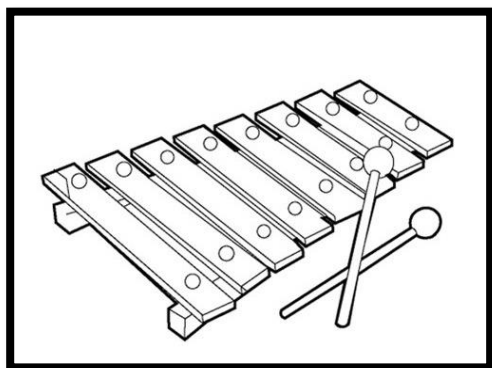

xilófono



taxi

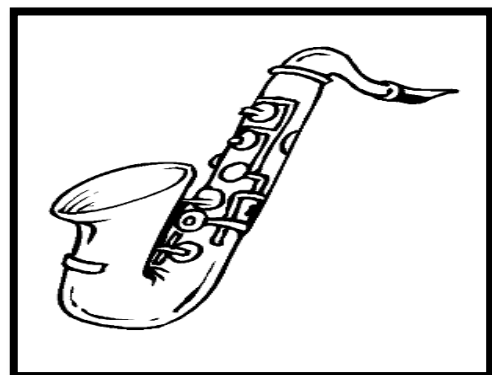

saxofón

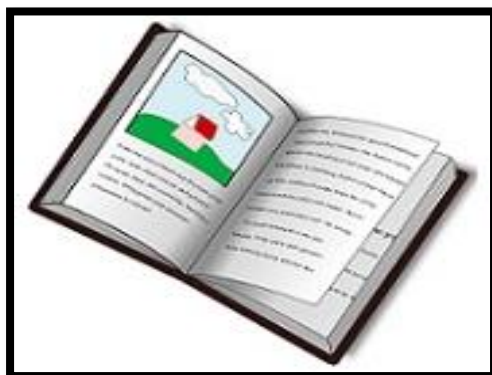

texto



boxeo



Actividad: Remarca y repasa las sílabas de la letra Y.

yoyo

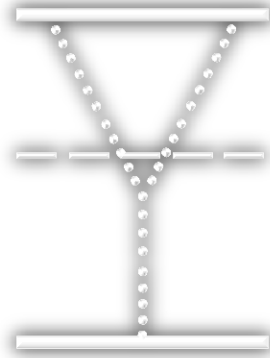
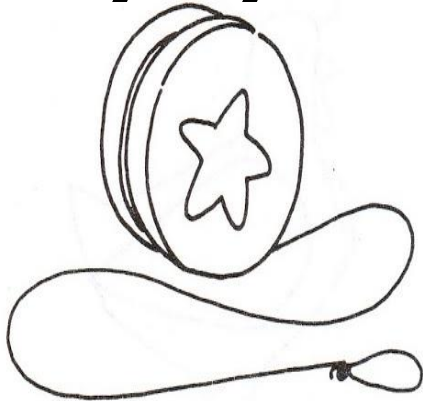

yo-ya-yi-yu-ye

yo-ya-yi-yu-ye

yo-ya-yi-yu-ye

yo-ya-yi-yu-ye



Actividad: Remarca las palabras y las sílabas. Colorea al finalizar.

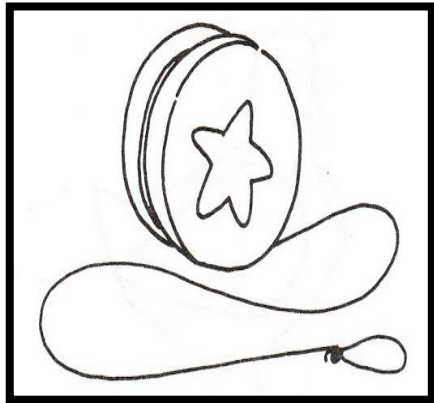

yoyo

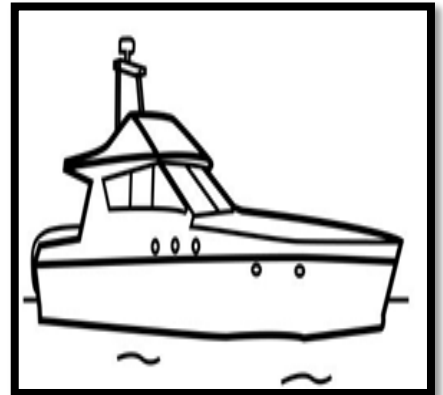

yate

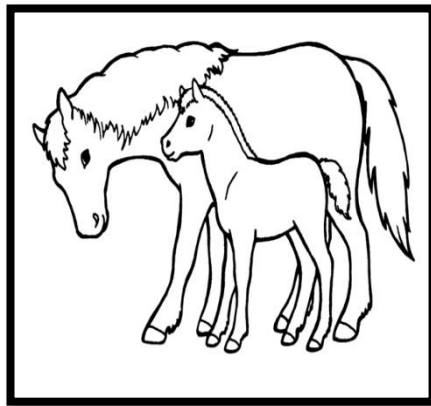

yegua

ya - ye - yi - yo - yu

ya - ye - yi - yo - yu



Actividad: Remarca y repasa las silabas.



za

ze

zi

zu

zo

za

ze

zi

zu

zo

za

ze

zi

zu

zo

za

ze

zi

zu

zo



zanahoria



zorrillo



Actividad: Agrega las sílabas que faltan. Apóyate en el cuadro de abajo. Colorea al finalizar.



__ pate

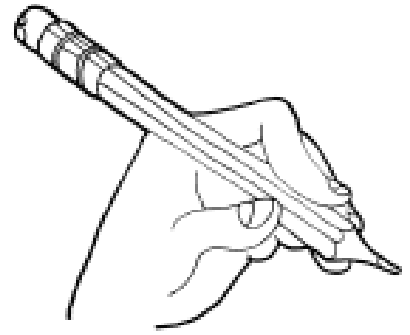

__ rdo



__ rro



__ rrido



__ pite

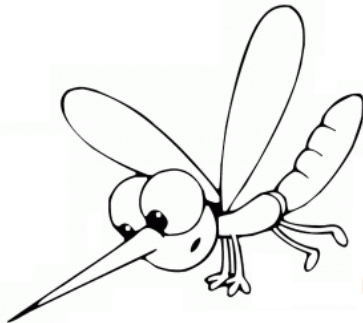
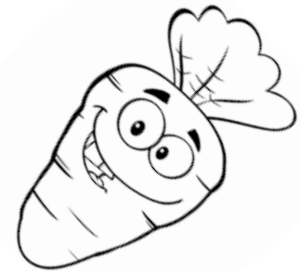
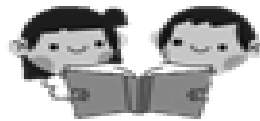

__ ncude

__ nahoria

| | | | |
|----|----|----|----|
| zo | za | za | zo |
| za | zo | zi | zu |

Actividad: Lee las oraciones y recorta la imagen que corresponda al enunciado.

1.- El gato juega con la pelota. →

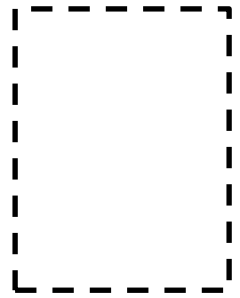
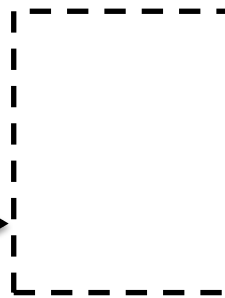

2.- El delfín vive en el mar. →

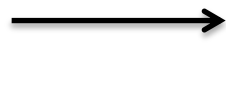

3.- Un elefante en el zoológico. →

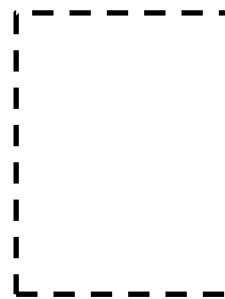

4.- Una jirafa en la selva. →



5.- El biberón del bebé. →

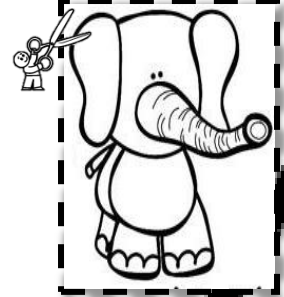
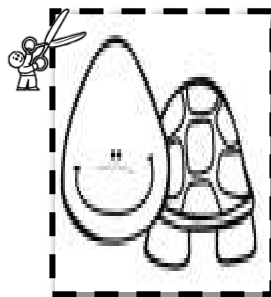
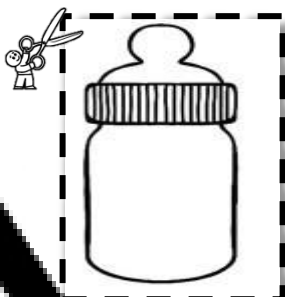
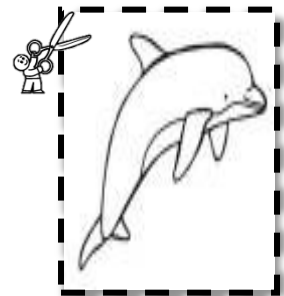
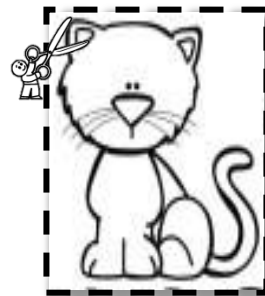
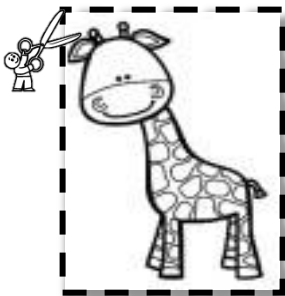
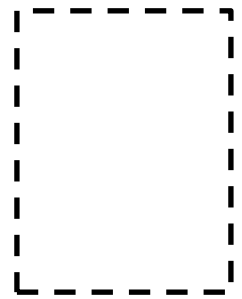

Actividad: Ordena las letras y arma la palabra, luego escríbela en la línea.

o p l a

l a p a

a c o f

b e n u

a c s a

r a p e

a c o f

a m o n

o m n o

a c r a



Actividad: Ordena las sílabas y arma la palabra escríbela en la línea.

raz

du

no

za

na

man

llo

ba

ca

ne

co

jo

o

le

par

do

ri

o

ca

na

re

si

na

bri

lla

som

ja

pa

ro

za

ce

re



Actividad: Ordena las sílabas y arma la palabra escríbela en la línea.

ton ra ci to

bo ar li to

za ca la ba

ci cle bi ta

es la cu e

le pa ta

la he do

tre lla es

co dri co lo

ti la gar ja

Actividad: Utiliza el alfabeto móvil para formar las palabras.

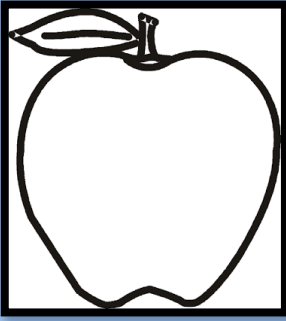

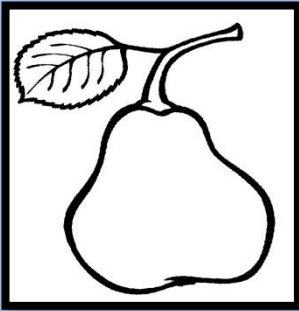

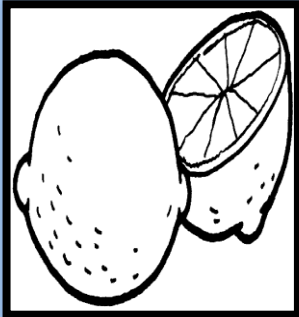

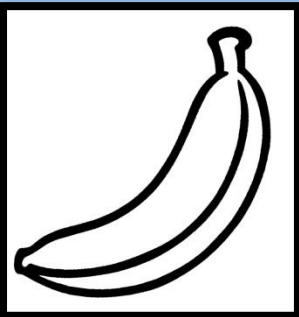

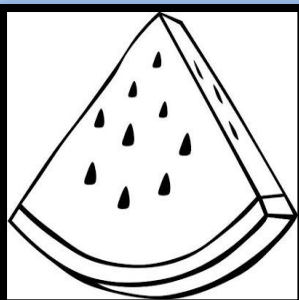



Actividad: Utiliza el alfabeto móvil para formar las palabras.

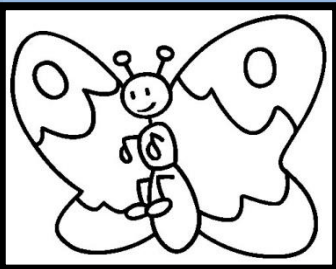

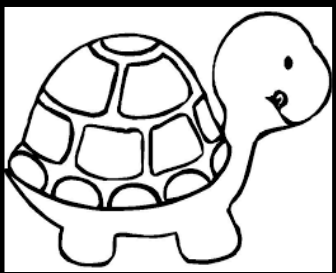

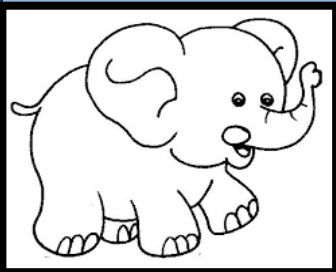



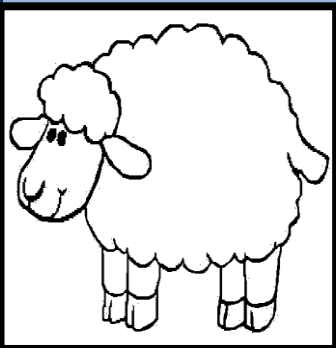



Actividad: Colorea el cuadro que tenga la palabra correcta.

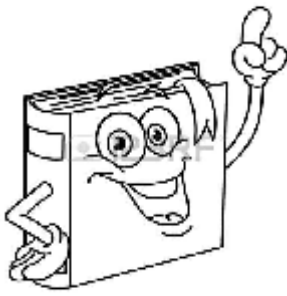

árbol

libro



cámara

lápiz



pelota

ala

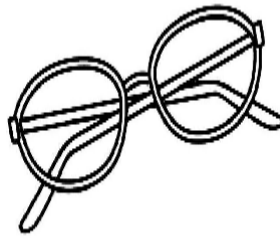

lente

rana

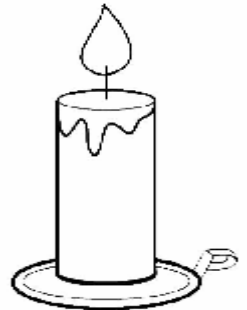

bola

vela



ojo

lupa



elote

fresa

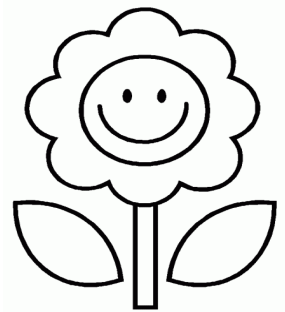

casa

flor



LECTURA COMPRESIVA

María todos los días se levanta muy temprano , y desayuna un rico pan acompañado con un café.

Cuando va de compras al mercado siempre compra frutas: una manzana, un melón, unas fresas, una pera y unas uvas y las pone en la mesa.



1.-Ponle un título a la lectura que acabas de leer.

2.- ¿En dónde compra frutas María?

3.- Dibuja las frutas que compra María.



LECTURA COMPRENSIVA

Jaime fue al zoológico.

Los papas de Jaime lo llevaron de paseo al zoológico, a la ciudad de Puebla. Jaime se sentía muy feliz por que veía a todo tipo de animales que no conocía: una gran ave que sus alas extendía un gran pavo real, otros como los monos que aullaban colgados de los arboles y hasta con el más grandote el elefante fue a parar

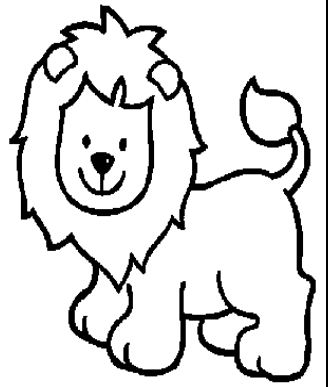

Jaime se asombro cuando vio a un gran león que rugía y comía sin parar. Por la tarde se comió una gran torta de jamón y bebió un poco de agua de jamaica, y es así como el paseo por fin dio final.

Contesta las preguntas:

1.- ¿Cómo se llama la lectura?

2.-¿A dónde llevaron a Jaime?

3.-¿ Qué animales vio Jaime en el zoológico?

4.-¿ Qué hizo en la tarde Jaime?



LECTURA COMPRENSIVA

Tito el mono.

Tito es un mono de color café y pequeño. A Tito le gusta trepar los arboles y le gusta comer mucho, pero muchos plátanos. También le gusta pasear por el bosque, oler las flores y recoger las nueces que se caen de los arboles.

Siempre va cargado con una cesta hecha con ramitas y cuando tiene mas de treinta nueces, elabora una deliciosa tarta de frutos secos y mermeladas de mango.

Como Tito es generoso, comparte el postre con sus amigos la ardilla, la tortuga y el conejo.

Contesta las preguntas:

1.-¿Cómo se llama el mono?

2.-¿Qué le gusta hacer a Tito?

3.-¿Qué elabora Tito con las nueces?

4.-¿Con que animales Tito comparte su postre?



LECTURA COMPRESIVA

Mateo lee.

Mateo al salir de la escuela lee un libro ese es su pasatiempo favorito. A el le gusta leer sobre los animales acuáticos.

Pero el animal que más le gusta es el delfín por que son muy lindos y cariñosos con las personas, el solo los ha visto mediante fotos y sueña algún día ir al acuario para poder ver uno y tocarlo.

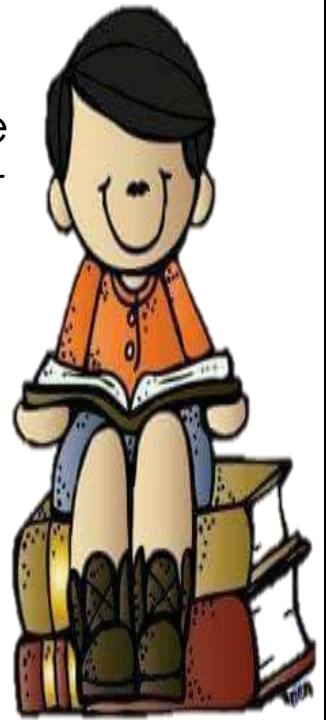

Contesta las preguntas:

1.- ¿Cómo se llama la lectura?

2.- ¿Cuál es el pasatiempo favorito de Mateo?

Dibuja el animal favorito de Mateo.

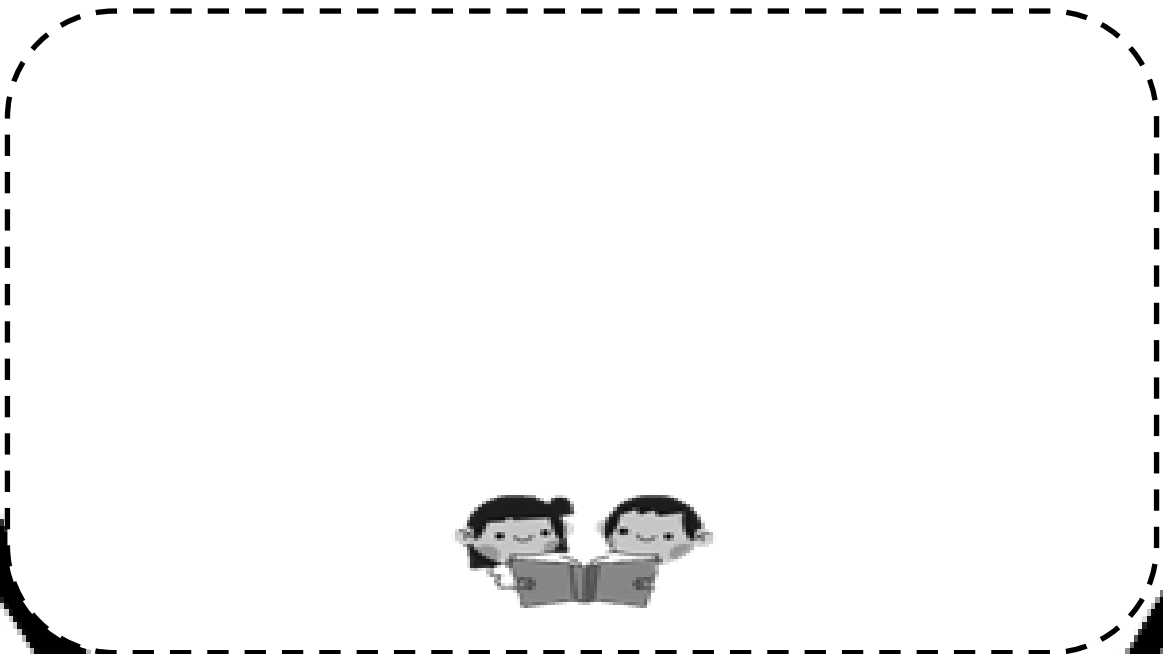

LECTURA COMPRESIVA



Carolina y Ana María

Carolina tiene 6 años y tiene el cabello muy largo que le cuelga casi hasta el piso y su piel es morena. Carolina tiene a una amiga con la que juega todos los días en el patio de su casa, y se llama Ana María ella también tiene 6 años van a la misma escuela, ella es del mismo tamaño que Carolina, pero ella tiene el cabello corto con trenzas y su piel es blanca.

Ellas juegan toda la tarde y después se ponen a estudiar un rato o hacer tareas que les dejó su maestra.

Por las noches se van a sus casas a cenar, bañarse y por último a dormir.

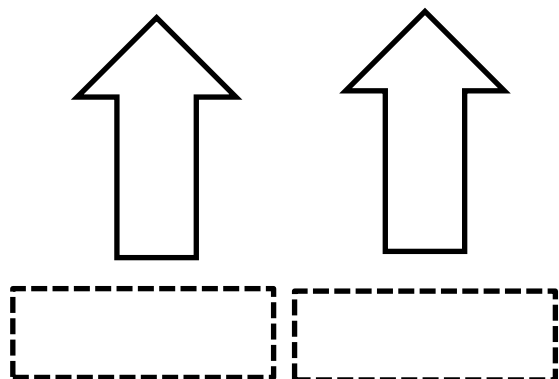

- 1.- Escribe quien es Carolina y Ana María.
- 2.- ¿Qué hacen las niñas por la **tarde**?

- 3.- ¿Qué hacen las niñas por las **noche**?

LECTURA COMPRENSIVA

Los amigos



Carlos y Martina van a la misma escuela, a ellos les gusta hacer muchos amigos y les gusta leer los libros así como respetar las reglas.

Ellos son amigos de Juan y de Gaby, a ellos les gusta ir a la biblioteca y leer muchos libros, cuando suena el timbre todos juegan en el patio de la escuela a la pelota.

Contesta



1.-¿Qué le gusta hacer a Carlos y Martina?

2.-¿Qué le gusta hacer a Juan y a Gaby?



Dibuja la escena donde juegan en el patio los amigos.



LECTURA COMPRENSIVA

El profesor Carlos

El profesor Carlos todos los días recibe a sus alumnos con una sonrisa y un abrazo, a ellos les gusta y algunas veces le traen una manzana de regalo.

Lili, Naney y Jaime son alumnos del profesor y les gusta estar conviviendo con el , también les gusta llegar temprano a clases y darle la sorpresa con una manzana.

A Jaime le gusta leer en clases y conocer muchas cosas, los niños ponen mucha atención y lo felicitan por saber leer.

Cuando es la hora de la salida, se despiden de los compañeros y de su profesor Carlos con un fuerte abrazo.



Contesta:

1.-¿Cómo se llama el profesor? _____

2.-¿Cómo se llaman los alumnos? _____

3.-¿Cuál es el regalo que le llevan los alumnos a su profesor? _____

4.-¿Qué le gusta hacer a Jaime en clases? _____

LECTURA COMPRENSIVA

El zoológico

En mayo Liliana y su familia fueron al zoológico de Puebla, vieron muchos animales, entre ellos jirafas, leones, hipopótamos y rinocerontes. Todos estaban muy emocionados y tomaron varias fotos. El animal que más le gusto a Liliana fue la jirafa y cuando regreso a su casa les contó a sus amigos lo divertido que había sido visitar el zoológico.

Contesta:

1.- ¿Cuándo fueron al zoológico Liliana y su familia?

2.-¿En que ciudad esta el zoológico?

3.-¿cuál fue el animal que más le gusto a Liliana?

4.-¿cómo se sintieron al visitar el zoológico?

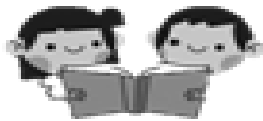

Dibuja una escena cuando Lilia conoce a la jirafa.



LECTURA COMPRESIVA

Dumbo el elefante

Dumbo era un elefantito muy gracioso y juguetón. Su trompa era de un color gris-perla; la más bonita trompa que jamás se ha visto.

Pero ¡ay! Sus orejas eran tan grandes que le llegaban casi a las rodillas.

Por eso los otros elefantes del circo se burlaban. Las burlas de sus compañeros le ponían triste.

Entonces una ratita amiga le animaba:

-No llores; con esas orejas tú puedes volar...

-¿Por qué no? -pieron las golondrinas.

Dumbo se subió al trapecio del circo, extendió las orejas y se soltó.

¡Qué maravilla! ¡Dumbo volaba!

¡Cómo le envidiaban ahora sus grandes orejas los demás elefantes!.

Dibuja a Dumbo

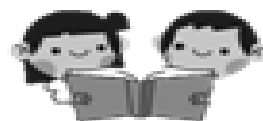

LECTURA COMPRESIVA

Un paseo en el parque.

La familia de Katy fue a un paseo el domingo por la tarde al parque. Katy jugaba con su pelota nueva cuando de repente vio un cotorro arriba de un árbol. El cotorro era grande y con alas verdes como las hojas de los arboles. Pensó jugar con el y le lanzó la pelota, pero solo vio como caía al suelo. Tan distraída estaba Katy que se le paso el tiempo y mejor decidió volver con su familia.



Colorea a los personajes de la lectura anterior.



LECTURA COMPRENSIVA

Los hermanos: Gustavo y Gaby.

Gustavo y Gaby son hermanos van a la misma escuela pero en diferente grado escolar.

Gustavo va en tercer grado y Gaby en primero.

A Gustavo le gusta jugar futbol y a su hermana con las muñecas, cuando salen de la escuela se van juntos y esperan con ansias volver a la escuela.

1.- Recorta las letras y construye los nombres de los personajes.

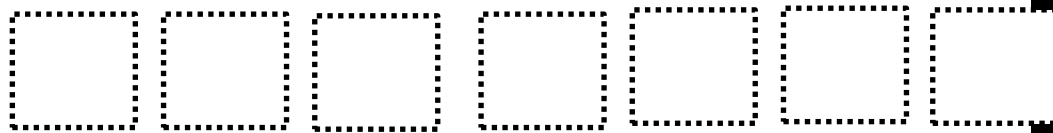
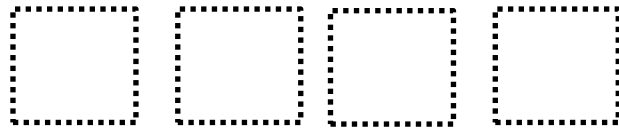

a

b

g

y



u

v

o

s

t

G

a

ALFABETO MÓVIL

a b c d e f g

h i j k l m n

ñ o p q r s t

u v w x y z



ALFABETO MÓVIL

A B C D E F G

H I J K L M N

Ñ O P Q R S T

U V W X Y Z

