

Actividades de Conciencia Fonológica

El camino a la lectoescritura



Kínder

Queridos Niños de Lo Prado:

El presente material consiste en una recopilación de actividades de diversos libros y aportes individuales de distintos profesionales, realizado por las fonoaudiólogas del Proyecto de Integración Escolar de Lo Prado.

El objetivo es estimular la conciencia silábica y fonémica de los niños de Pre-Kínder, Kínder y Primero Básico del PIE de Lo Prado.

Esperamos que este material elaborado con amor y dedicación sea un aporte en el proceso educativo y entregue herramientas para el aprendizaje de la lectoescritura.



Sus Fonoaudiólogas



Claudia Arenas Ampuero
Catalina Hernández Riveros
Magdalena Muñoz Montes
Daniela Rojas Contreras
Michelle Scaramelli Soiza
Loreto Tobar Villegas

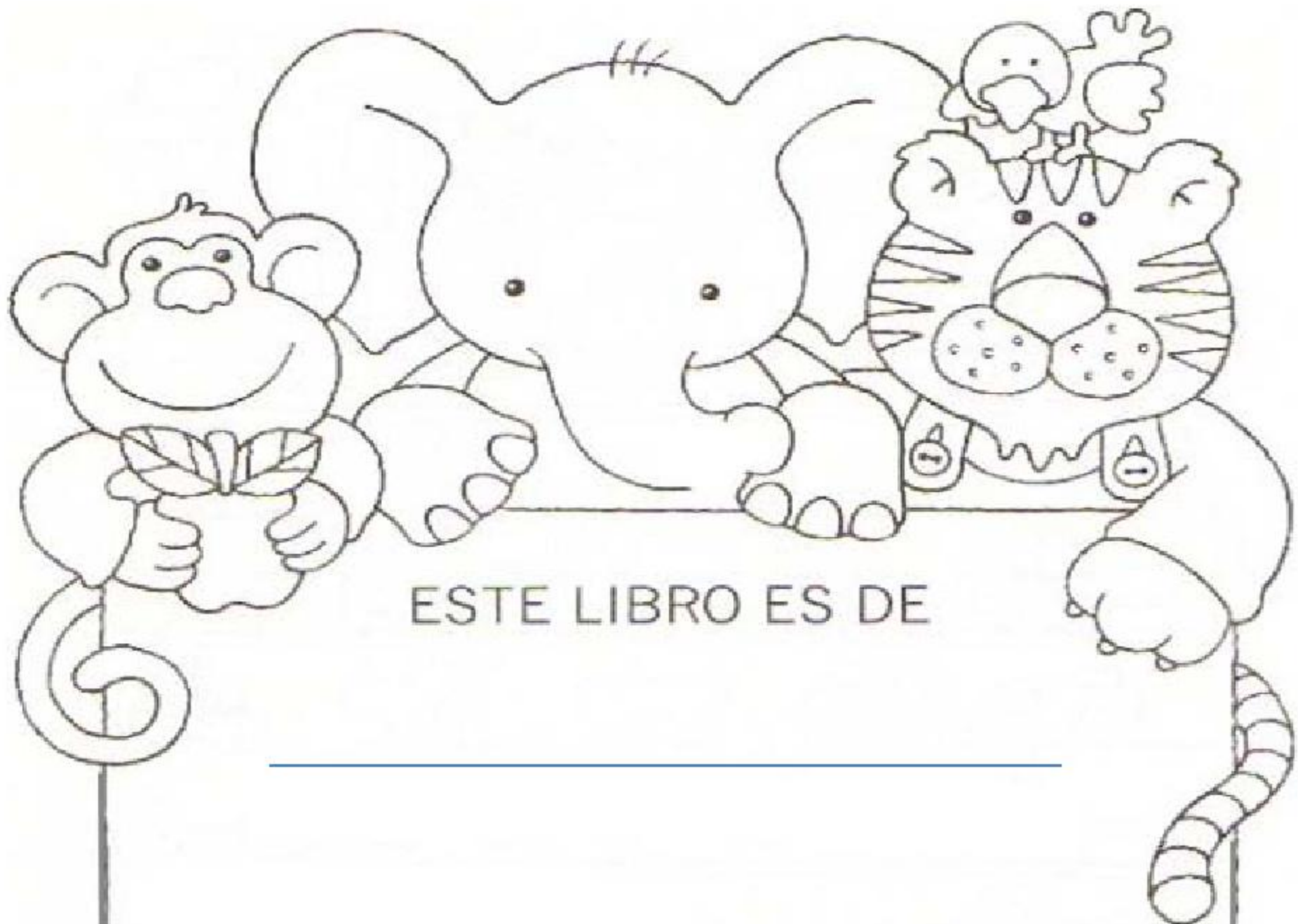

ESTE LIBRO ES DE



Dibújate en este espacio

Cuenta el número de sílabas de cada dibujo y pinta cada círculo.

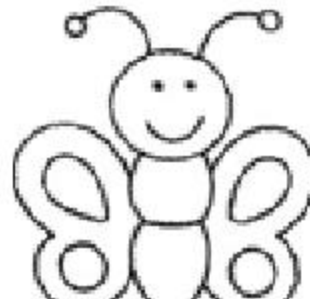
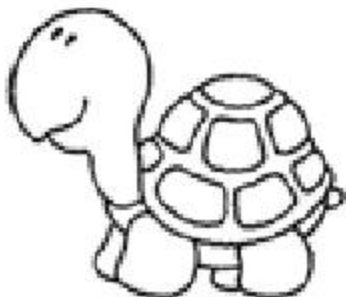
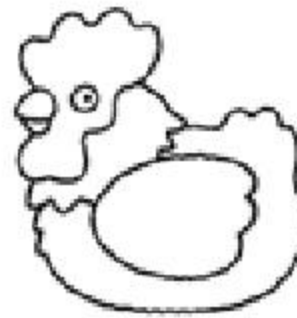
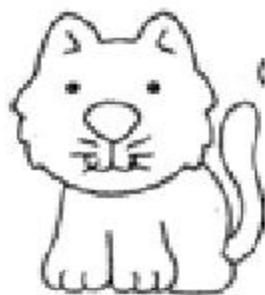
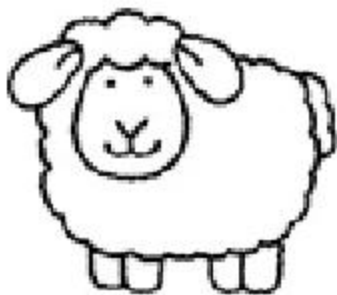
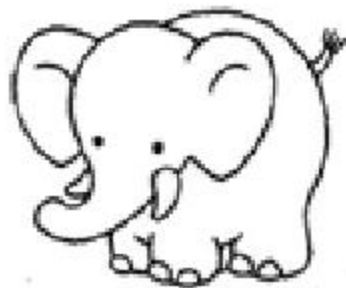
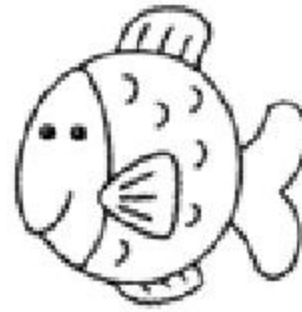
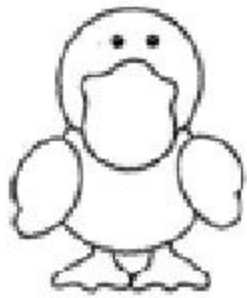
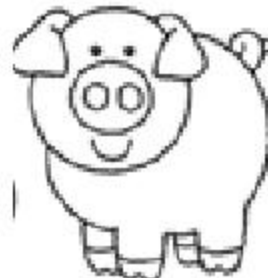

Claudia Arenas Ampuero Fonoaudióloga

Actividad complementaria: ¿A qué categoría semántica pertenecen las imágenes?, busca otros elementos que pertenezcan a esta categoría y describan cada elemento.

Cuenta el número de sílabas de cada dibujo y pinta según corresponda.

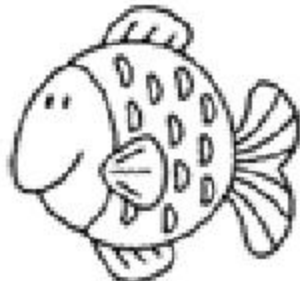
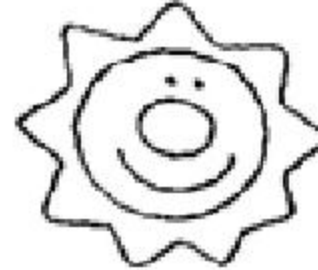
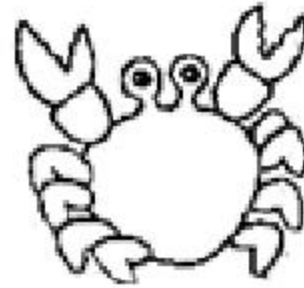

Claudia Arenas Ampuero Fonoaudióloga

Actividad complementaria: ¿A qué categoría semántica pertenecen las imágenes?, encuentra el elemento intruso. Busca otros elementos que pertenezcan a esta categoría y describan cada elemento.

Dibuja tantas cruces como sílabas tenga el dibujo.

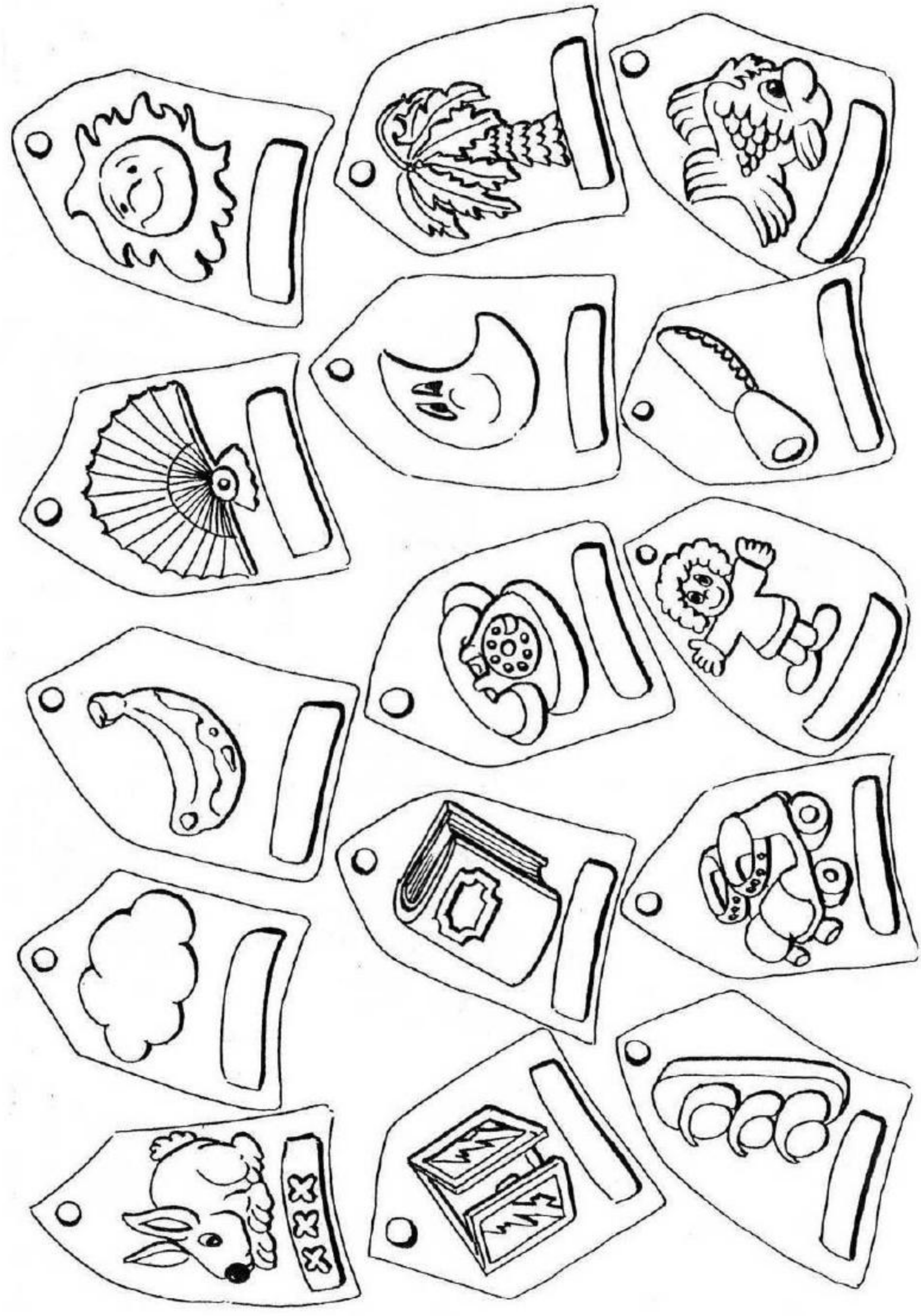



Encierra en un círculo los intrusos (aquellos que tienen distinta cantidad de sílabas).

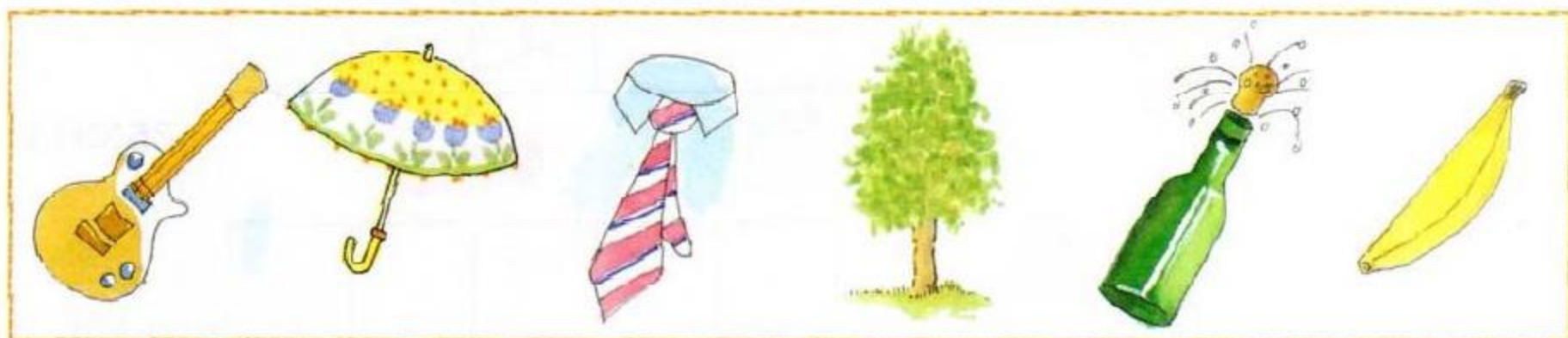



Marca los elementos que tengan la misma cantidad de sílabas que el modelo.

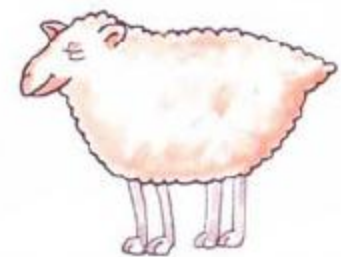
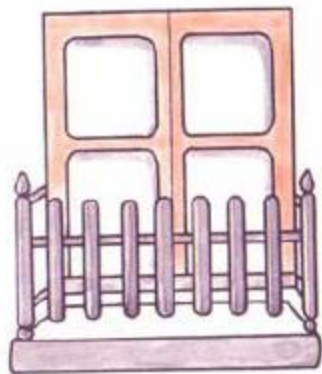
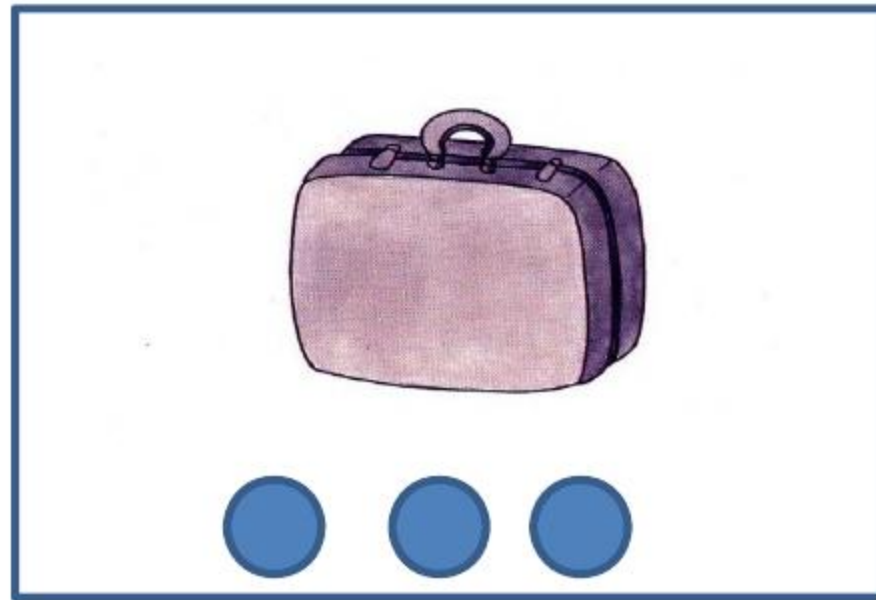



Marca los elementos que tengan la misma cantidad de sílabas que el modelo.

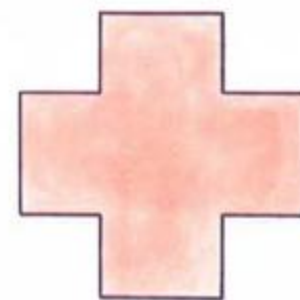
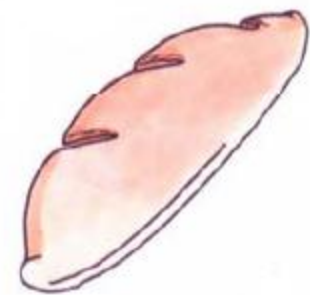
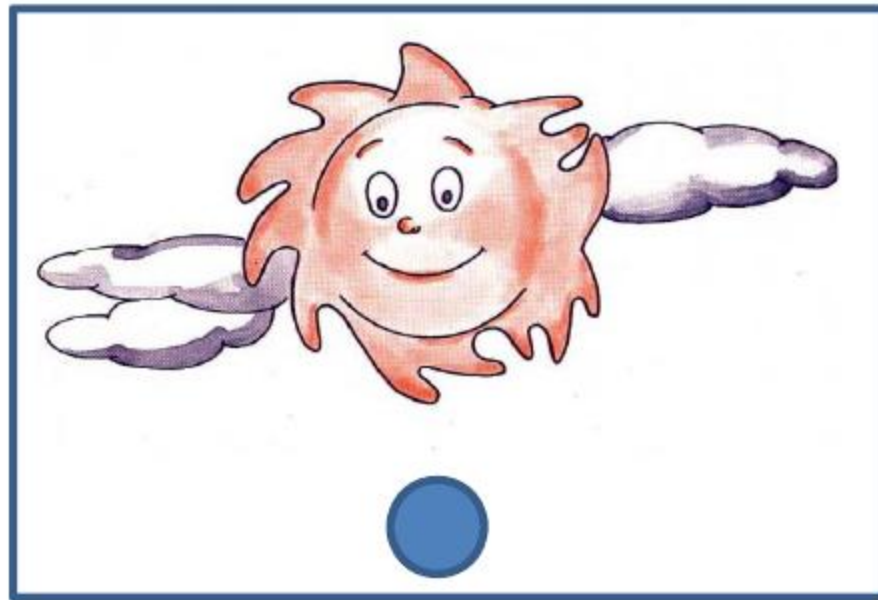

Cuenta las sílabas de los tres dibujos. Pinta rojo (1 sílaba) azul (2 sílabas) y verde (3 sílabas).

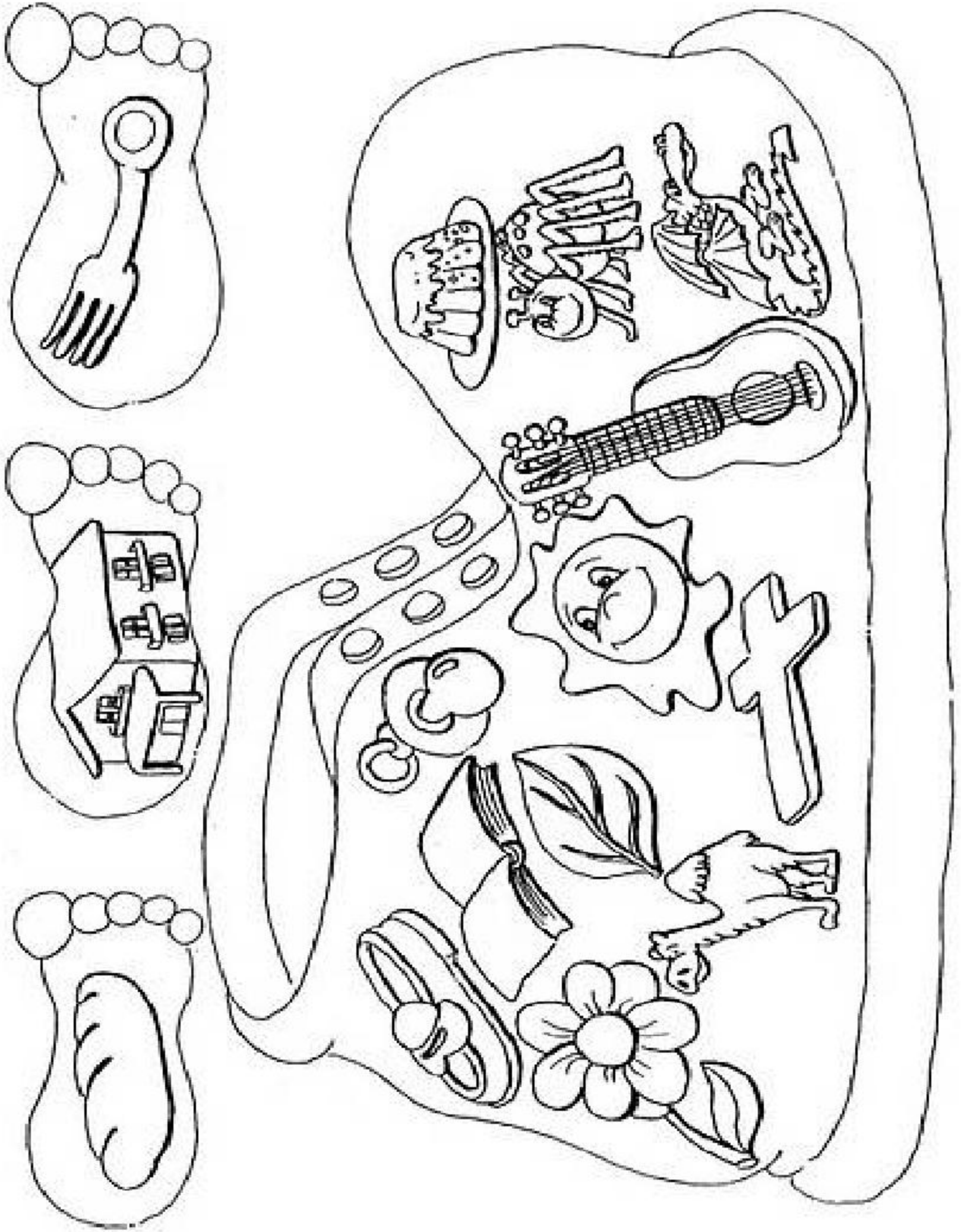

Cuenta las sílabas de los dibujos y pinta según corresponda:

Amarillo



Naranja



Verde





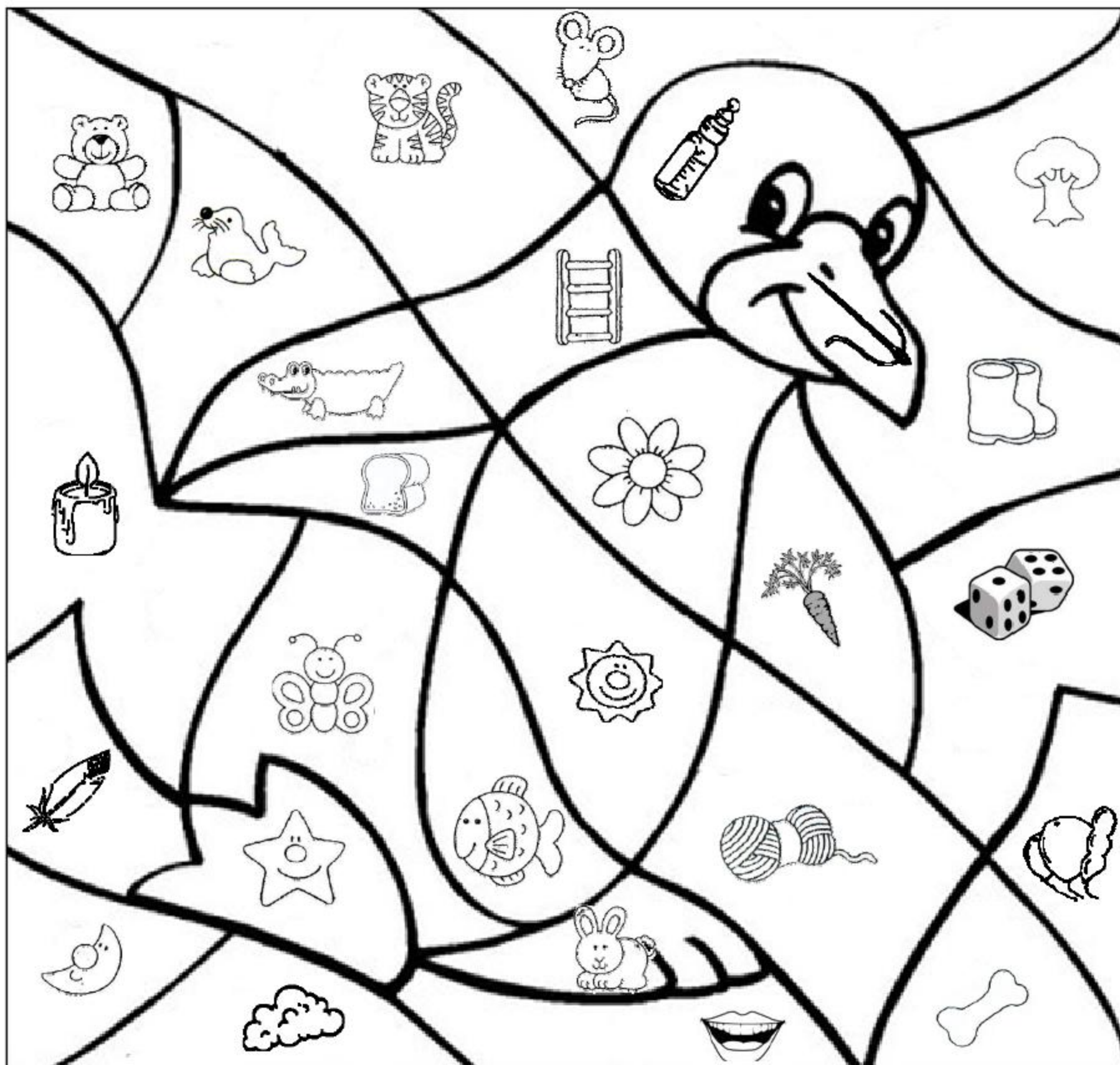





Azul





Recorta las imágenes de la página 87. Luego pégalas en los espacios según el número de sílabas de cada imagen (1, 2, 3 ó 4 sílabas).

Claudia Arenas Ampuero Fonoaudióloga



Juanito hizo mal su tarea, debes corregirla pintando las que están buenas y ponerle una cruz a las que están malas.

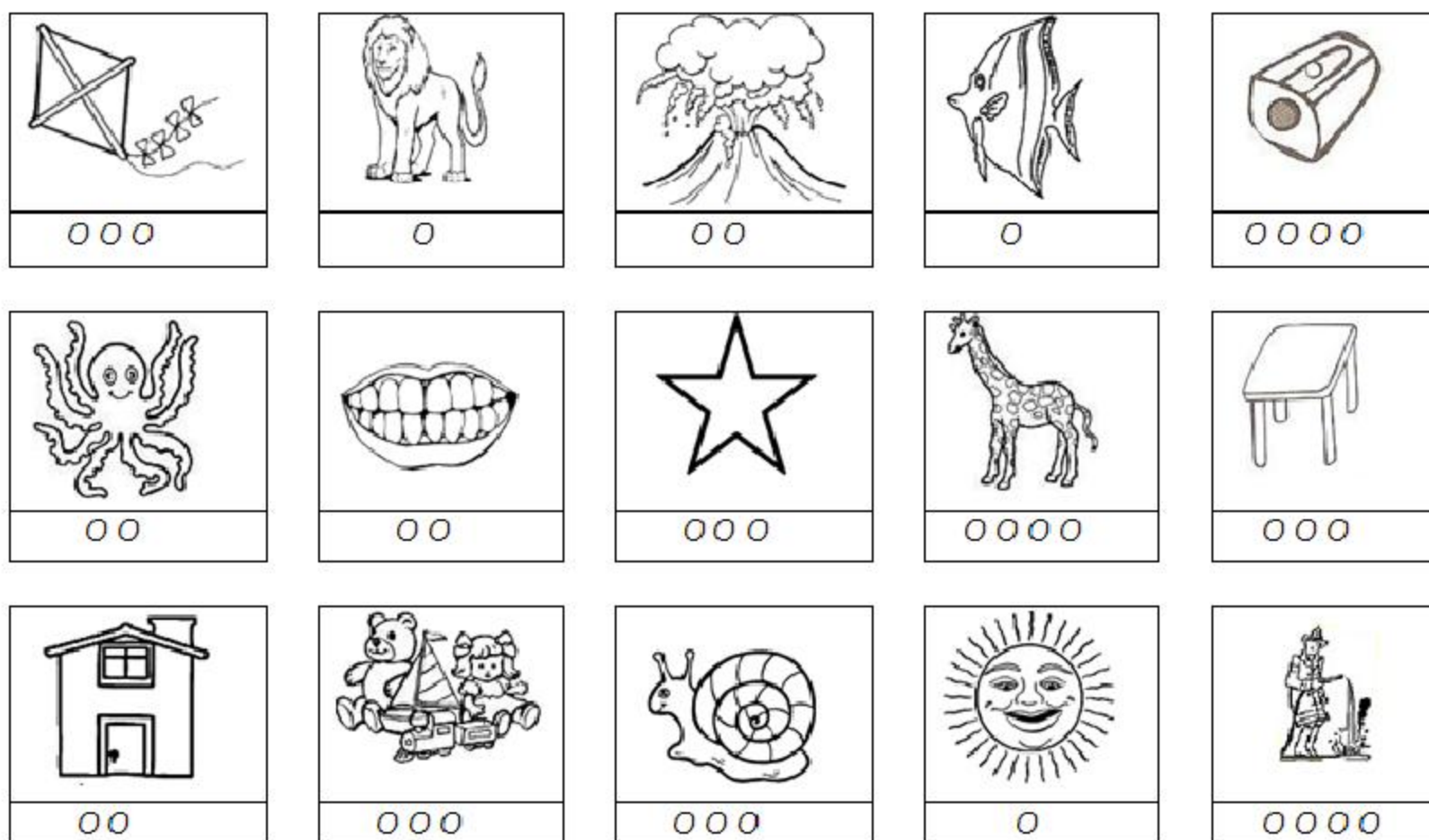

Ingrid Loaiza. Profesora Especialista en Lenguaje

Pedro hizo mal su tarea, debes corregirla pintando las que están buenas y ponerle una cruz a las que están malas.

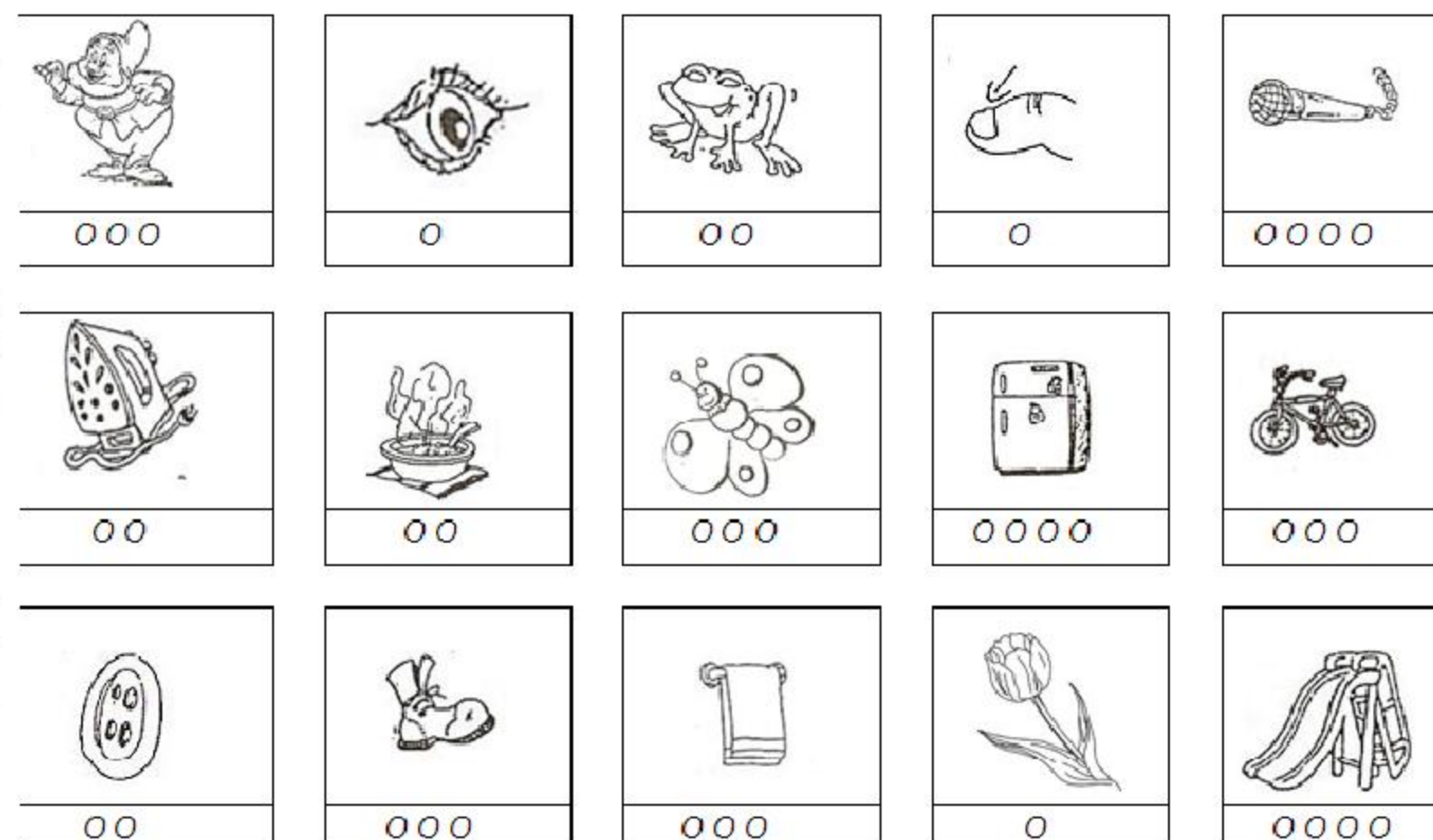

Ingrid Loaiza. Profesora Especialista en Lenguaje

Dibuja un elemento de igual cantidad de sílabas que el modelo.

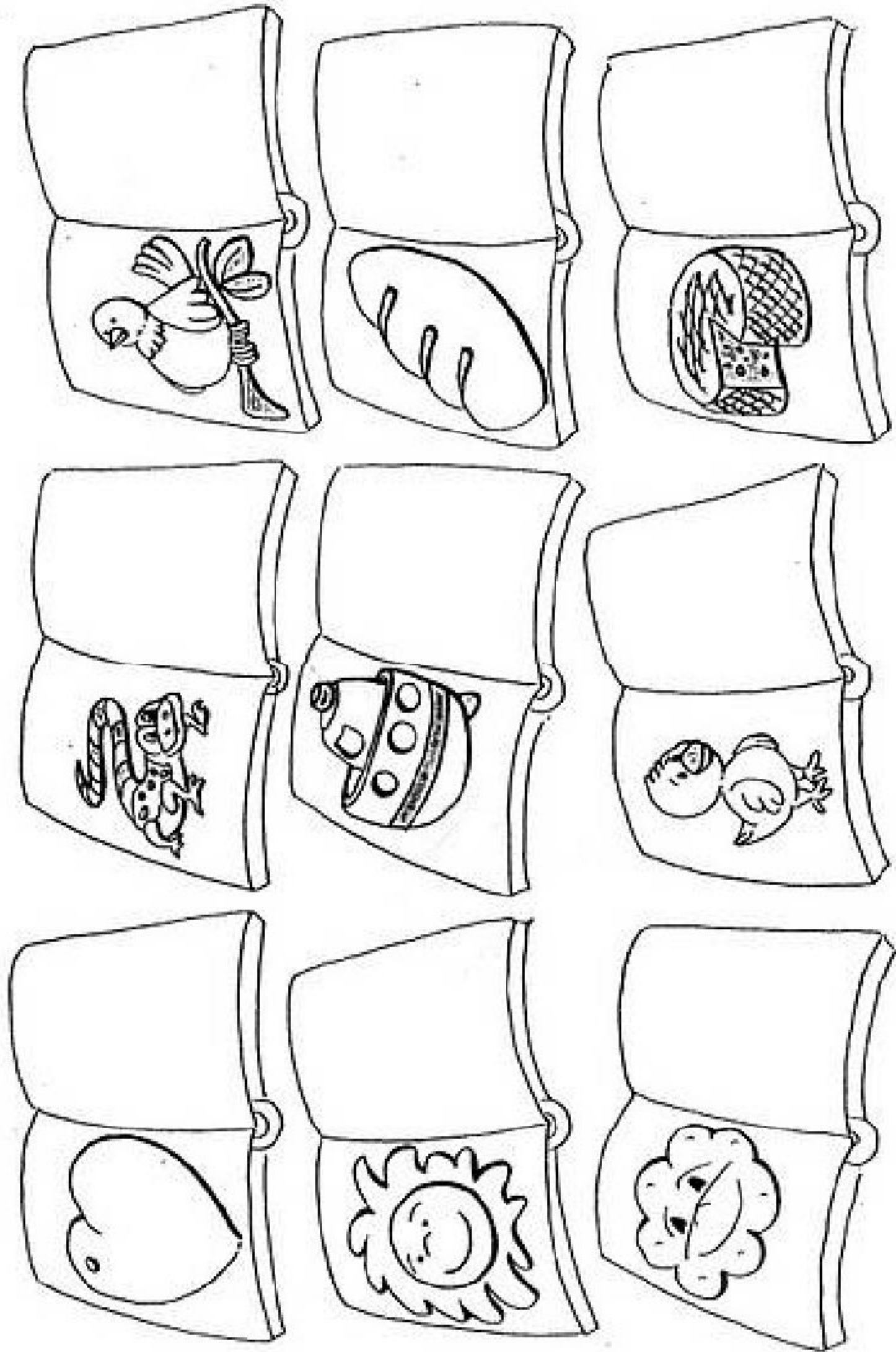

Pintar el número que corresponda a las sílabas del dibujo.



1
2
3
4
5

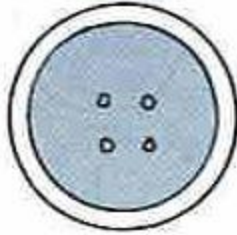

1
2
3
4
5



1
2
3
4
5



1
2
3
4
5

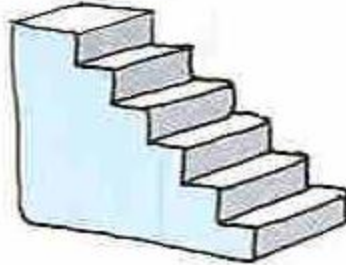

1
2
3
4
5

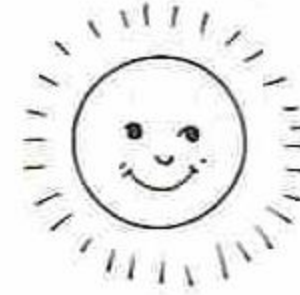

1
2
3
4
5

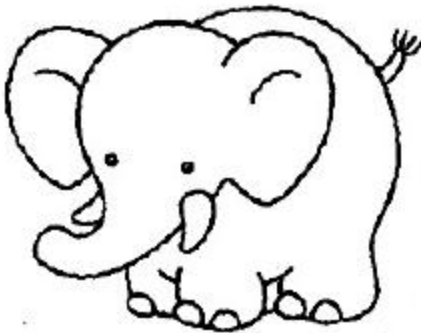

1
2
3
4
5



1
2
3
4
5

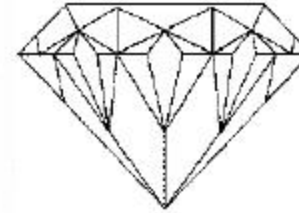

1
2
3
4
5



1
2
3
4
5



1
2
3
4
5

Ingrid Loaiza. Profesora Especialista en Lenguaje

Di en voz alta el nombre de cada dibujo. En cada fila marca el más corto.

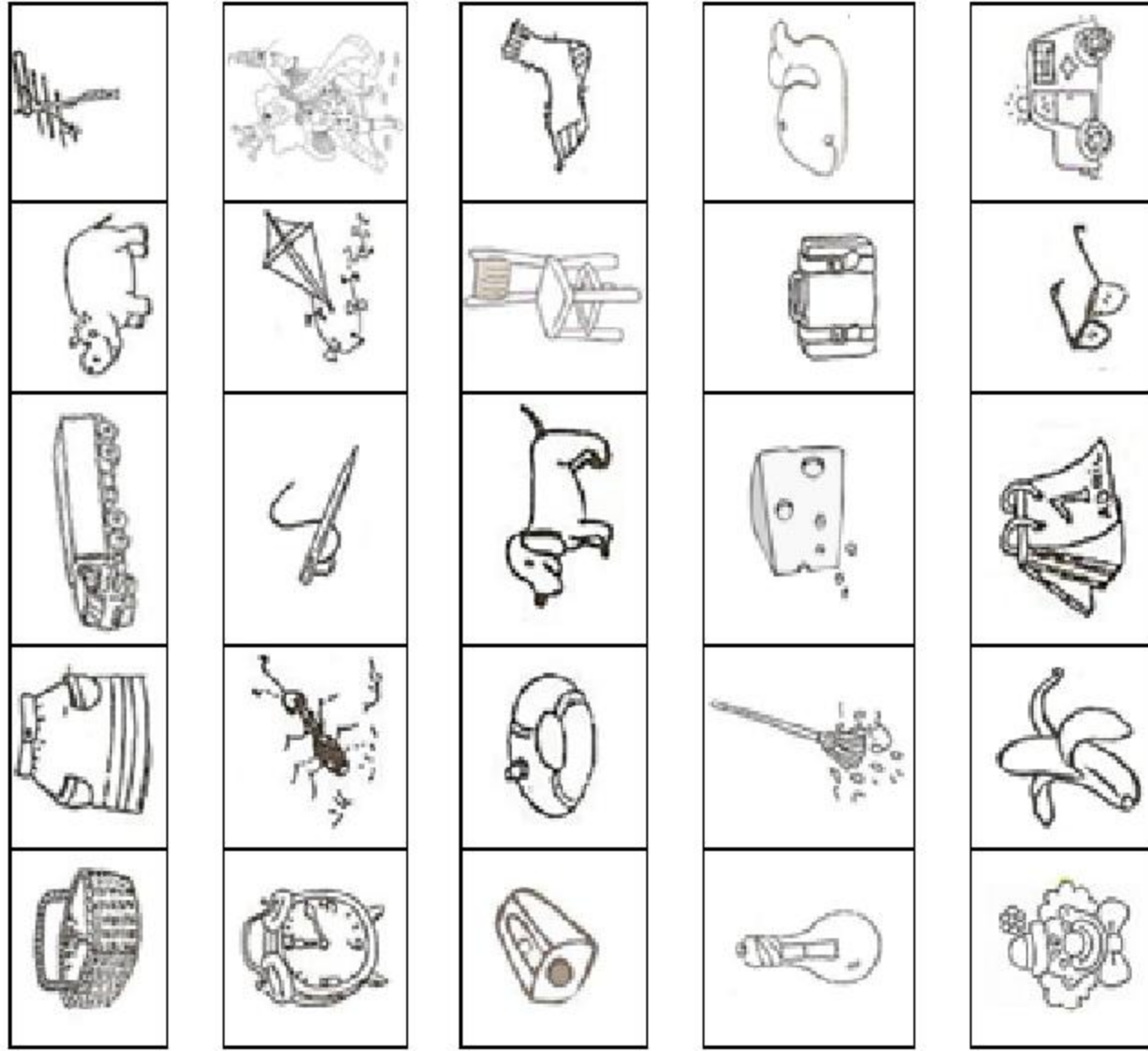

Di en voz alta el nombre de cada dibujo. En cada fila marca el más largo.

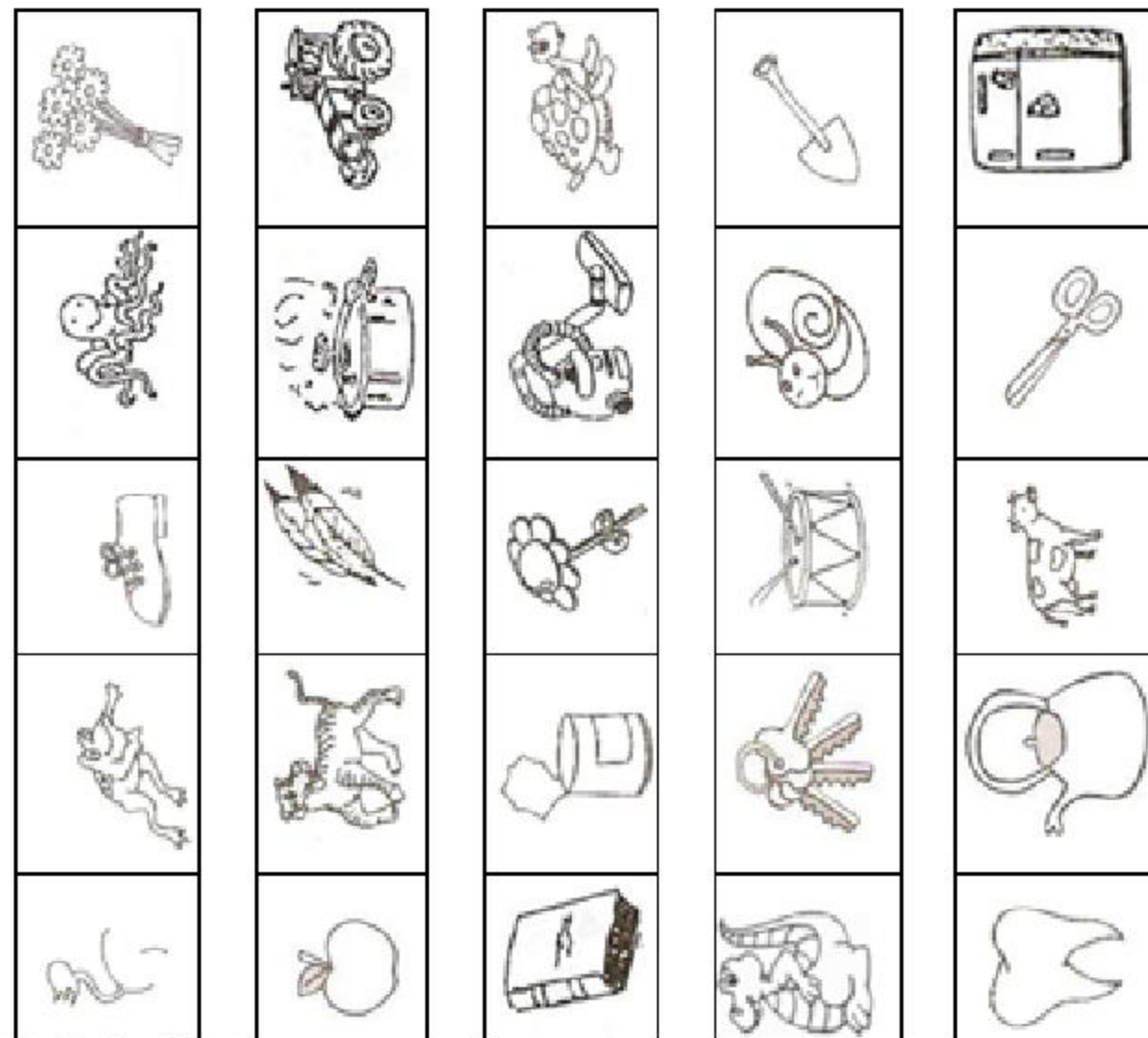

← Pinta los elementos que comienzan con la sílaba /ma/.



↑ Pinta los elementos que comienzan con la sílaba /pa/.

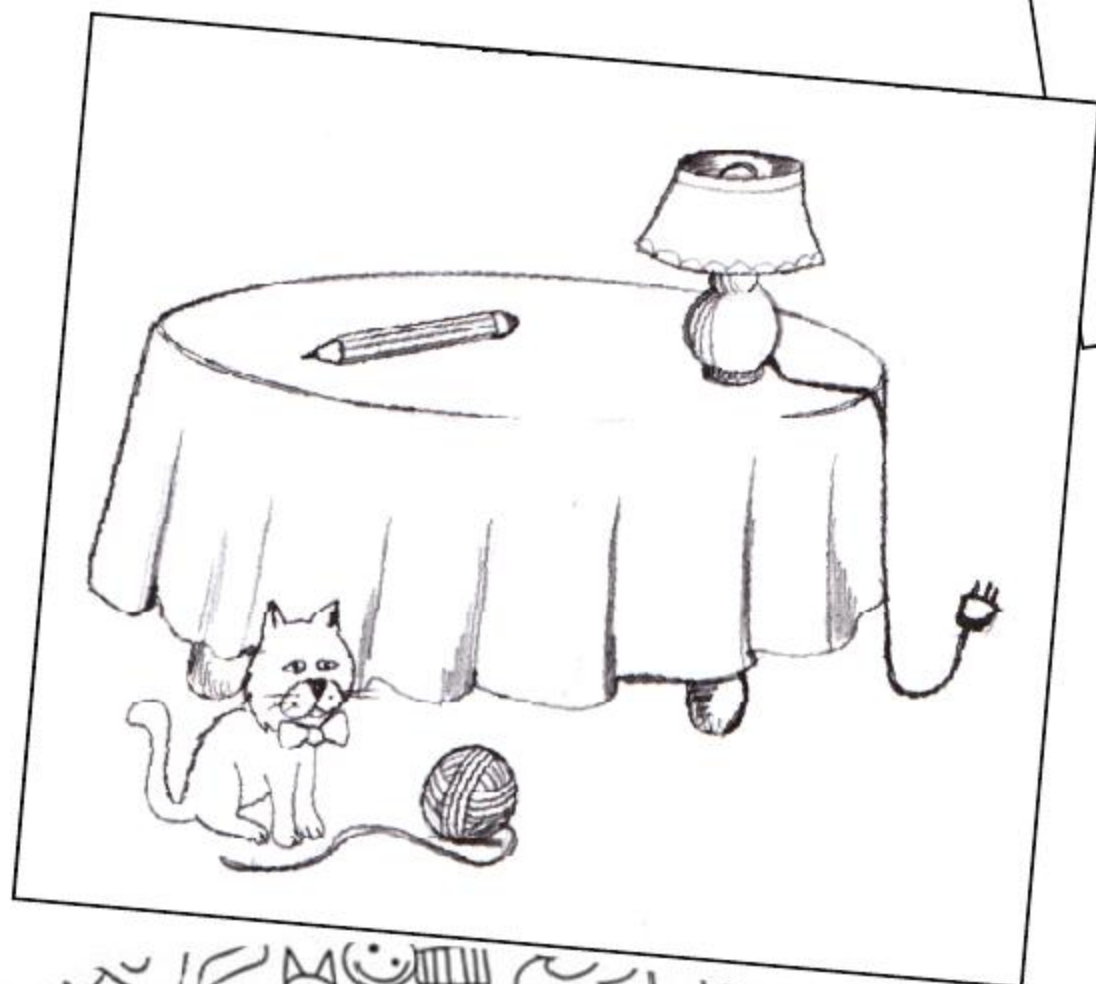

← Pinta los elementos que comienzan con la sílaba /la/.

Une los dibujos cuyo nombre comienzan por la misma sílaba.

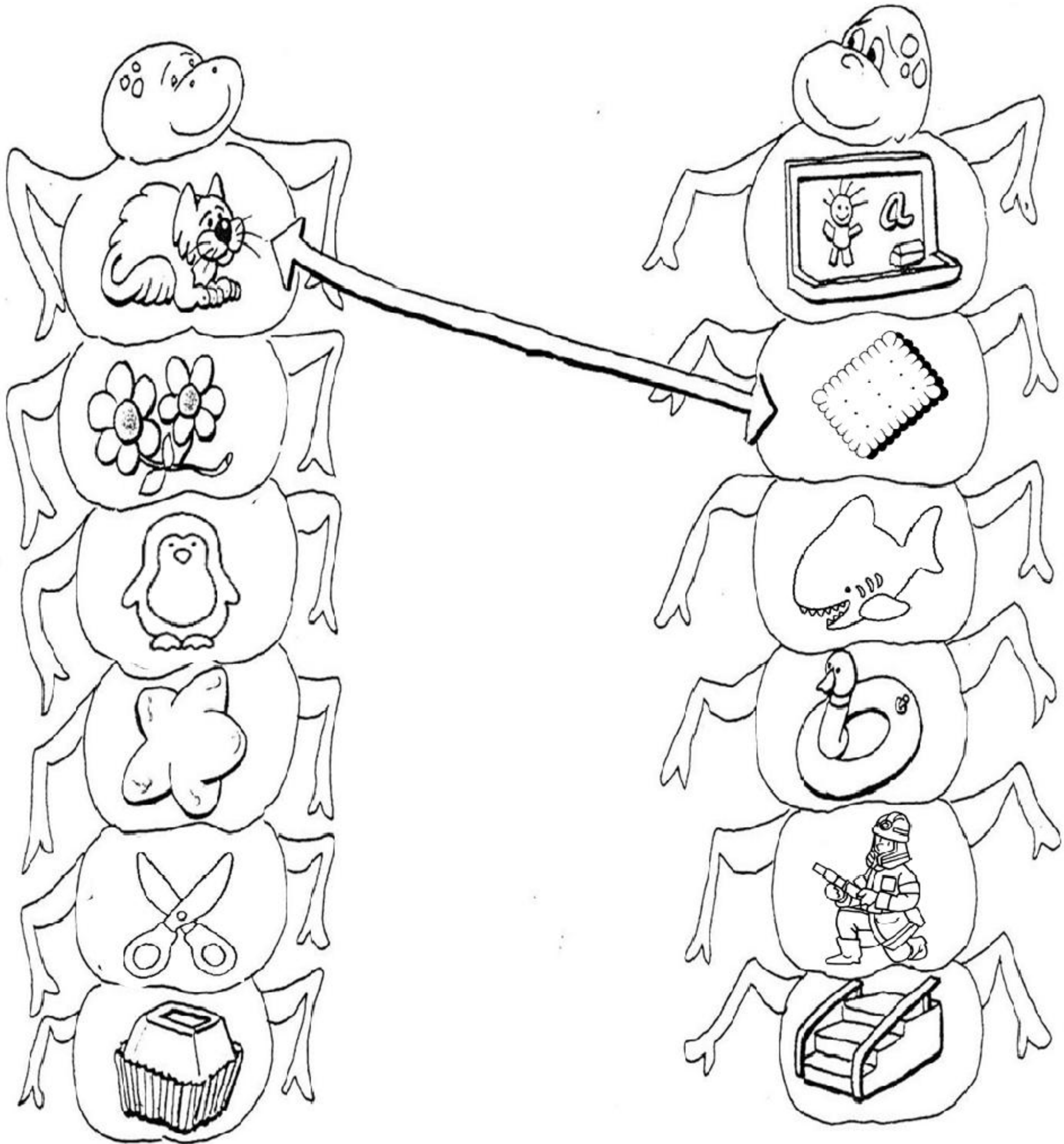

Estímulos: gato, flores, pingüino, estrella, tijera, bombón, pizarra, galleta, tiburón, flotador, bombero, escalera.

Recorta los dibujos de la página 88 y pégalos donde corresponda.

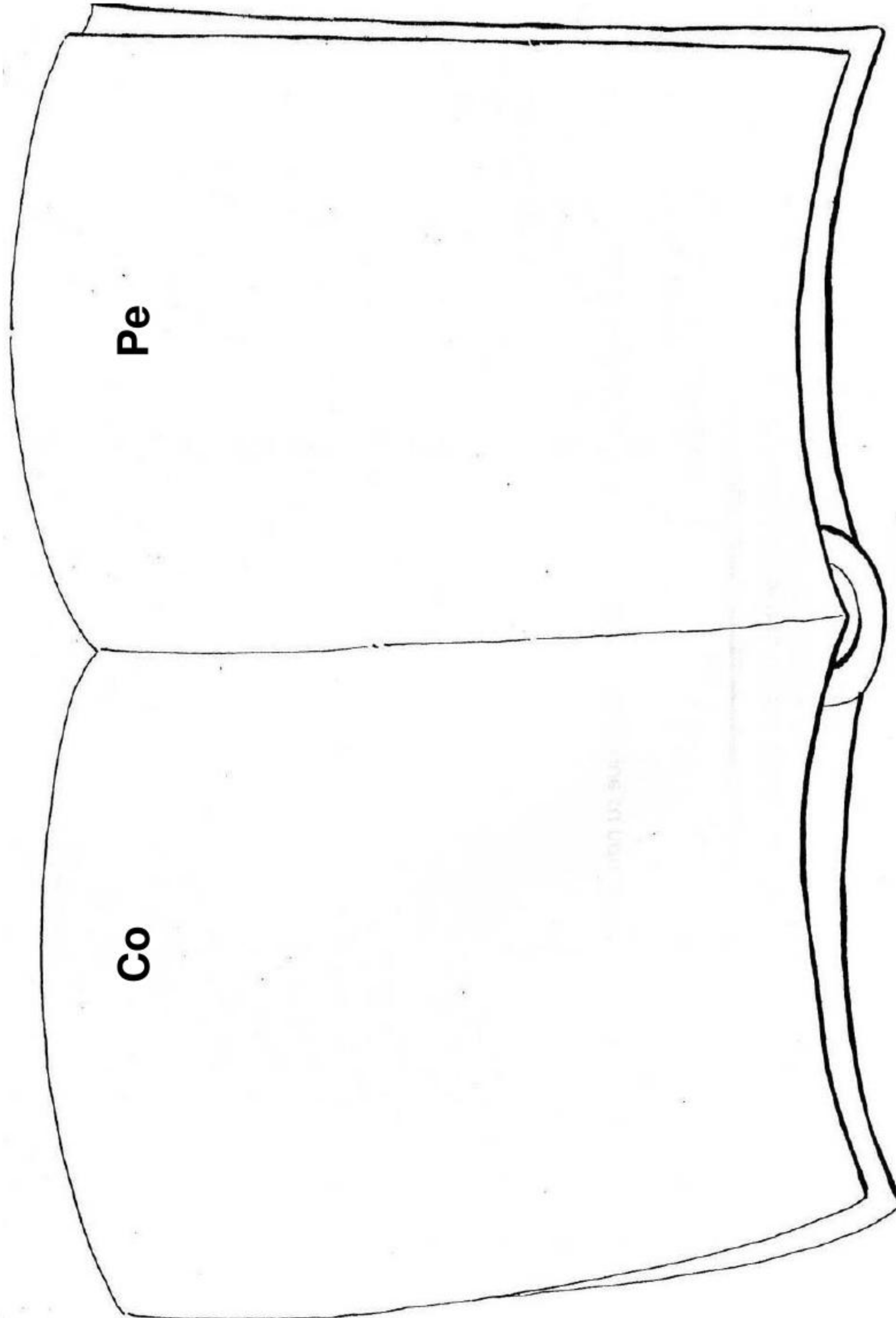

Estímulos: copa, collar, cocina, cofre, conejo, teléfono, techo, cocodrilo, corazón, tele, tenedor, cola.

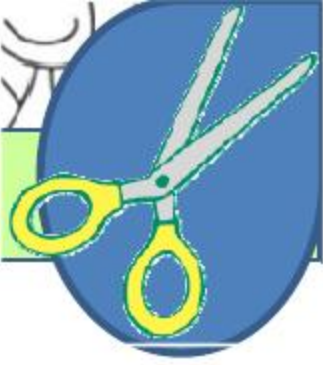

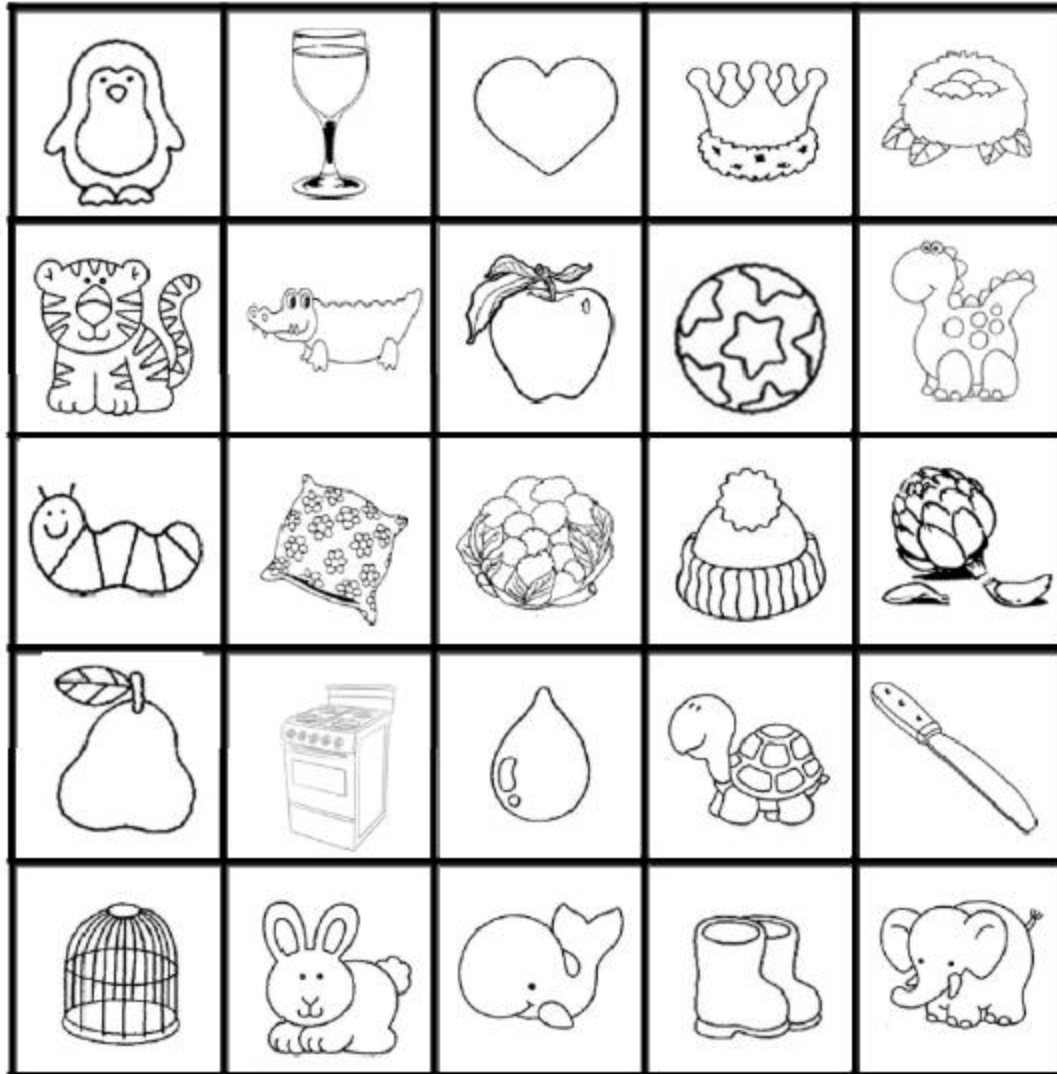

← Pinta las palabras que comienzan con "CO" y descubre la letra que se forma.

Pinta las palabras que comienzan con "PA" y descubre la letra que se forma. →

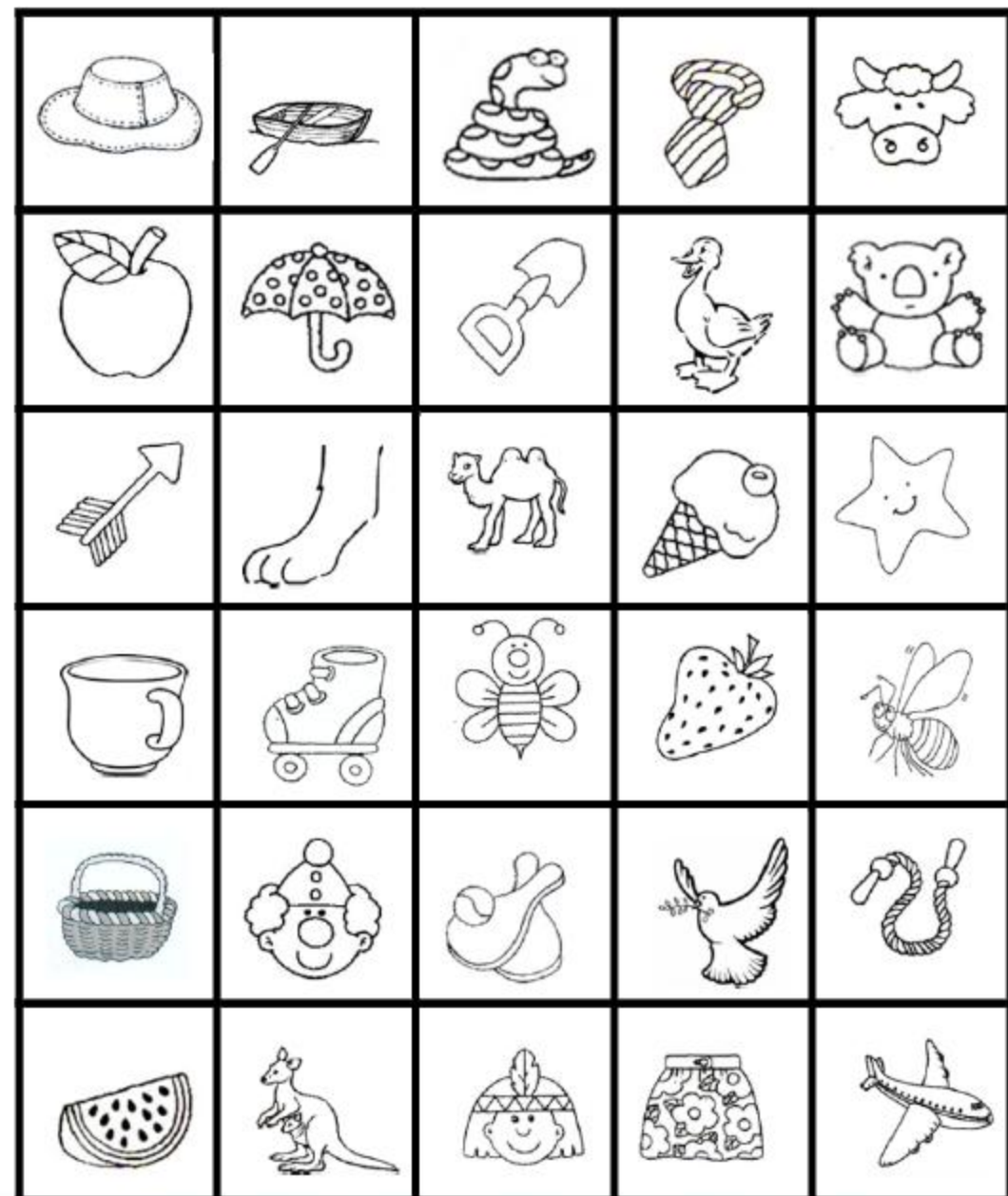

Nombra y colorea la sílaba final.



○ ○ ○ ○



○ ○ ○ ○

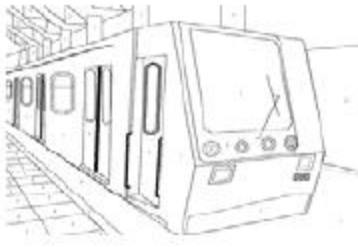

○ ○ ○ ○



○ ○ ○ ○



○ ○ ○ ○



○ ○ ○ ○



○ ○ ○ ○



○ ○ ○ ○



○ ○ ○ ○



○ ○ ○ ○



○ ○ ○ ○



○ ○ ○ ○



○ ○ ○ ○



○ ○ ○ ○

Actividad complementaria: ¿a qué categoría semántica pertenecen las imágenes?, busca otros elementos que pertenezcan a esta categoría y describan cada elemento.



Une con una línea los dibujos que tienen la misma sílaba final.

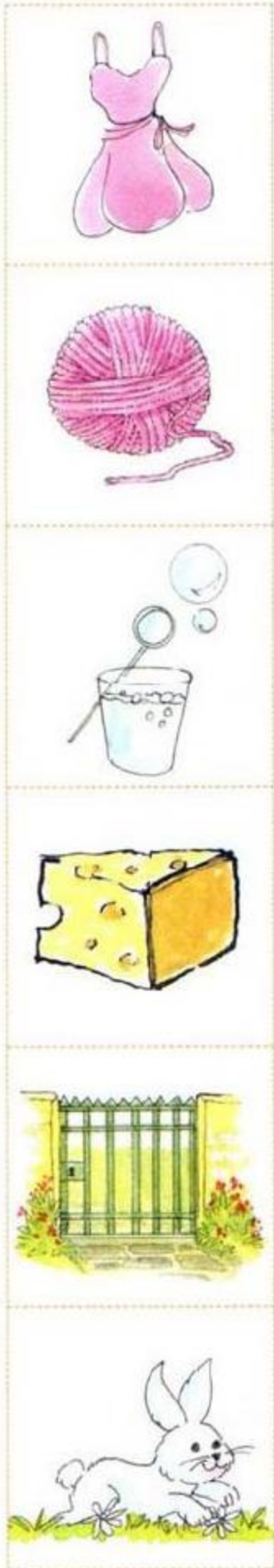



Recorta las figuras y pega cada elemento que completa la oración con el mismo sonido final. Imágenes recortables en la página 89.

El gato salió a jugar con el...

1

La oveja se quedó detrás de la...

2

La ardilla se escondió detrás de la...

3

Vi un elefante muy elegante que usaba un solo...

4

La rana se escapó por la...

5

La tortuga le gusta mucho la...

6

Observa y encierra los elementos que tienen el mismo sonido final que el modelo.

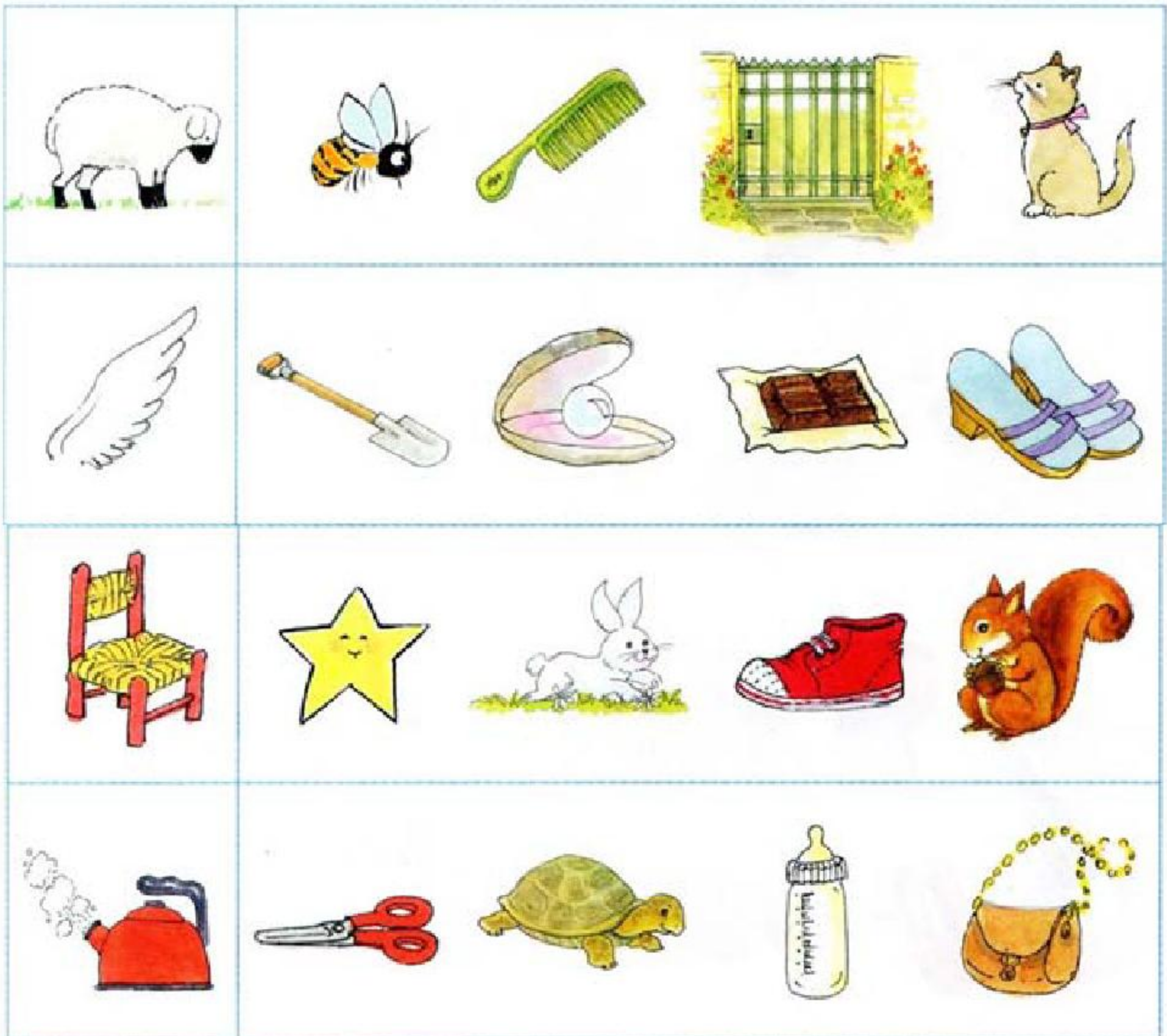

Junta los dibujos que riman. Coloca el signo que corresponde.

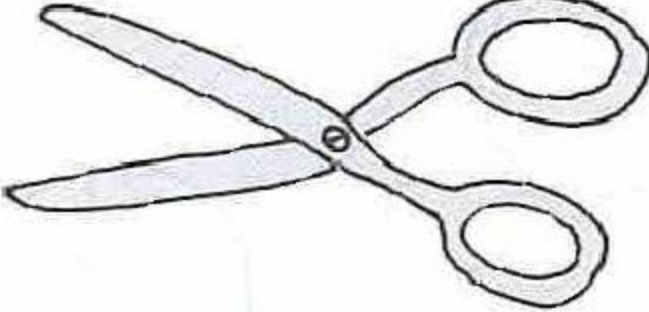
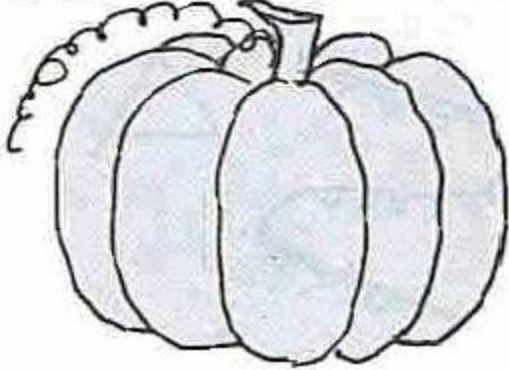
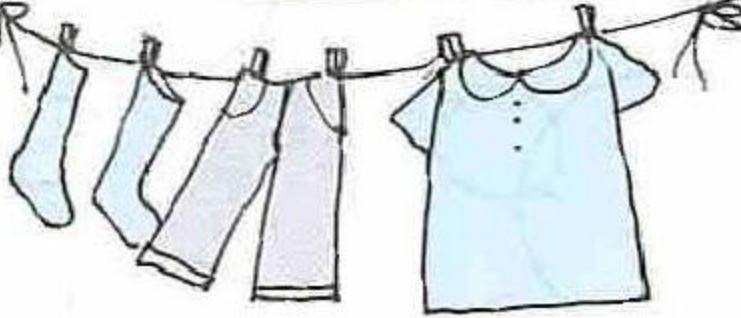
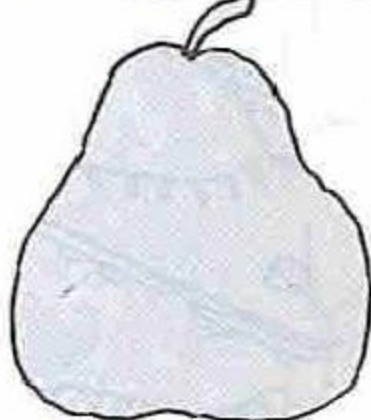
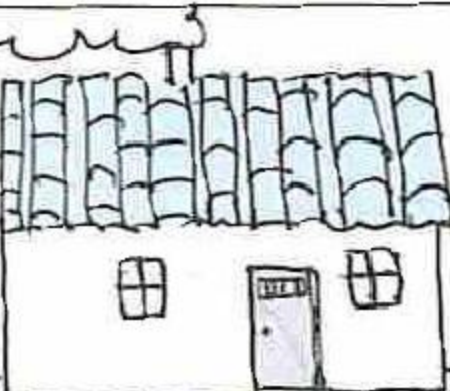
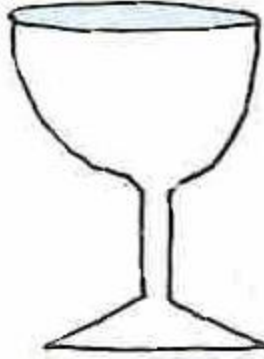
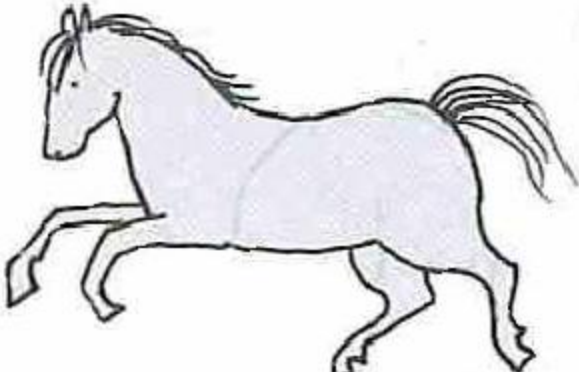
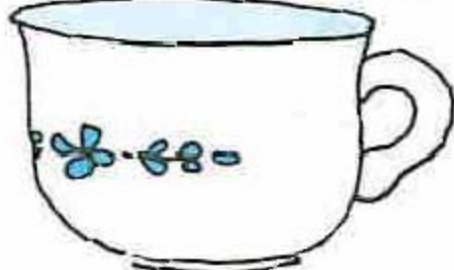
Repite en voz alta el nombre de cada figura y colorea aquellas cuyos nombres riman. Repasa con colores las letras que riman. Tacha la palabra que no rima.

				
CAMPANA	MANZANA	BANANA	ABEJA	VENTANA
				
HELADO	CANDADO	DADO	PESCADO	FLOR
				
ESPEJO	HOJA	CANGREJO	CONEJO	VIEJO
				
CUCHILLO	AUTO	RASTRILLO	CASTILLO	MARTILLO

Marca con una cruz los dibujos cuyos nombres terminen igual que manzana.

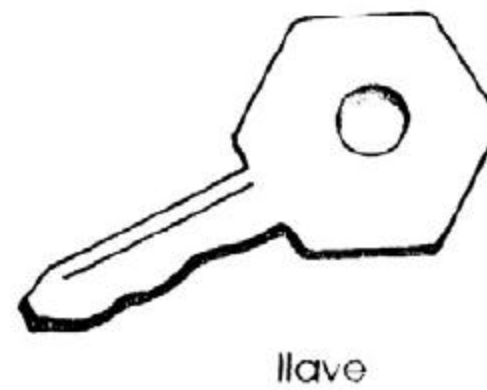
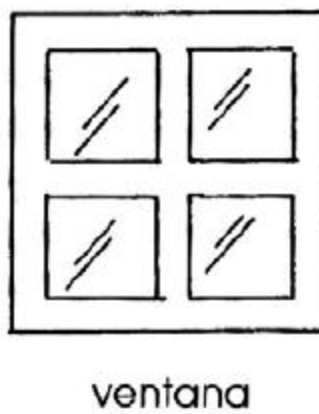
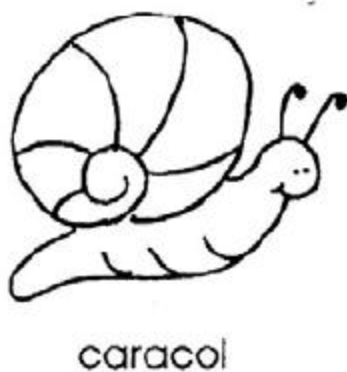
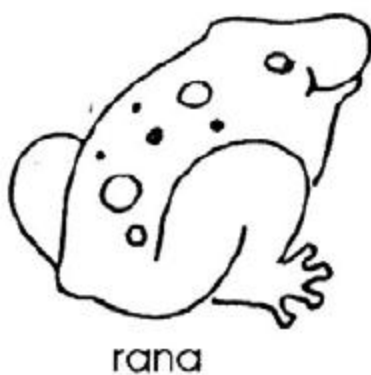

Une con una línea los dibujos que riman.



Niña

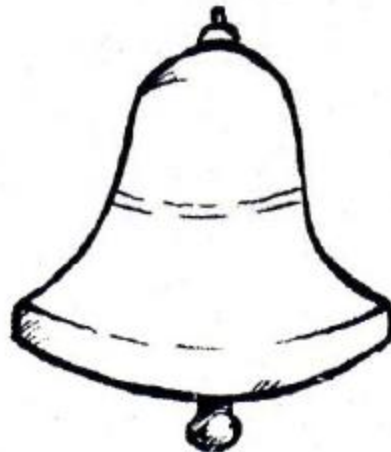

Campana



Frutilla



Piña



Foca

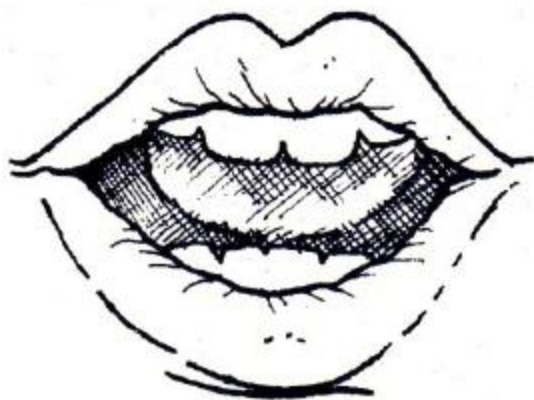

Boca



Silla

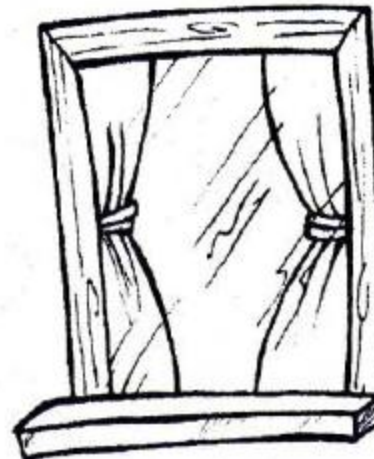

Ventana



Pelota



Bota

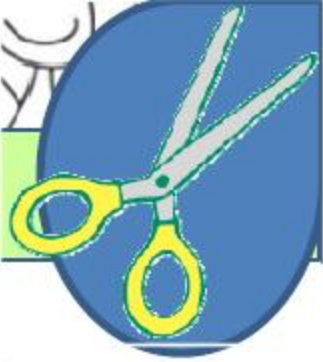

Recorta las imágenes de la página 90 y pégalas junto al dibujo con el que rime .

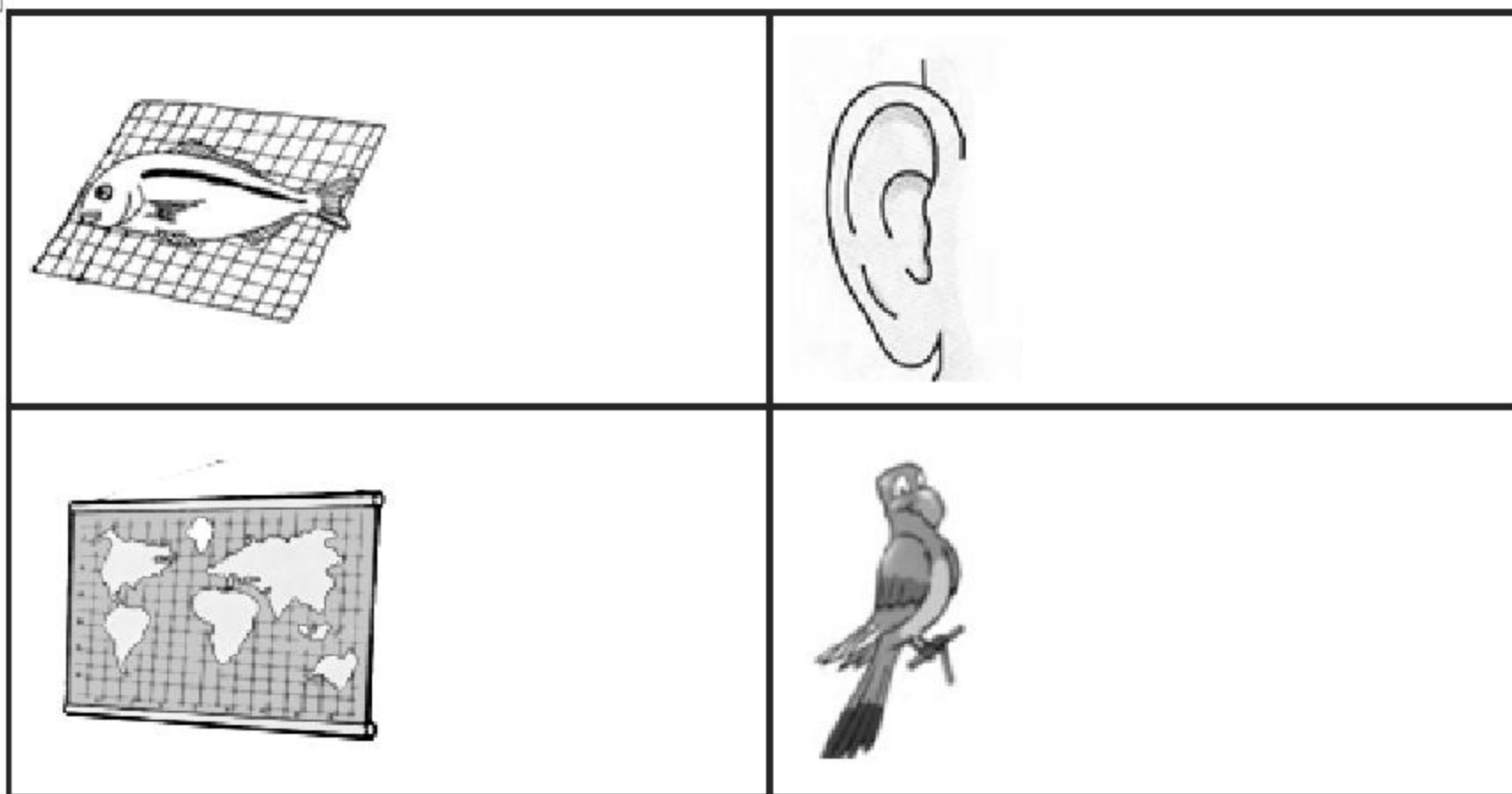
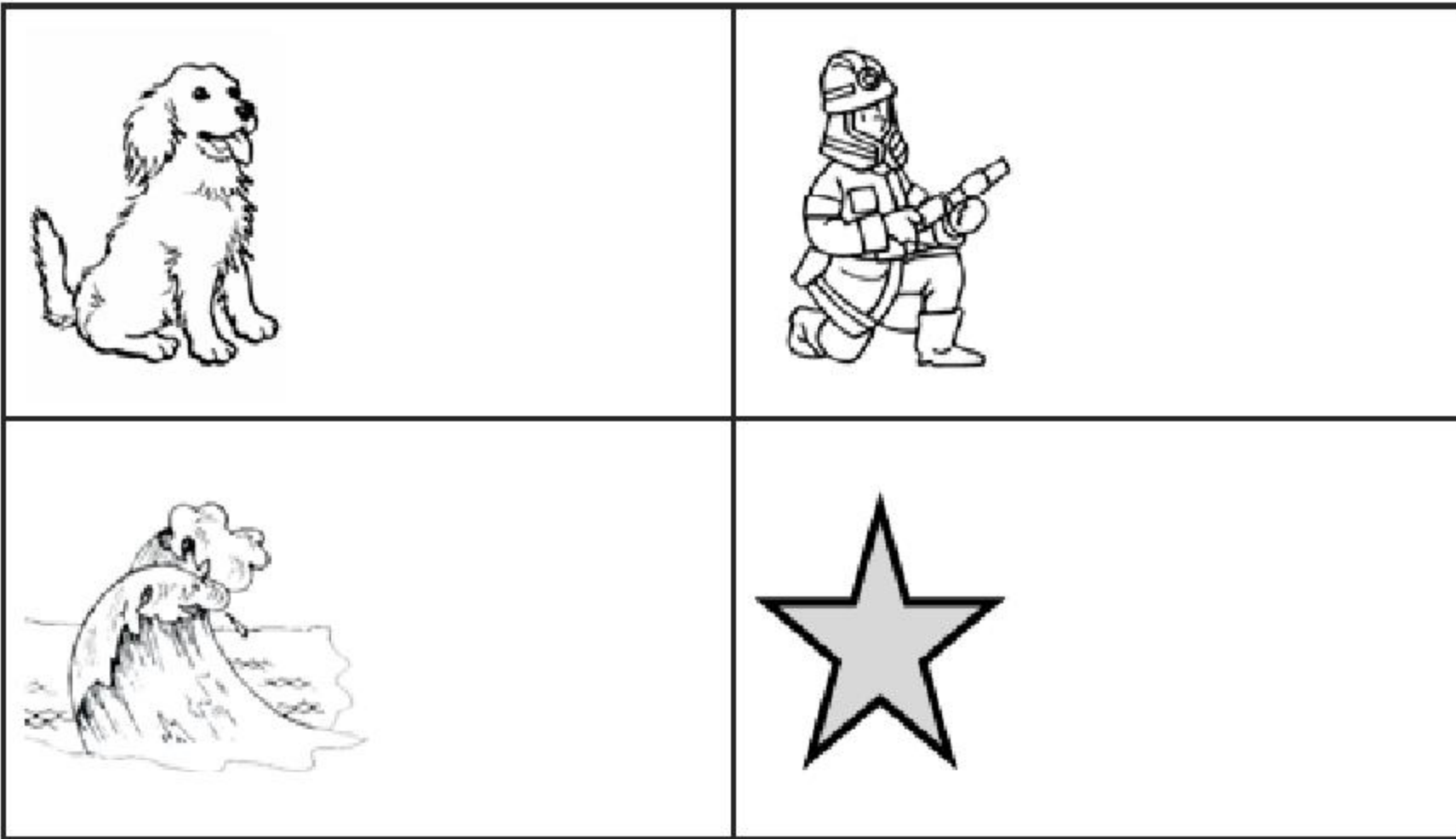

Pinta los objetos que riman en cada fila.

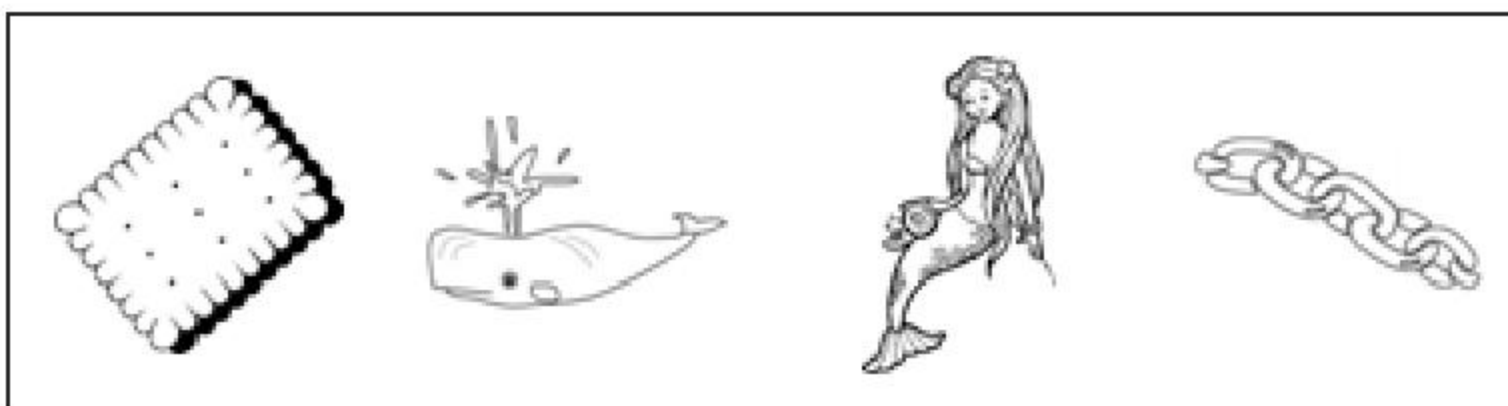
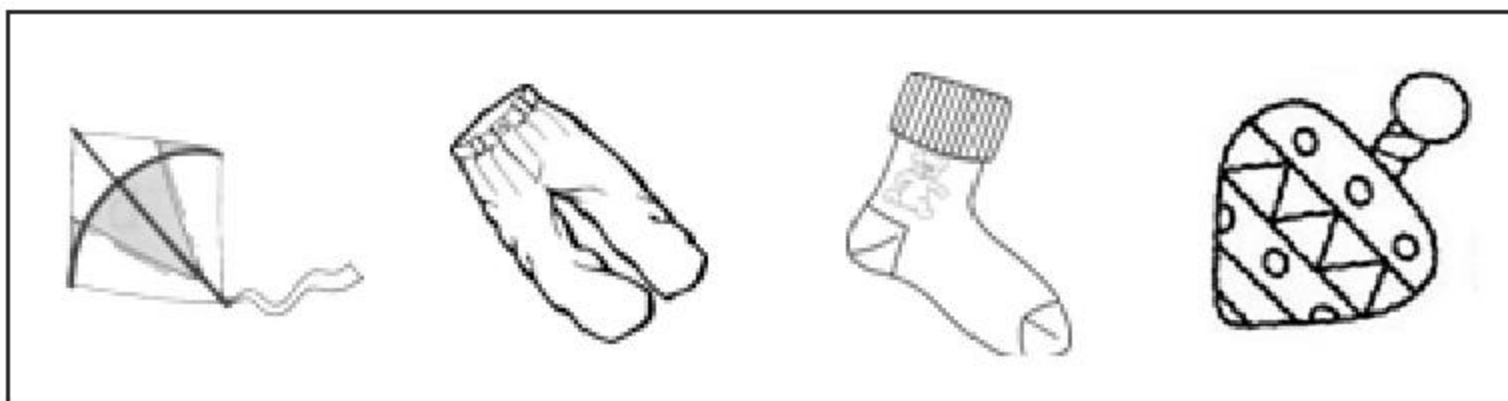
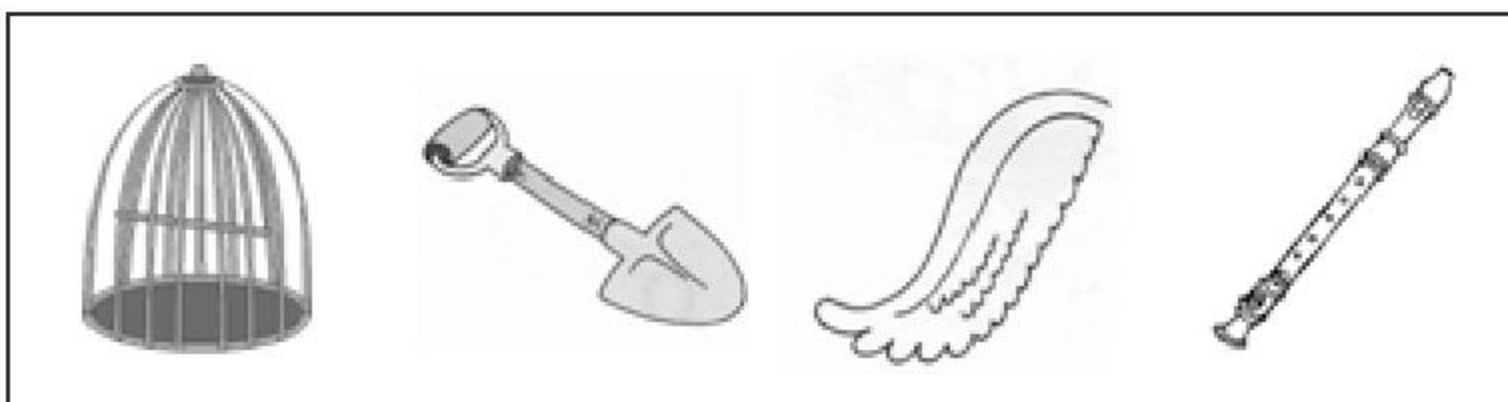
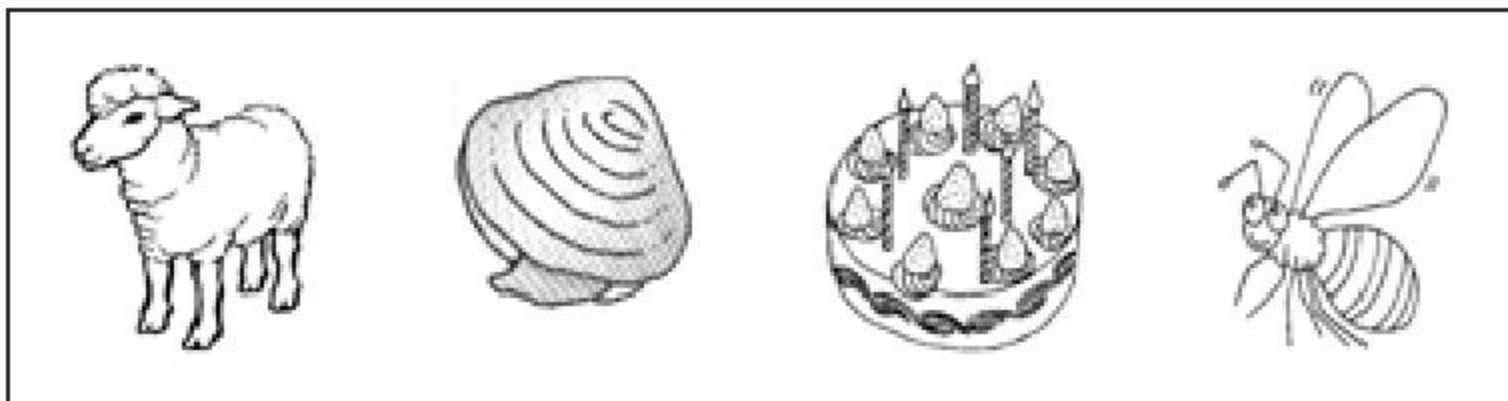

Claudia Arenas Ampuero. Fonoaudióloga

Pinta de igual color las parejas de palabras en que la sílaba final de una corresponde a la sílaba inicial de la otra.



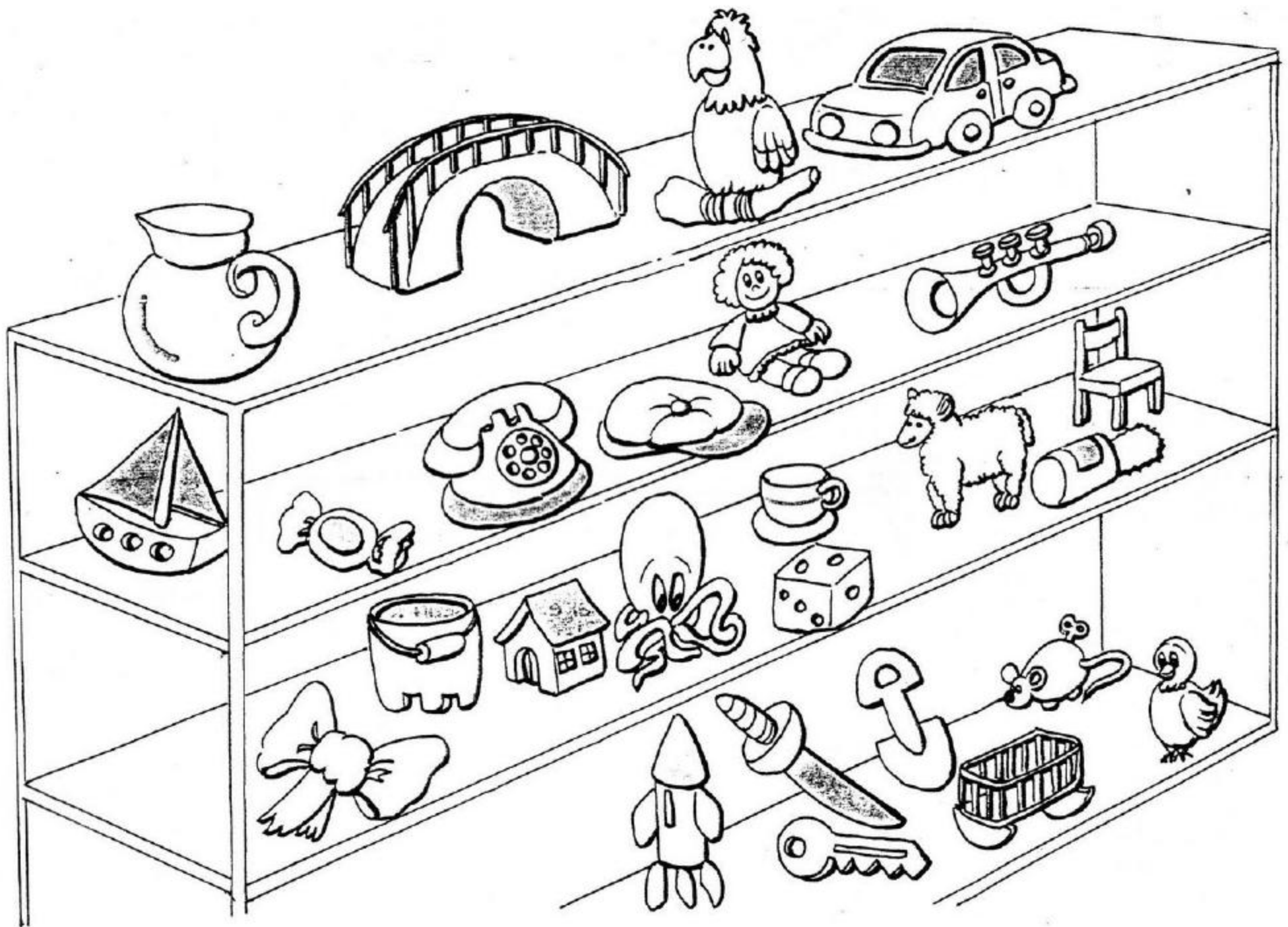





Ejemplo: oveJA – Jarro.



Estímulos: muñeca-casa, puente-teléfono, oveja-jarro, trompeta-taza, espada-dado, cuna-nave, pulpo-pollo, silla-llave.

Haz un dibujo en cada recuadro cuyo nombre comience con la sílaba final de la palabra dada.

Ej: paTO – Tomate.

Di en voz alta y pinta la segunda sílaba.



Di en voz alta y pinta la tercera sílaba.

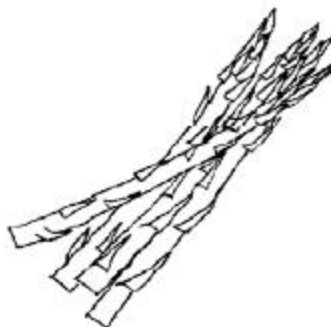

Actividad complementaria: ¿A qué categoría semántica pertenecen las imágenes?, encuentra el elemento intruso. Busca otros elementos que pertenezcan a esta categoría y describan cada elemento.

Une con una línea, los dibujos que tienen igual sonido intermedio, como por ejemplo:

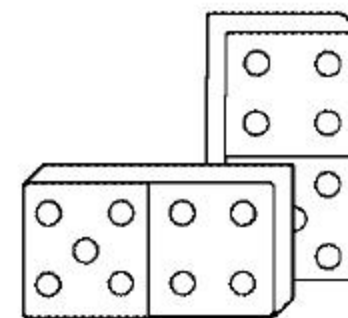
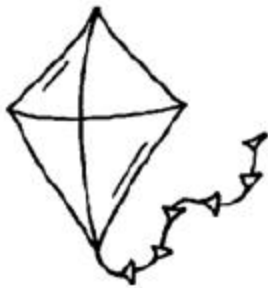
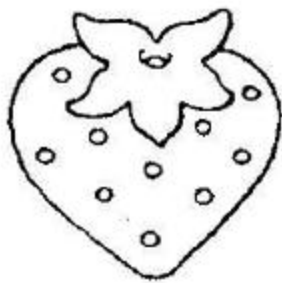
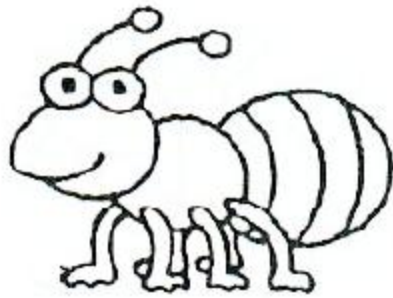
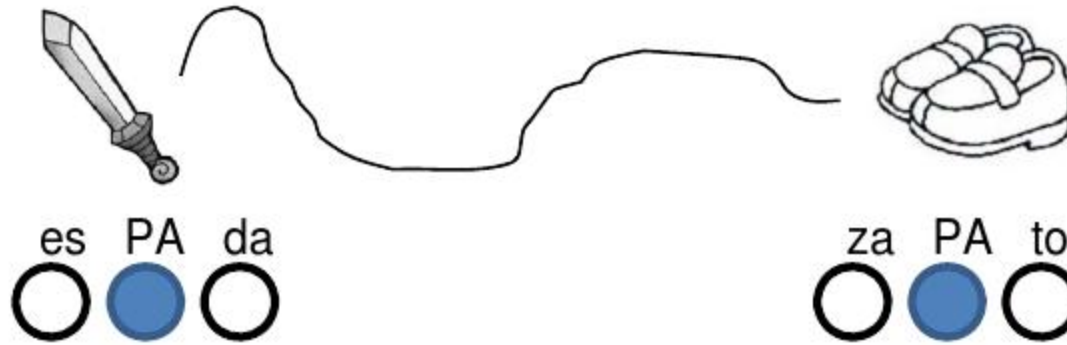

Une con una línea, los dibujos que tienen igual sonido intermedio.

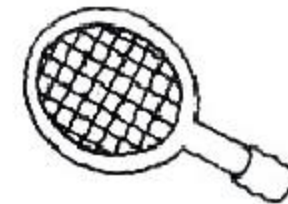
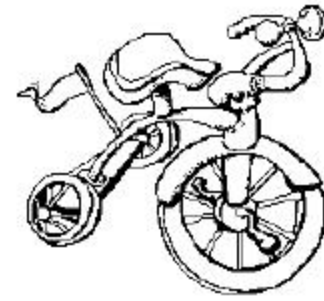



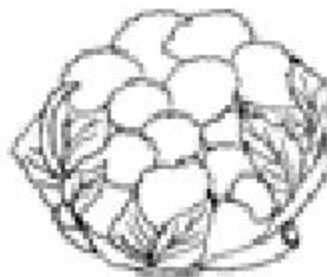





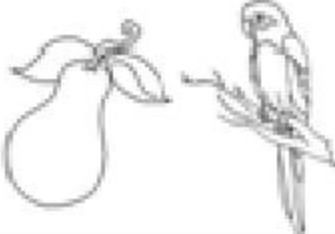
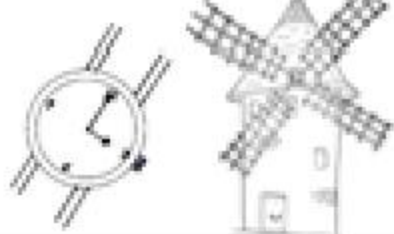
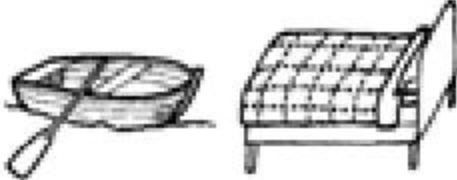

Nombra las sílabas marcadas para encontrar la palabra escondida. Dibuja la palabra escondida.

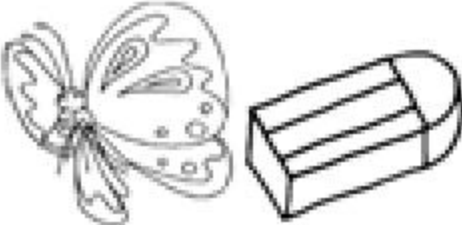

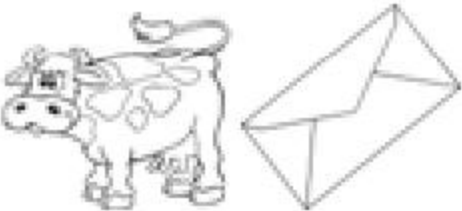
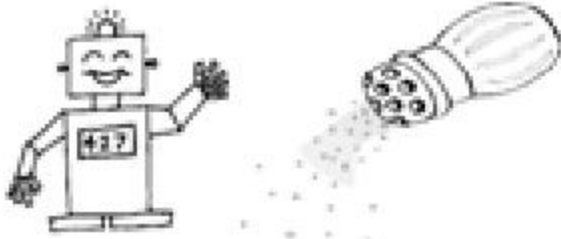
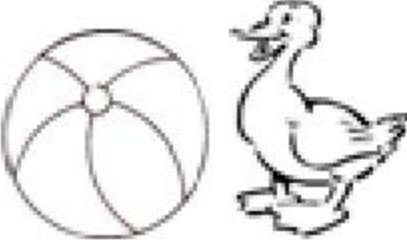
Claudia Arenas Ampuero Fonoaudióloga

Une las primeras sílabas de las palabras que representan los siguientes dibujos y descubre la palabra escondida. Luego dibújala.

Une las últimas sílabas de cada dibujo y encontrarás una palabra escondida. Dibújala.

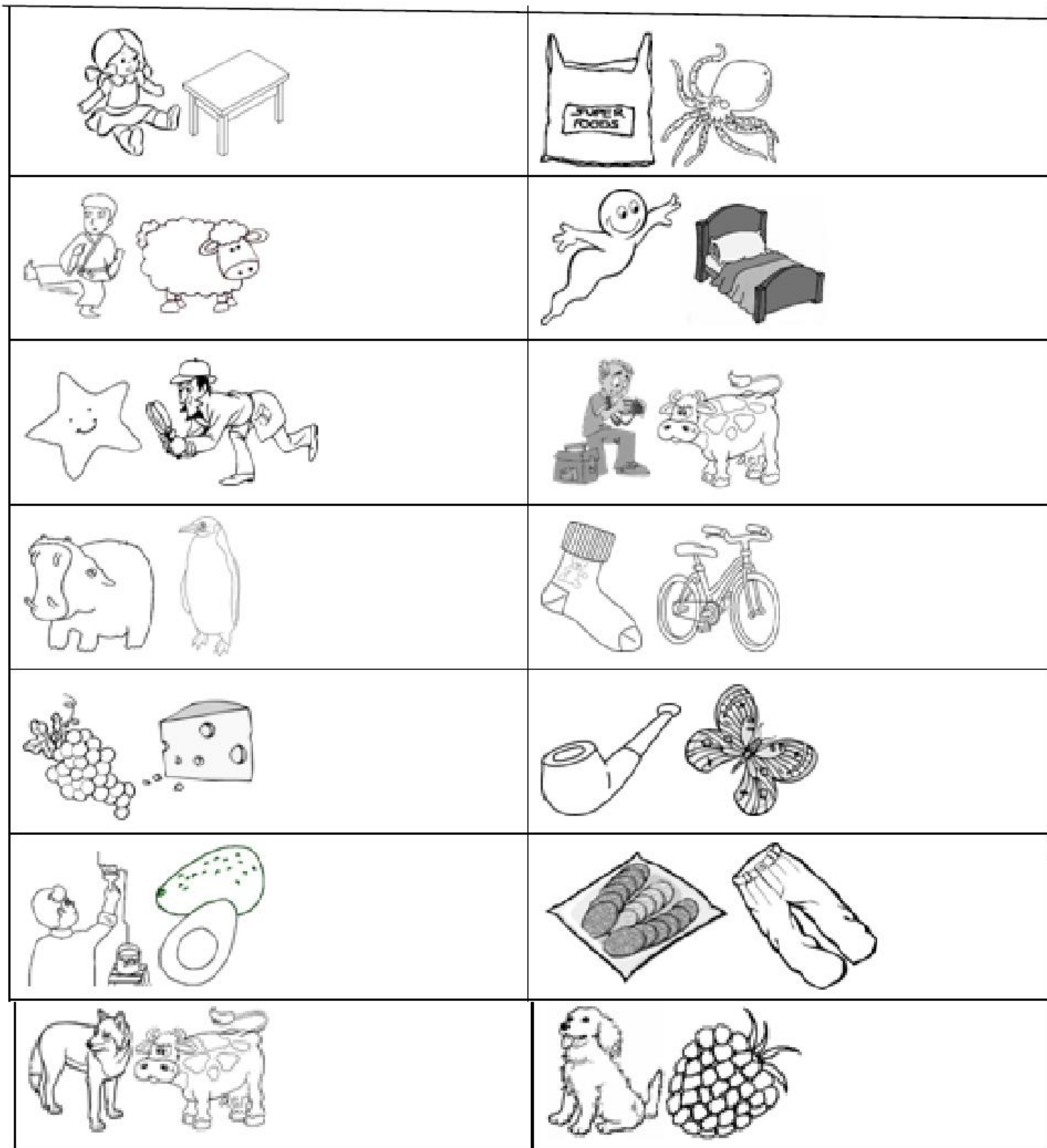

Une las primeras sílabas de las palabras que representan los siguientes dibujos y descubre la palabra escondida .

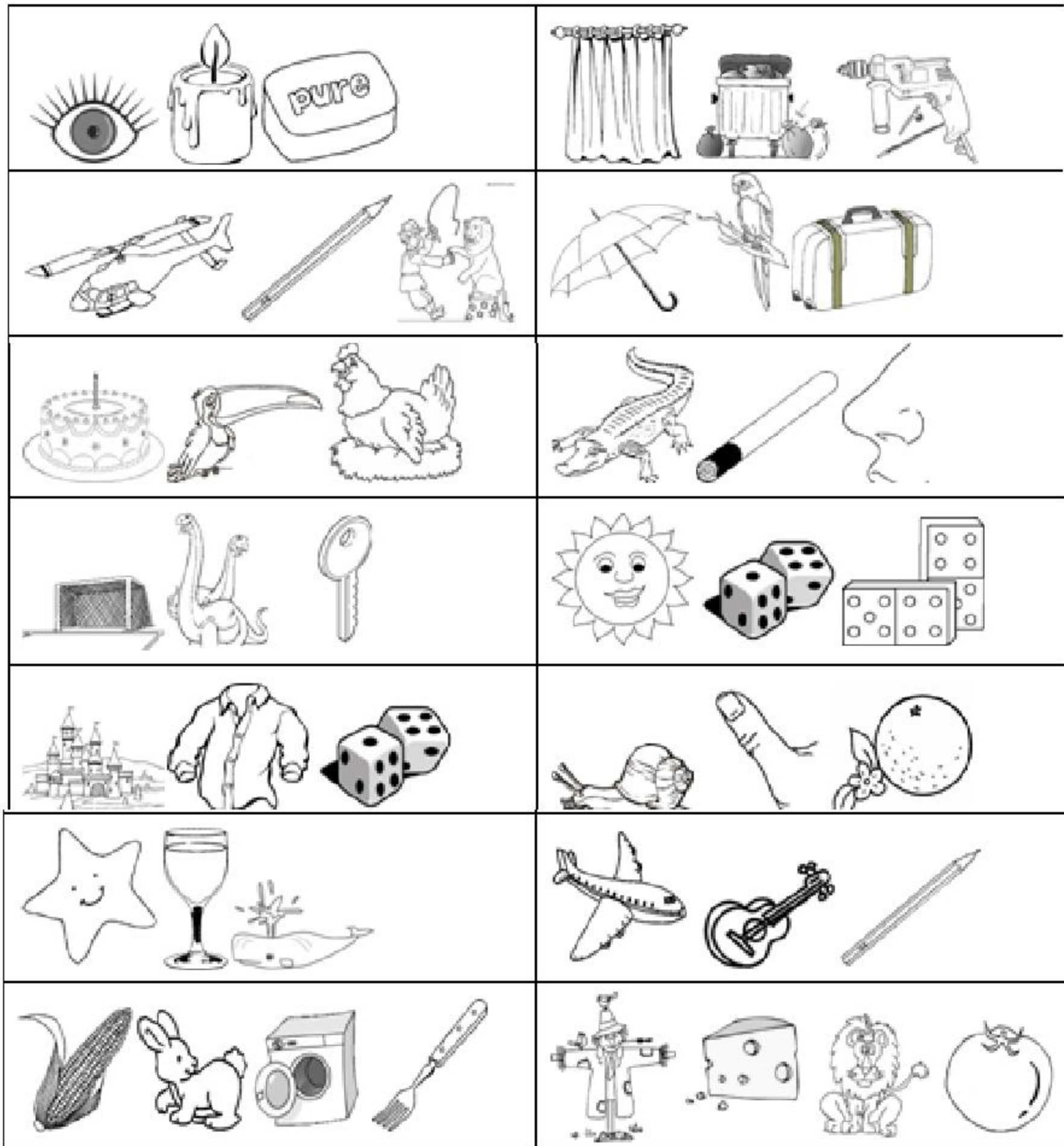

Une las segundas sílabas de cada dibujo y encontrarás una palabra escondida. Dibújala.







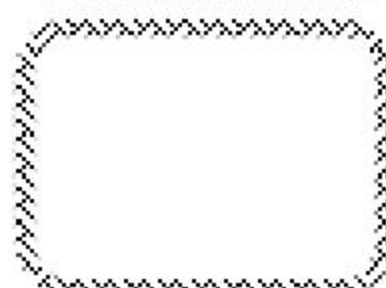
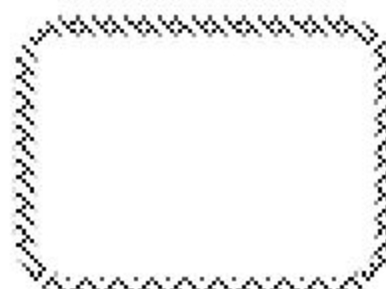
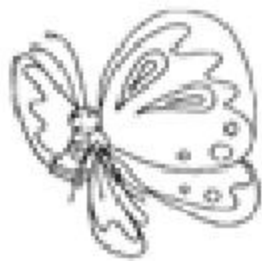











Claudia Arenas Ampuero Fonoaudióloga

Nombra las sílabas marcadas para descubrir la palabra escondida. Dibuja la palabra encontrada.



Claudia Arenas Ampuero Fonoaudióloga

Quita la sílaba que se indica y dibuja el nuevo objeto que se forma.

 - cor X O O	 - ma O O X
 - mi O X O	 - lla O O X
 - za X O O	 - ta O O X
 - li O X O	 - no O O X
 - pan X O O	 - lle O X O
 - gui O X O	 - ne O X O
 - que O X O	 - do O O X
 - sol X O O	 - cor X O O

Observa y lee las palabras de cada renglón.
 Descubre la sílaba que se repite en cada uno y rodéala con color.



□ □ □



□ □ □



□ □ □



□ □ □



□ □



□ □



□ □



□ □



□ □ □



□ □ □



□ □



□ □



Colorea los dibujos que comienzan con la letra A .

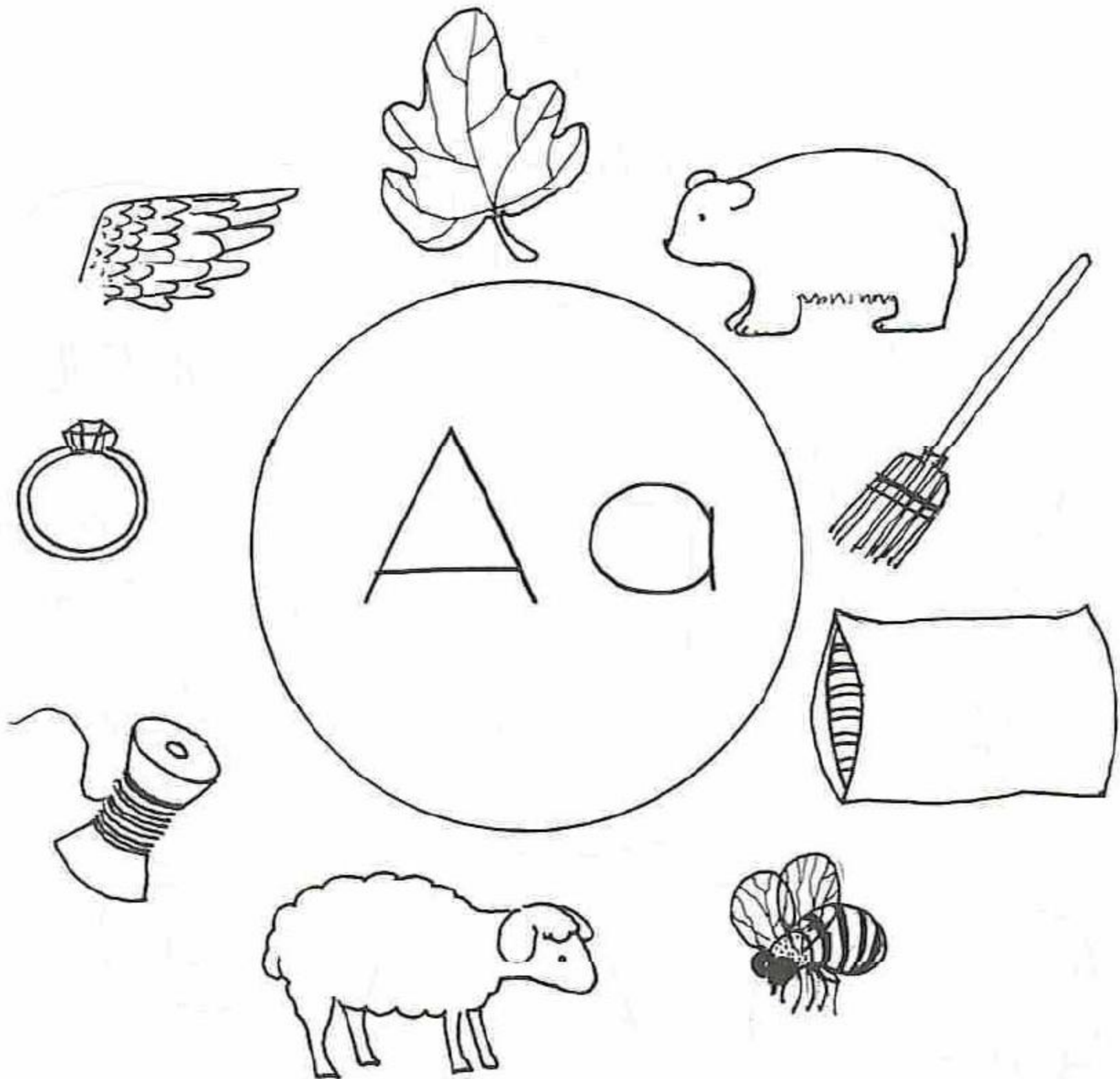

Colorea los dibujos que comienzan con la letra i.

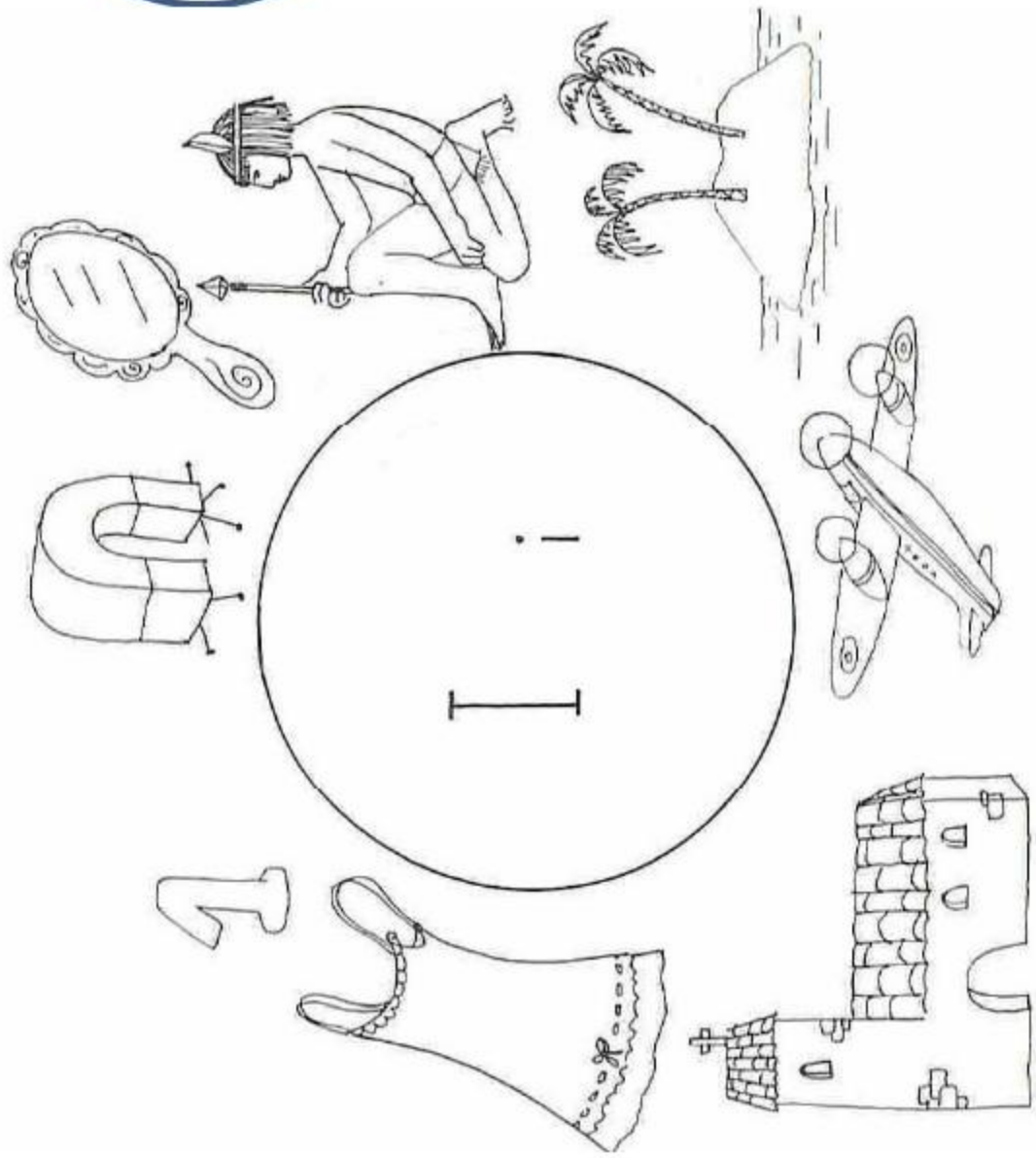

Colorea los dibujos que comienzan con la letra e.

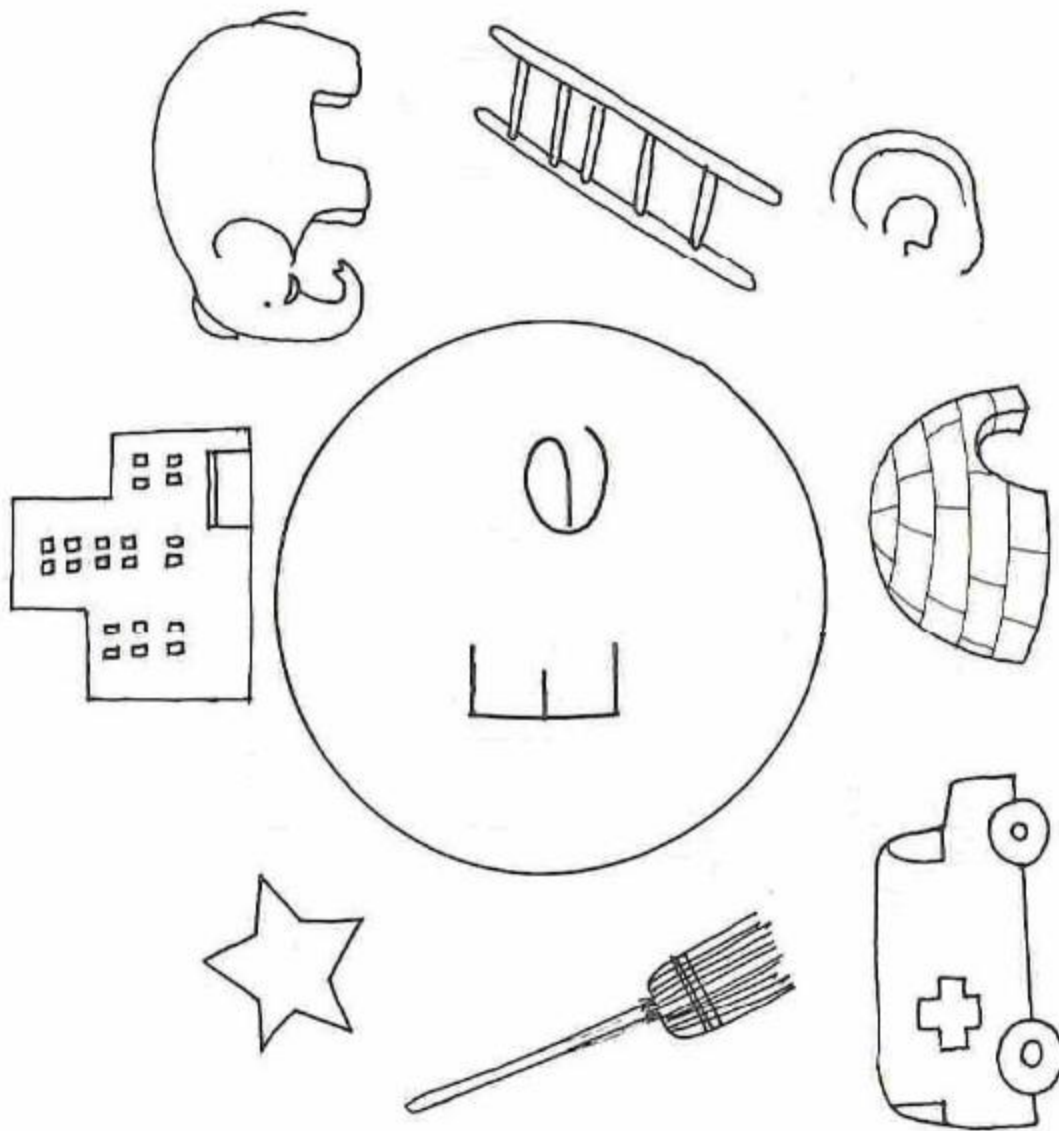



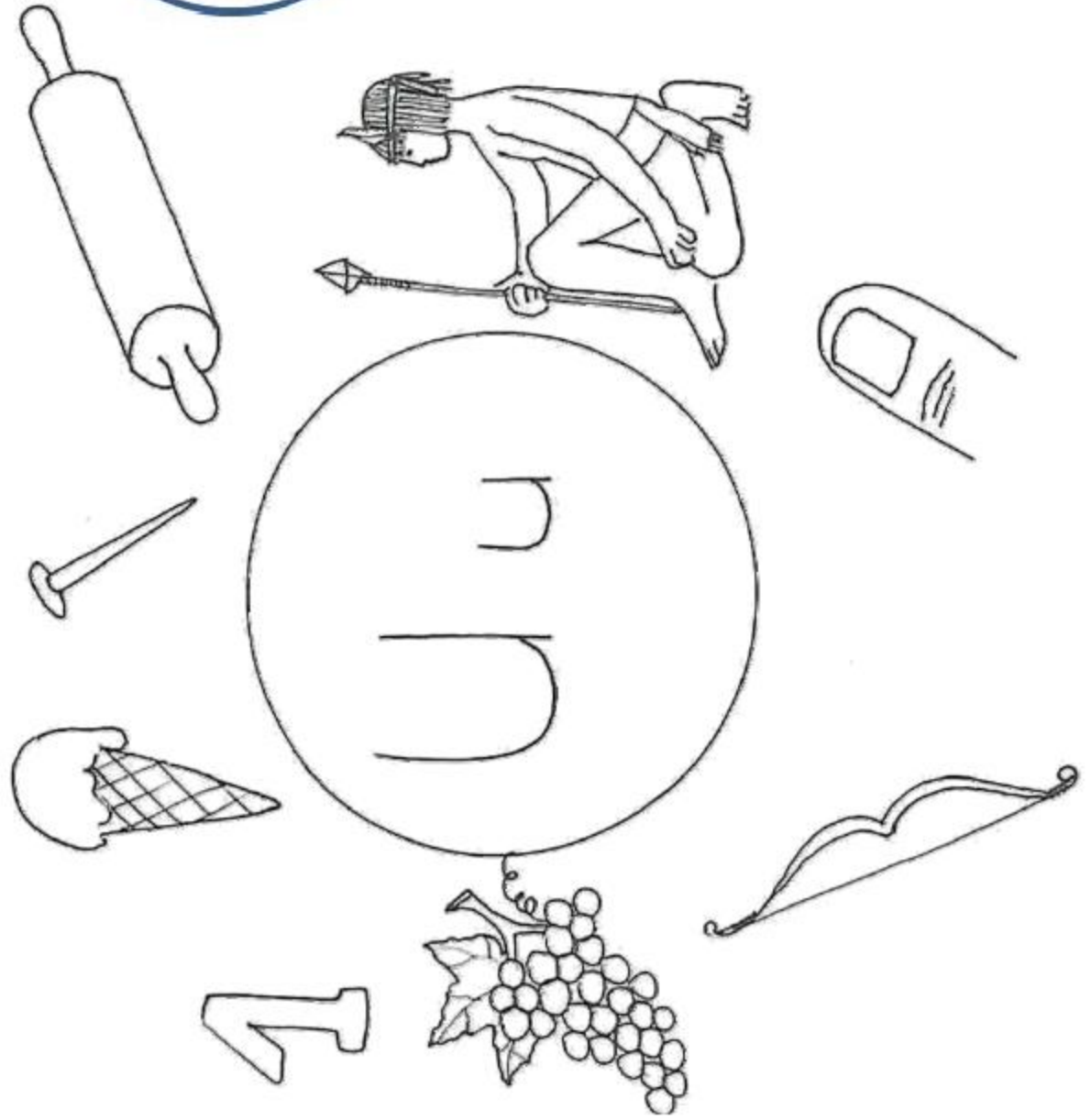



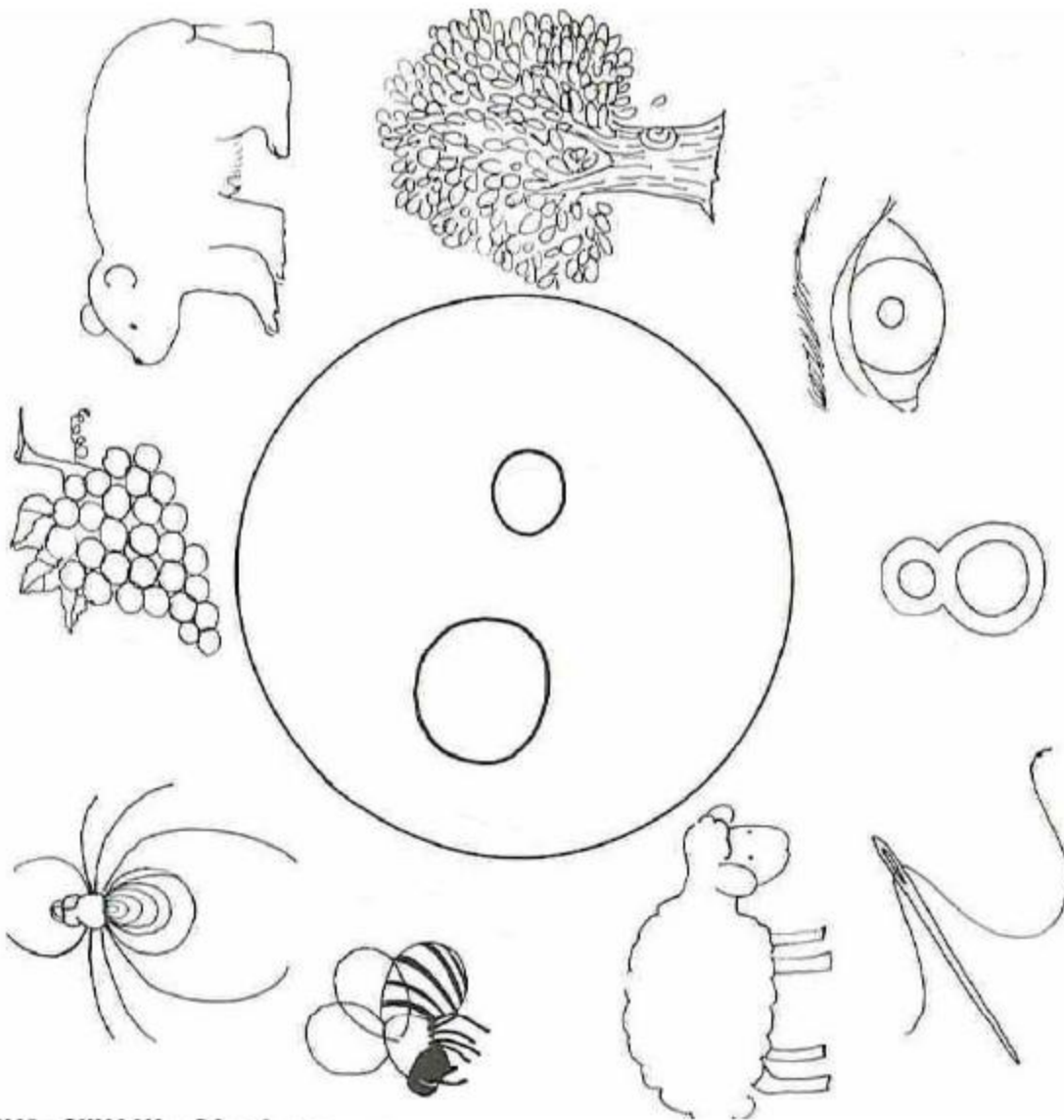









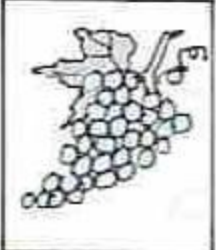



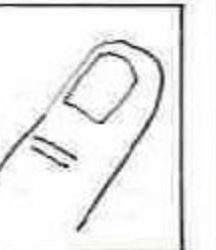

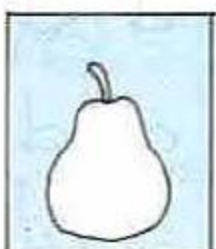
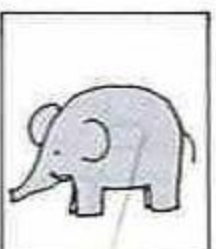



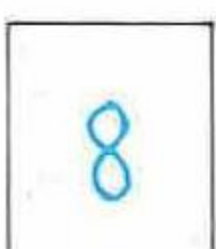
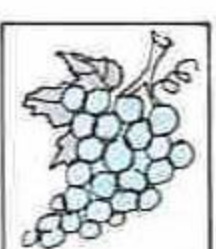
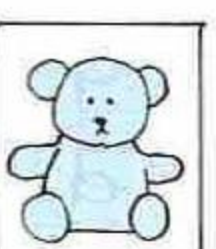

Colorea los dibujos que comienzan con la letra u.

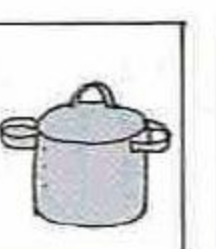

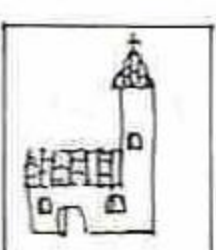
Colorea los dibujos que comienzan con la letra o.

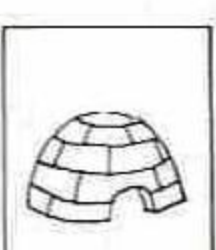

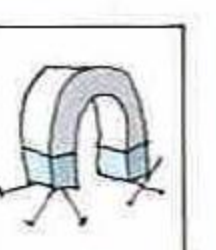
Encierra en un círculo el dibujo que comienza igual al modelo de cada fila.

						
						
						
						
						



Recorta los dibujos de la página 91 y pégalos hacia abajo según corresponda cada vocal.



Encierra en un círculo los dibujos que no comienzan con la misma vocal.

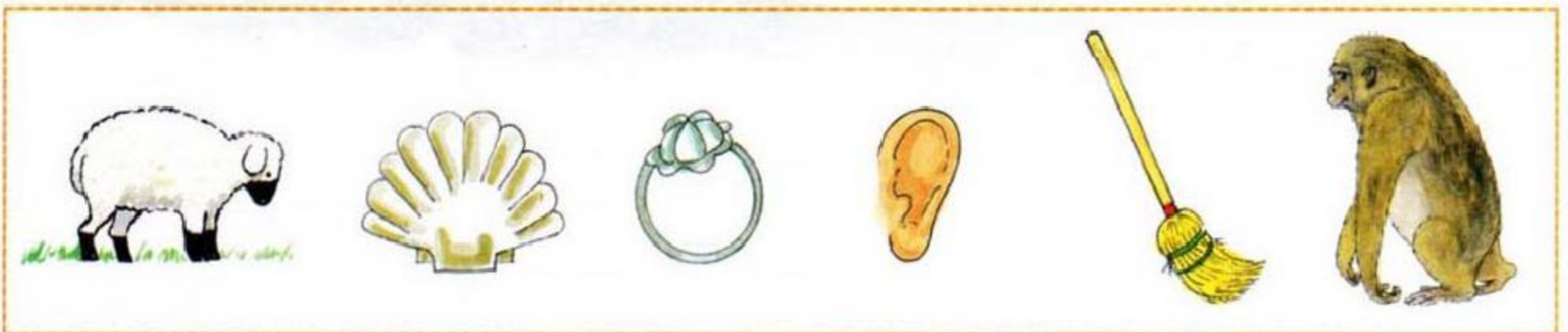

Une con una línea los objetos que tienen el mismo sonido inicial.





Rodea con una línea roja las cosas que tengan en su nombre la letra "i", y con una línea azul las que no tengan en su nombre la letra "i".



Colorea los dibujos que en su nombre aparezca la letra "u".

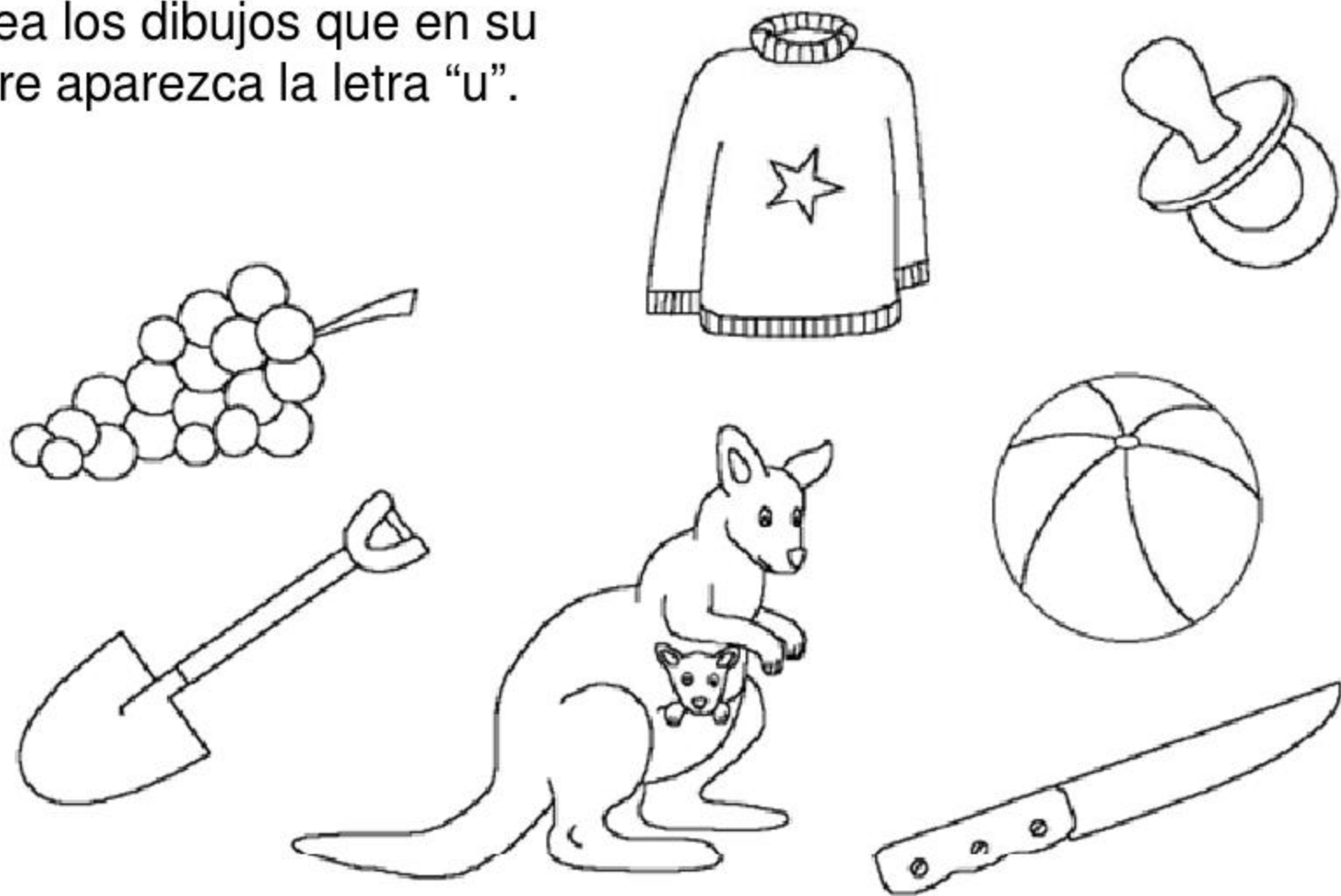

Encierra en un círculo los objetos que en su nombre tienen el sonido "e".

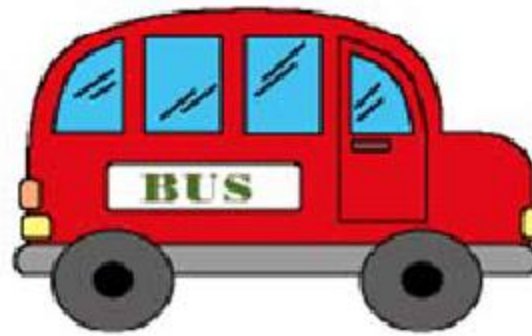

Encierra en un círculo los objetos que terminen con el sonido "a".

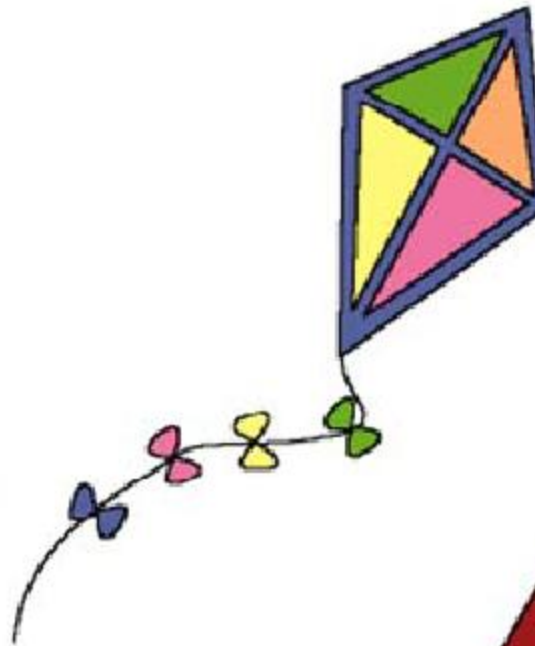

Escribe las vocales que faltan en cada palabra.



B_H_

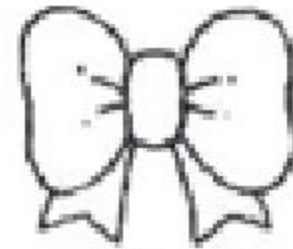

C_NT_

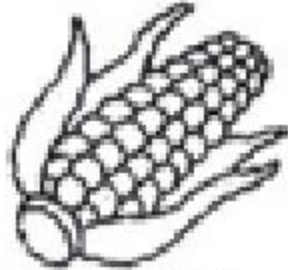

CH_CL_



T_RR_



H__S_



_RB_L



B_LD_



P_T_N



S_G_

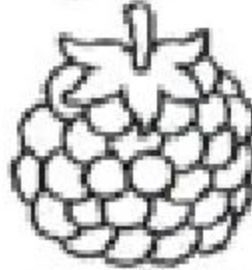

FR_MB_
S



P_T_



CH_NCH_



P_ST_L



G__NT_



_B_J_



P_LL_

Escribe las vocales que faltan en cada palabra.

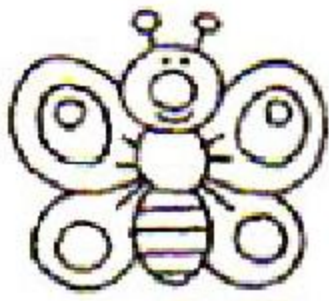

M _ R _ P _ S _

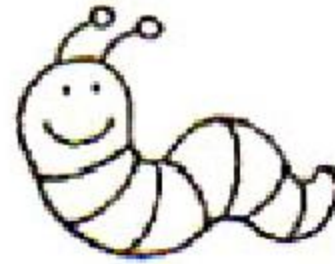

G _ S _ N _



M _ N Z _ N _



P _ C _ R _



_ L _ F _ N T _



M _ M _ D _ R _



_ R _ Ñ _



L _ P _ Z

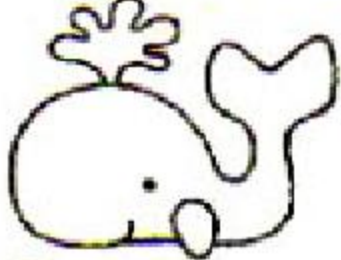

B _ L L _ N _



L _ M _ N



C _ R _ C _ L



_ B _ J _



G _ T _



FR _ T _ LL _



P _ L _ T _



T _ N _ D _ R

Escribe las vocales que faltan en cada palabra.



J _ _ L _



M _ R _ P _ S _

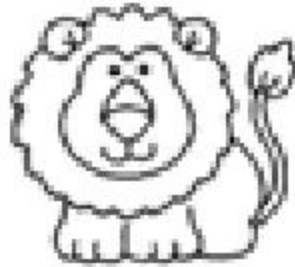

L _ _ N



_ V _ _ N



G _ _ G _ _



P _ N G _ _ N _



K _ _ L _

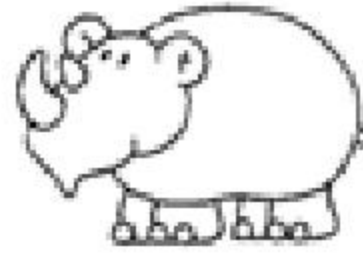

R _ N _ C _ R _ N T _



S _ R P _ _ N T _



_ B _ _ L _



P _ R _ G _ _ S



D _ N _ S _ _ R _ _



M _ R C _ _ L _ G _



_ X T R _ T _ R R _ S ' t r _



G _ _ N T _ S



H _ L _ C _ P T _ R _

Delinea las vocales que contiene cada dibujo.

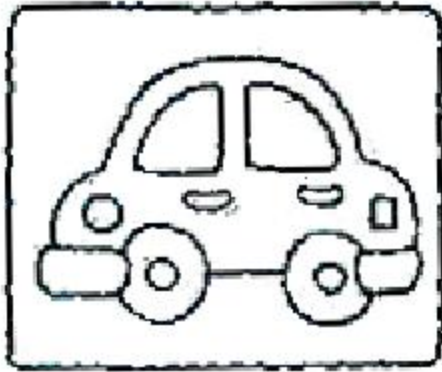

a-e-i-o-u



a-e-i-o-u

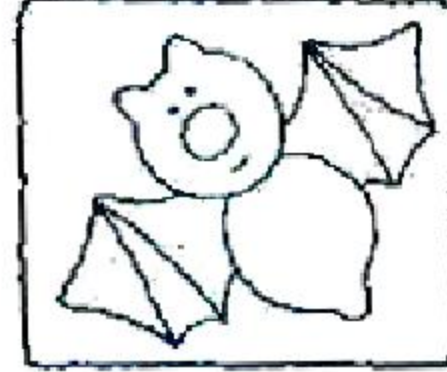

a-e-i-o-u

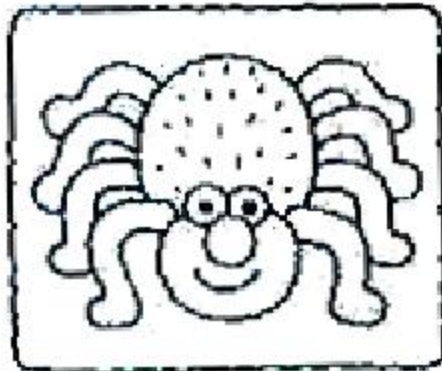

a-e-i-o-u

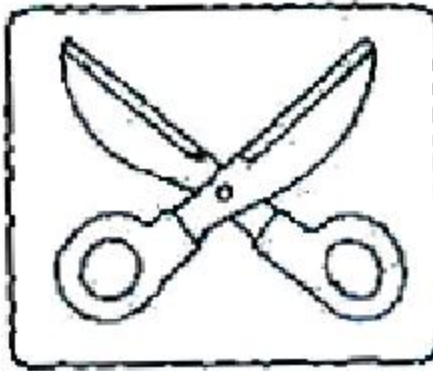

a-e-i-o-u



a-e-i-o-u

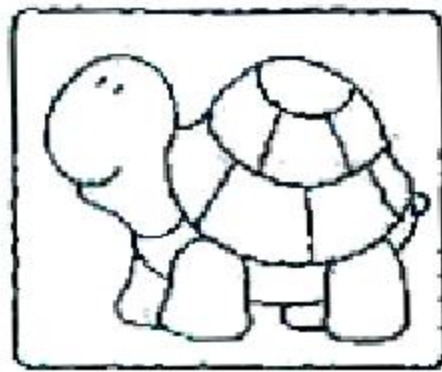

a-e-i-o-u

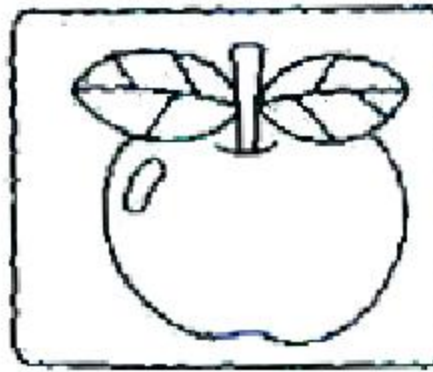

a-e-i-o-u

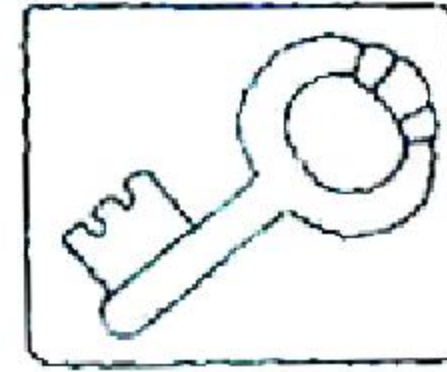

a-e-i-o-u

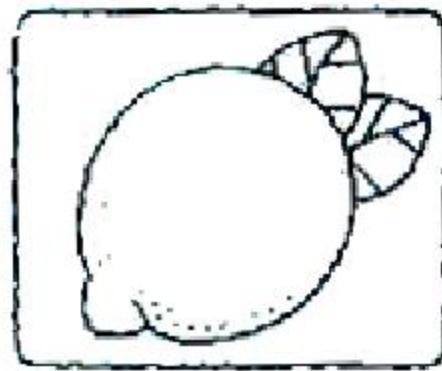

a-e-i-o-u

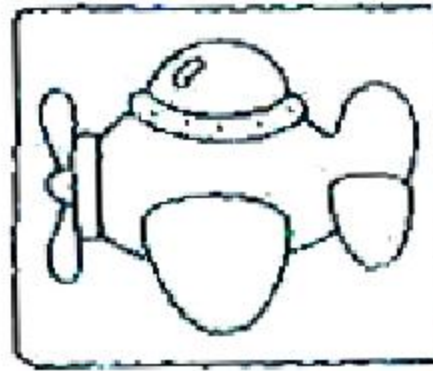

a-e-i-o-u

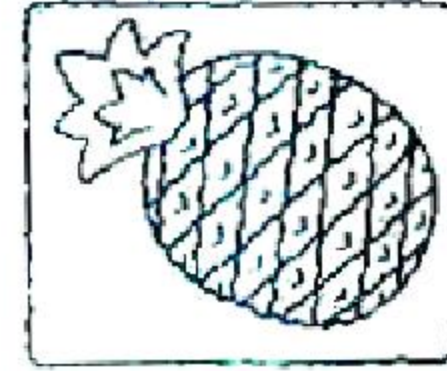

a-e-i-o-u

Encierra en un círculo el dibujo cuya palabra contenga las mismas vocales que el modelo.

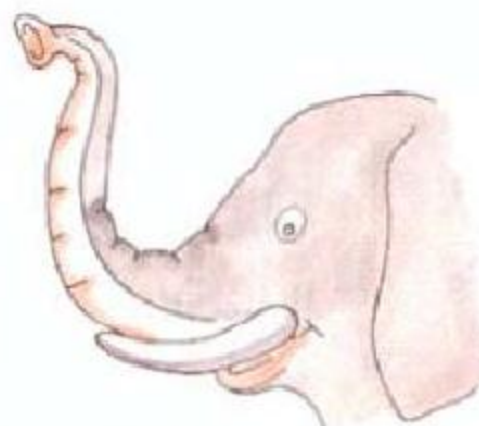
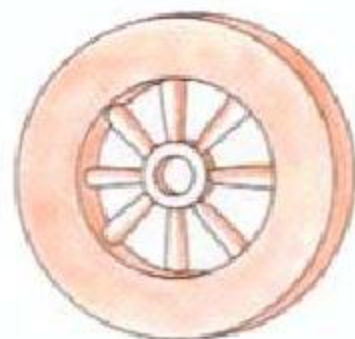
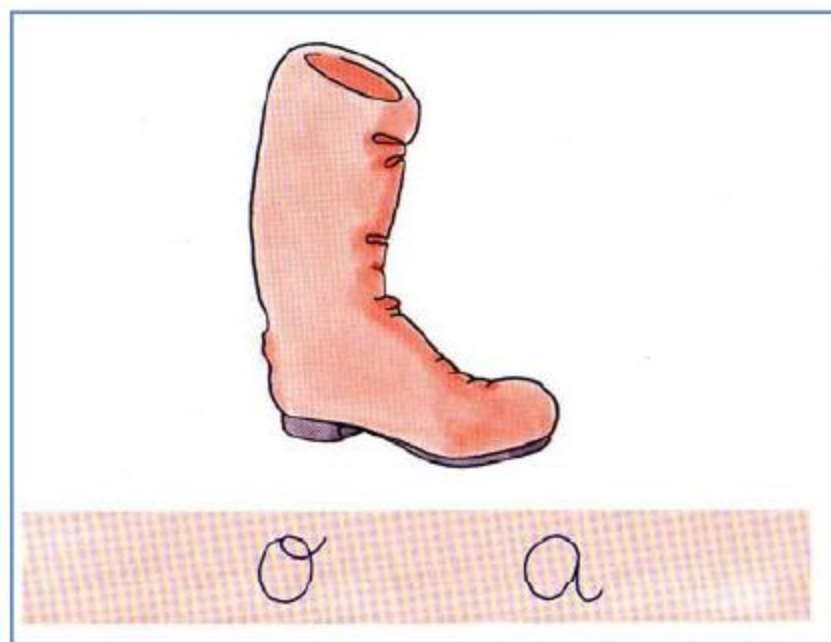

Con un lápiz amarillo encierra en un círculo los dibujos cuya palabra contenga las mismas vocales que el modelo.



Con un lápiz azul encierra en un círculo el dibujo cuya palabra contenga las mismas vocales que el modelo.

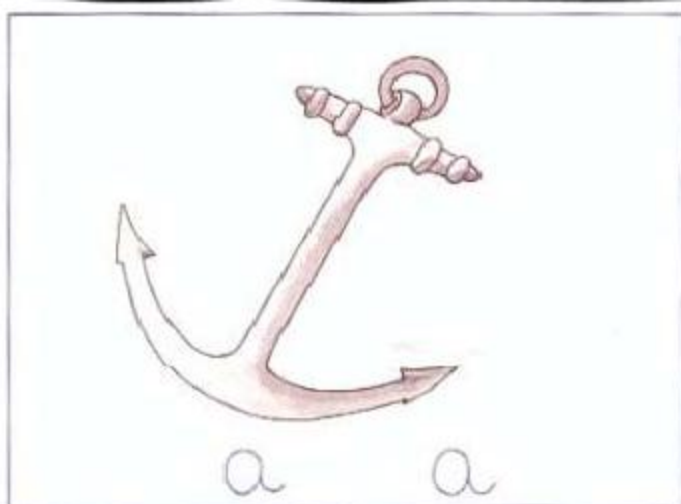
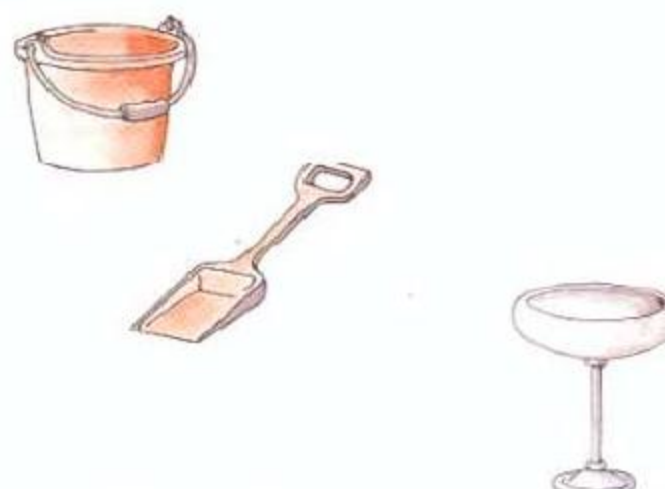
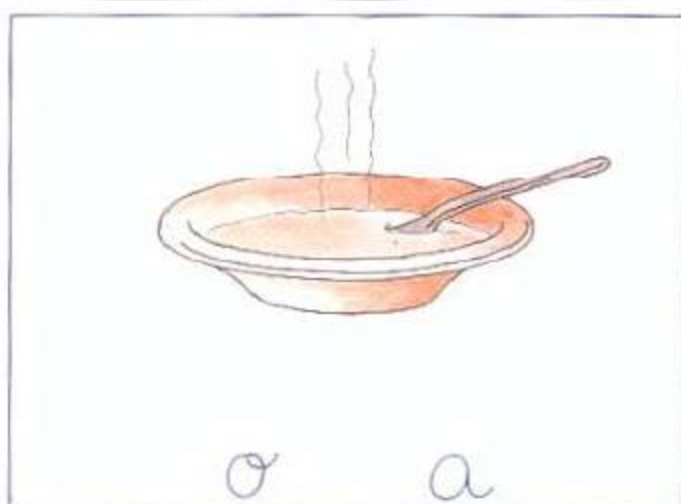
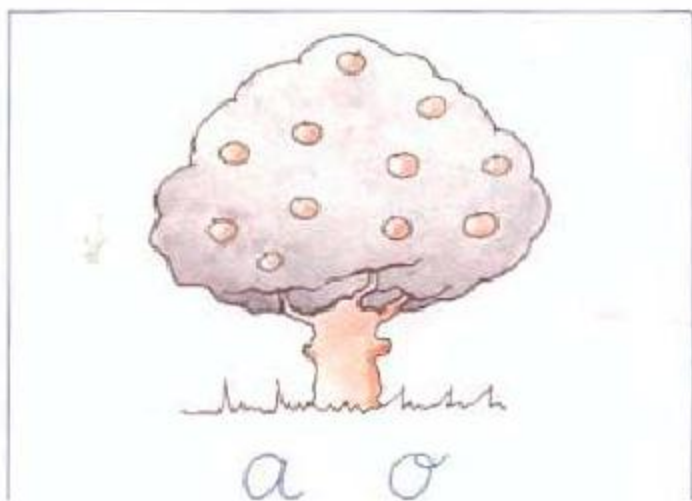

Con un lápiz azul encierra en un círculo el dibujo cuya palabra contenga las mismas vocales que el modelo.

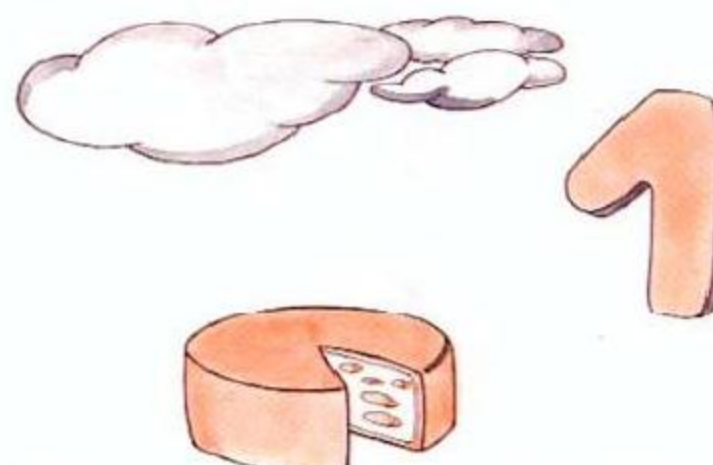
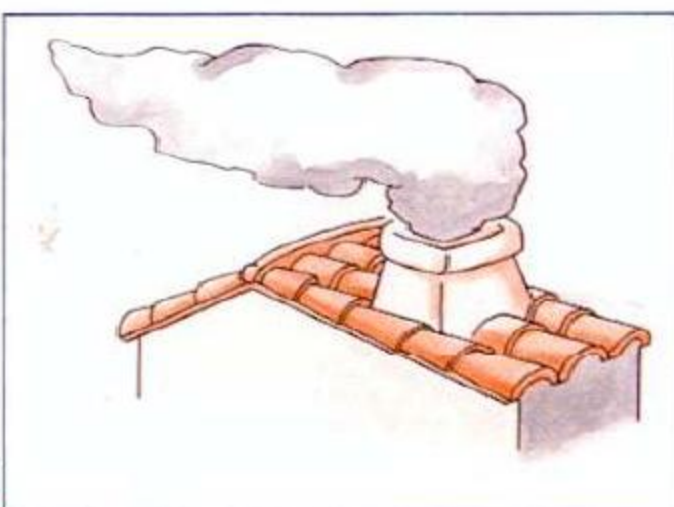
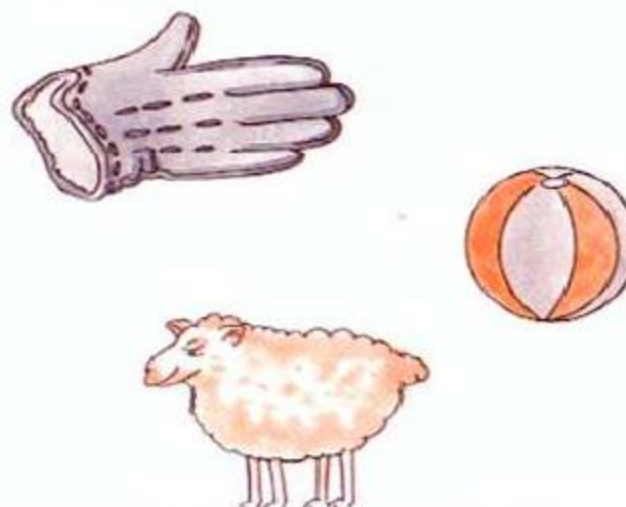
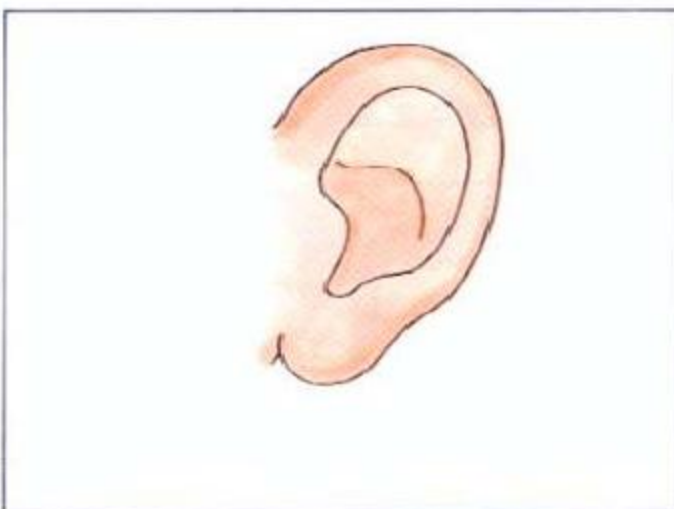
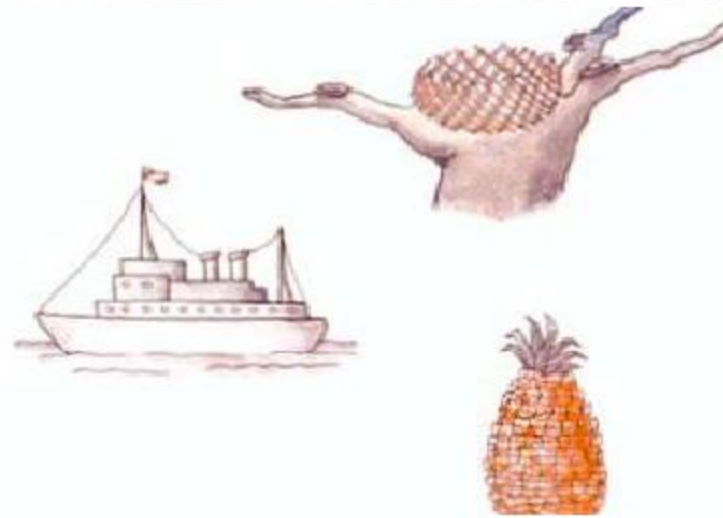
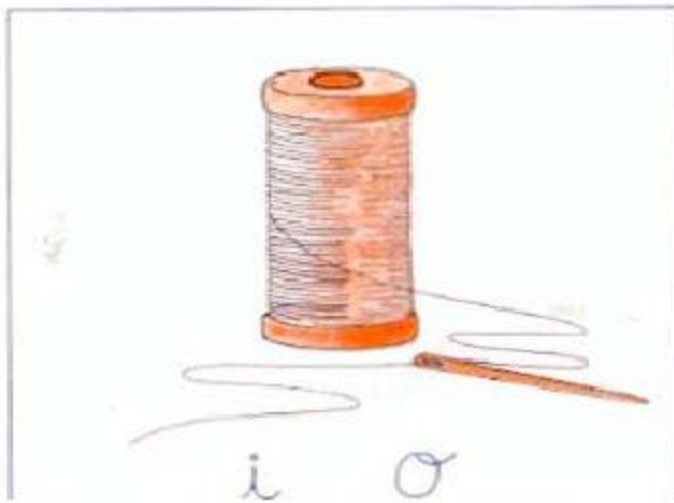



Encierra las figuras cuyo nombre empieza con vocal.

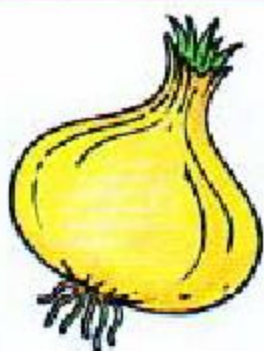
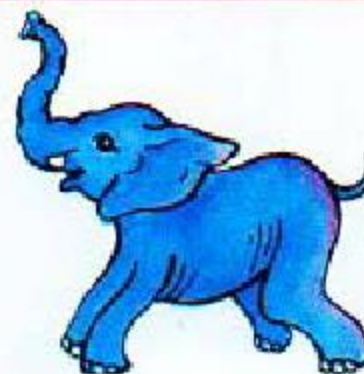
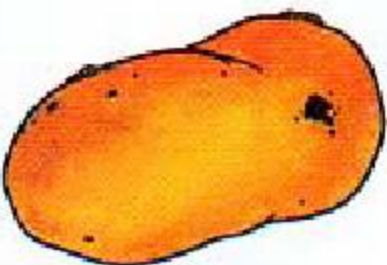
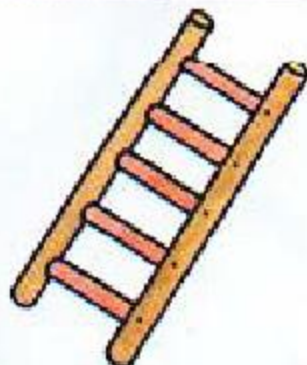
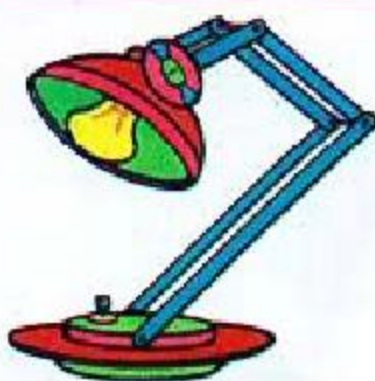

Encierra en un círculo los objetos que comienzan con el sonido inicial "M".



Colorea desde la salida hasta la llegada, el camino de los dibujos que comienzan con "P". Realiza lo mismo con el camino de la "M". Puedes ir en cualquier dirección.



Colorea los objetos que comiencen con "L" para que el león los pueda poner en su bolsa de palabras.



Colorea los objetos que comienzan con "J".
Escribe la letra "J" arriba de cada uno de ellos.

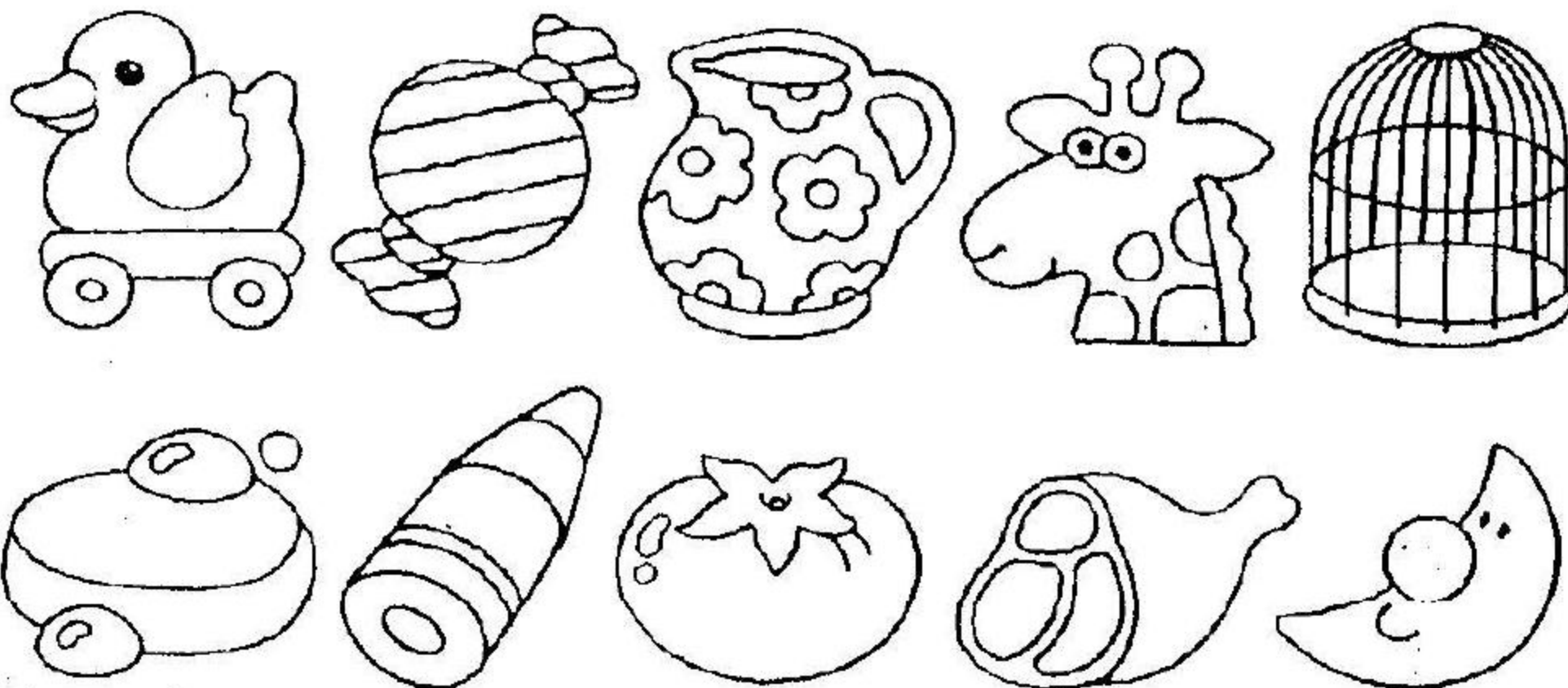

Marca con una cruz los dibujos que comiencen con "N"
Colorea las palabras que terminan con "N".

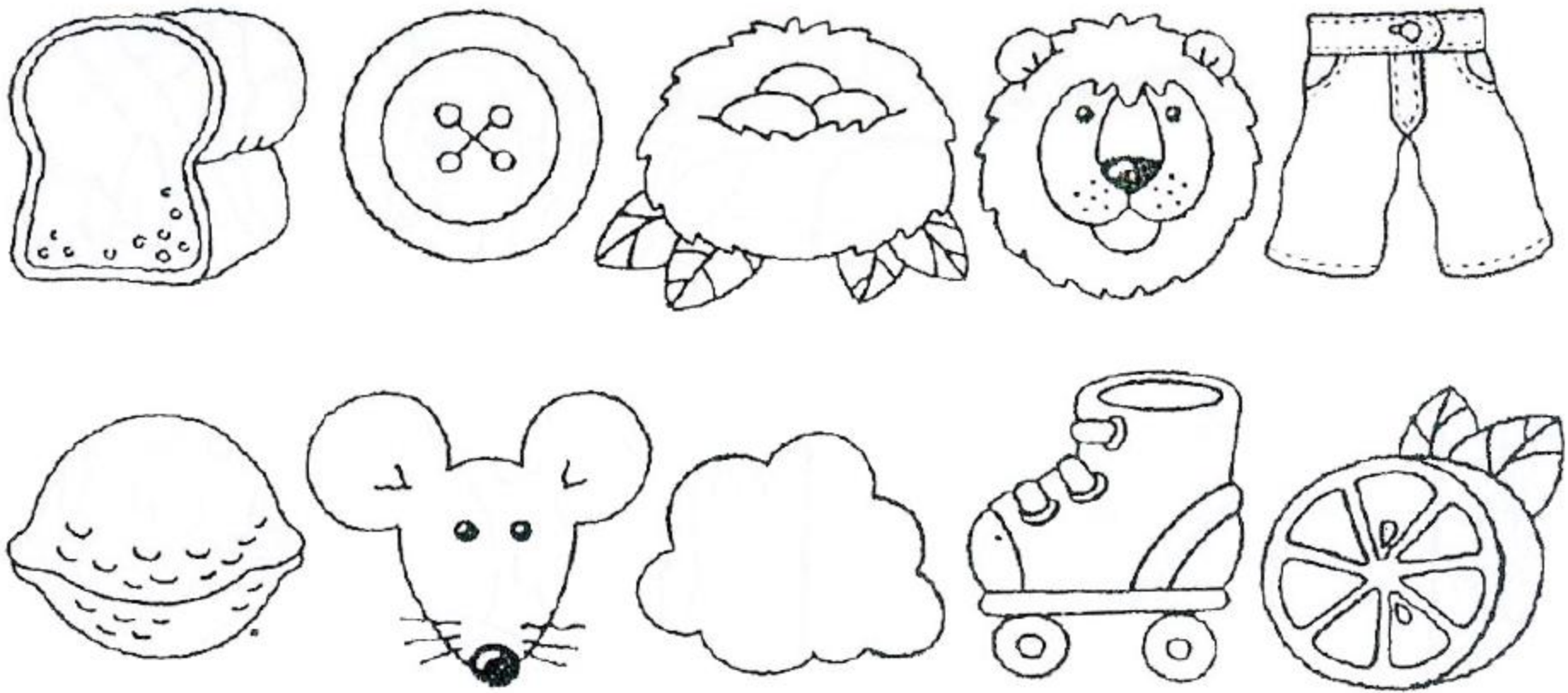

Colorea los elementos que comienzan con "F"
Escribe la letra arriba de cada uno de ellos.

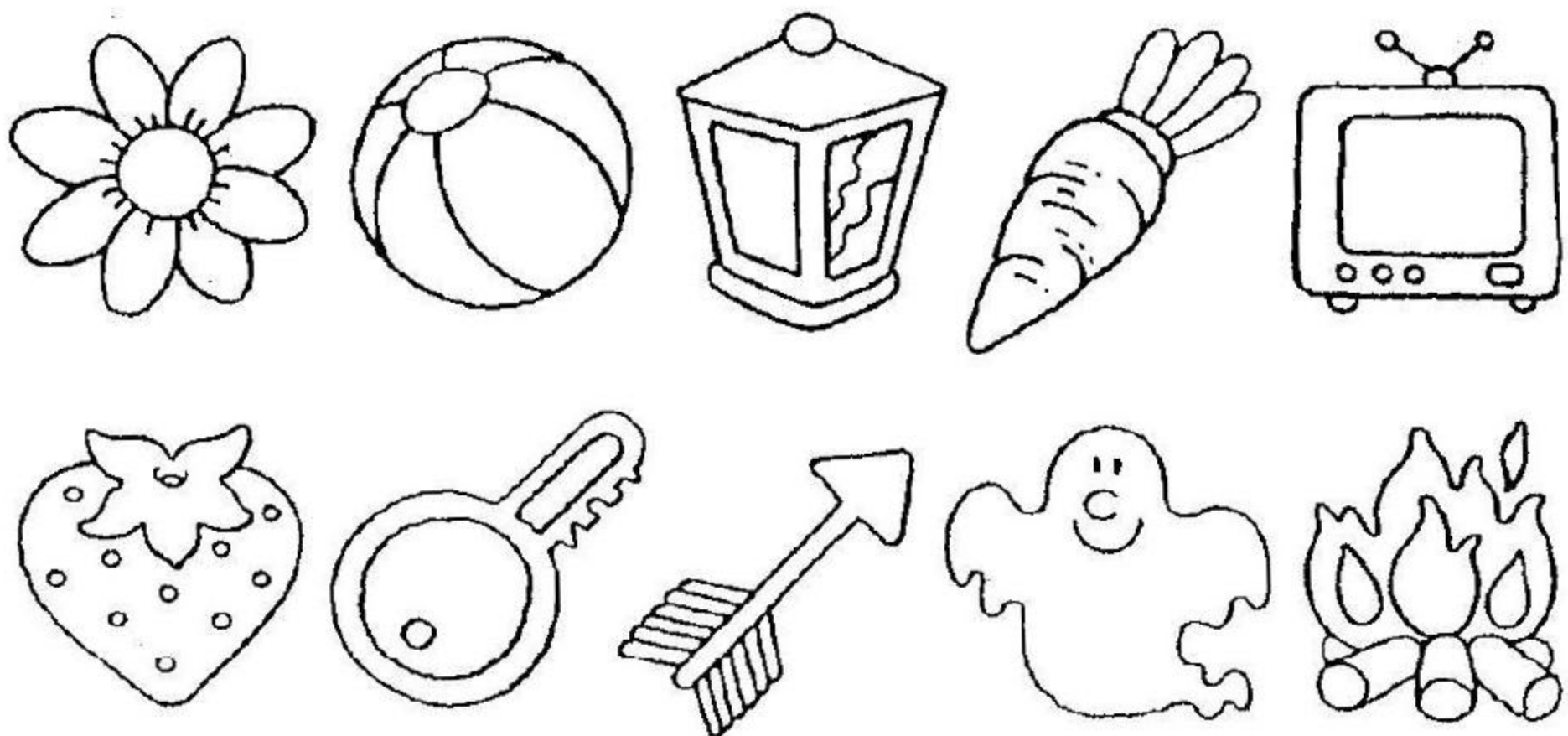

Colorea los dibujos que comiencen con "R".



Colorea los objetos que comiencen con "G"
Escribe la letra a la izquierda de cada uno de ellos.

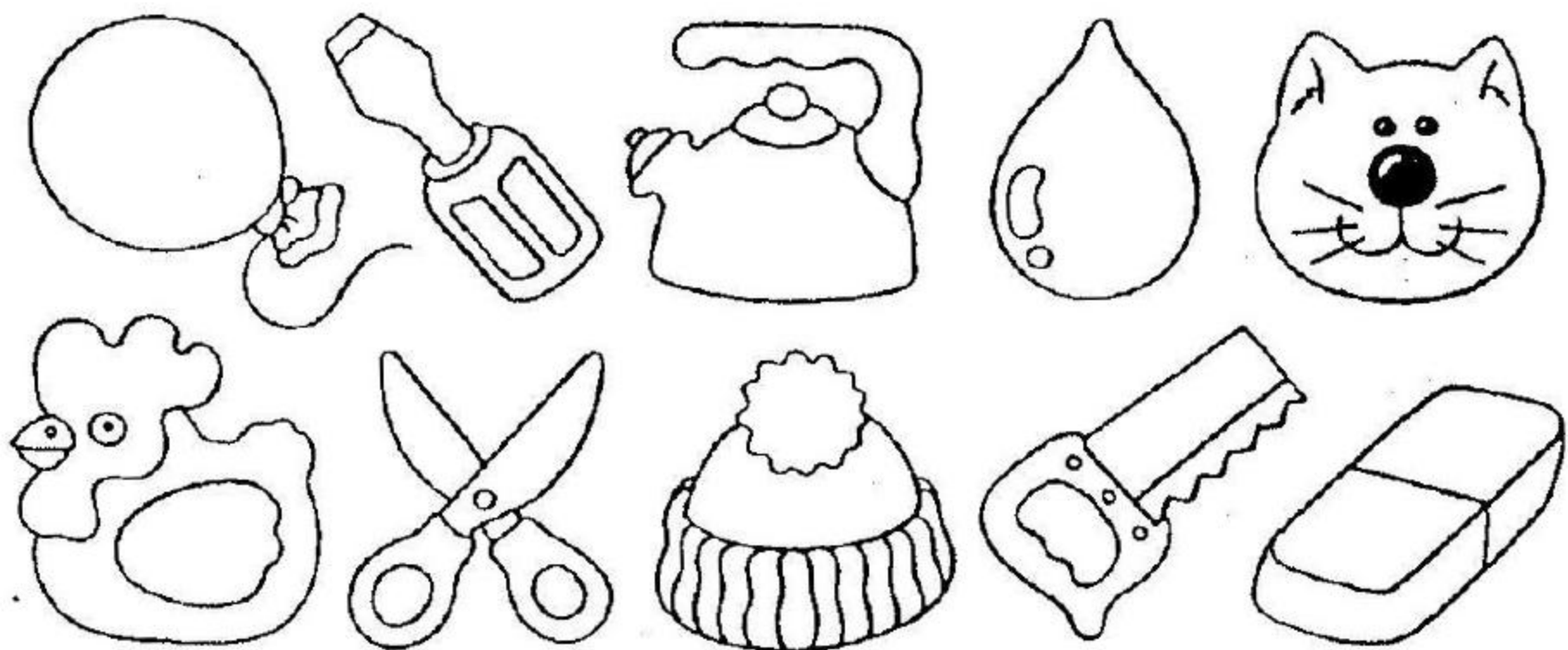

Observa la imagen y encuentra todas las palabras que comiencen con la letra "T". Píntalas.

Haz una cruz en cada recuadro por cada palabra que encuentres.

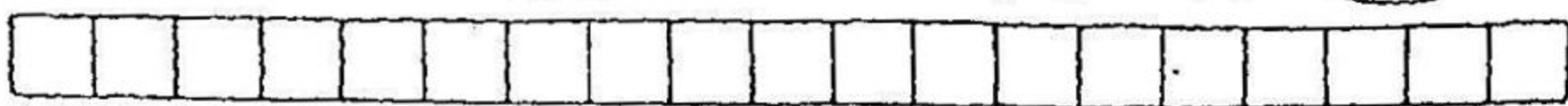

Nombra cada dibujo. Píntalo amarillo si comienza con "F" o celeste si comienza con "C."

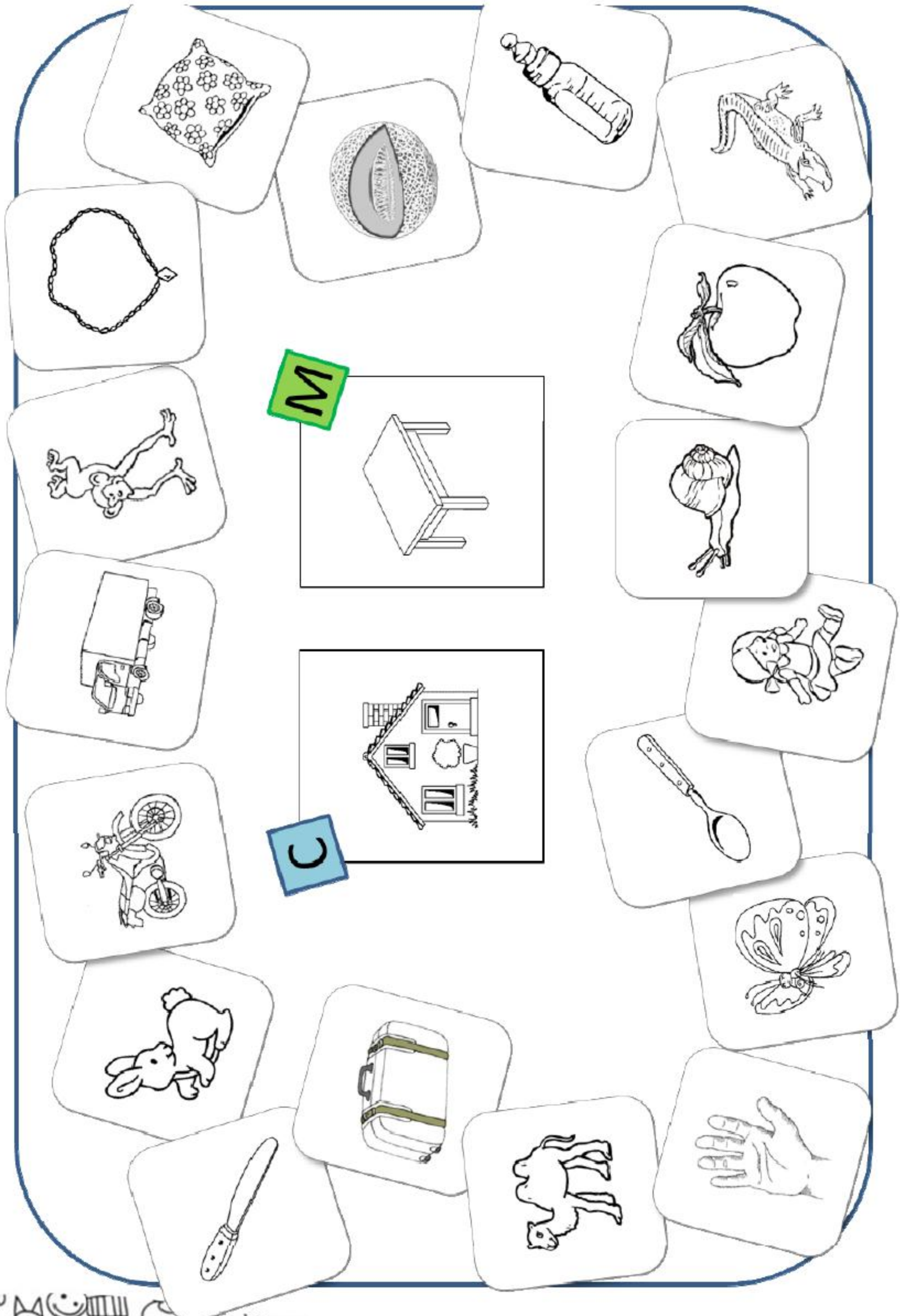







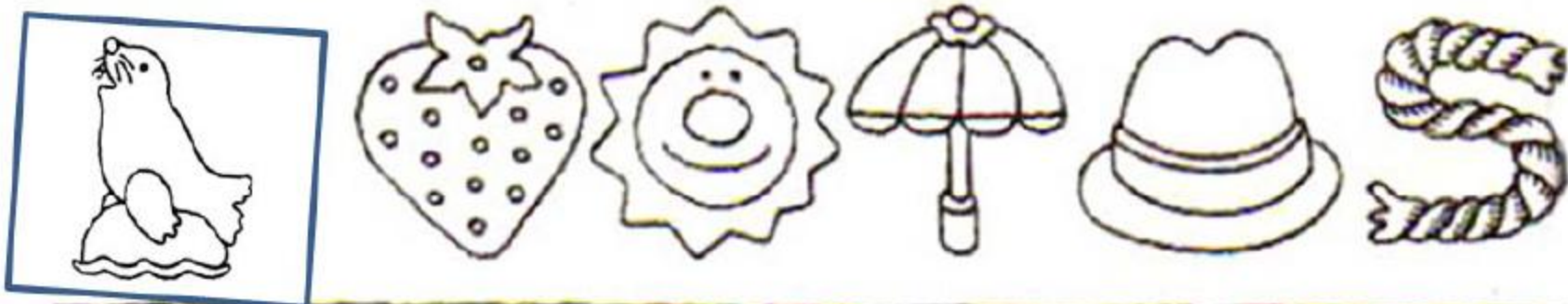
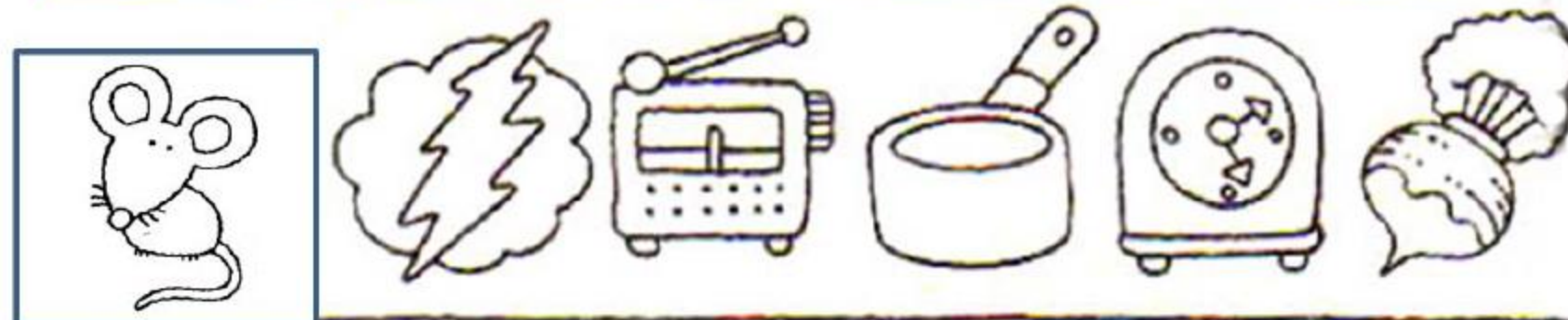
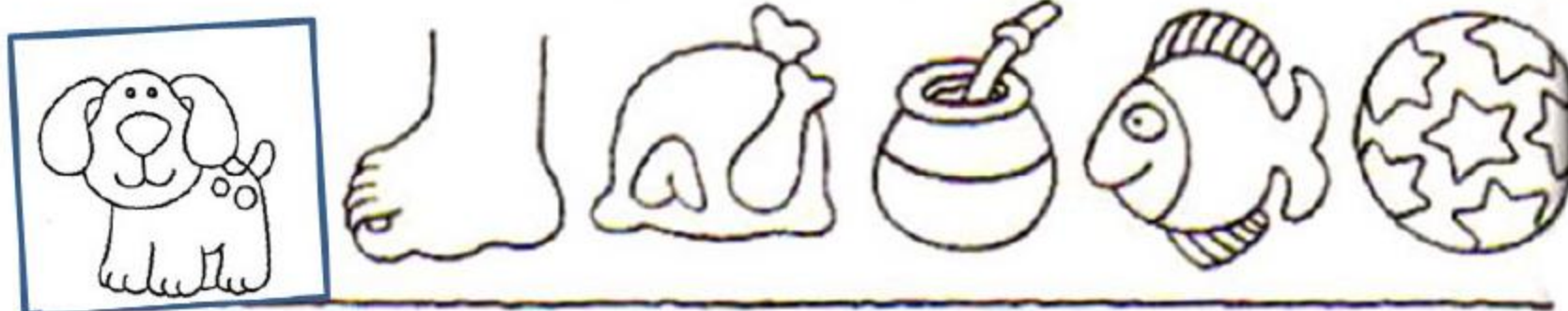
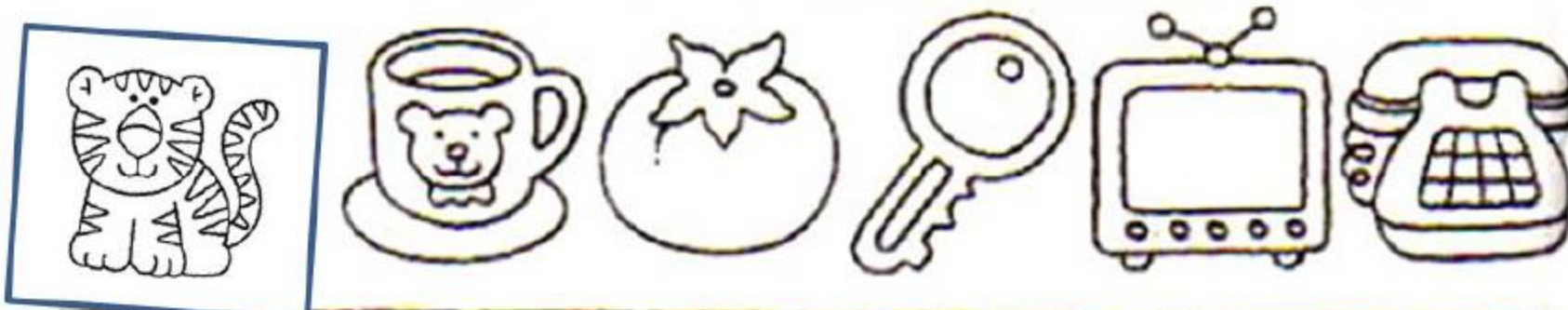











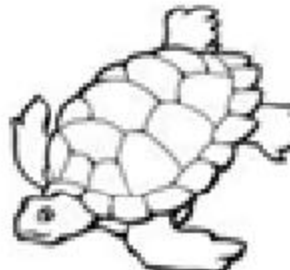

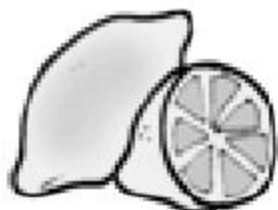

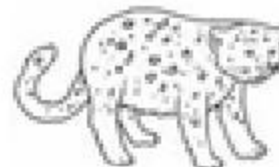





Nombra cada dibujo. Píntalo verde si comienza con "M" o celeste si comienza con "C."

A collection of 20 line drawings of various objects and animals, including a magnifying glass, a chair, a baby, a person with a suitcase, a hat, a palm tree, a stack of books, a strawberry, a rocking chair, an envelope, a basket, a watermelon, a sun, a bear, a fire, a boat, a lighthouse, and a bouquet of flowers. Two letters are highlighted: 'F' in a yellow box and 'S' in a blue box.

Nombra cada objeto en voz alta y colorea los que comienzan igual que la palabra modelo.

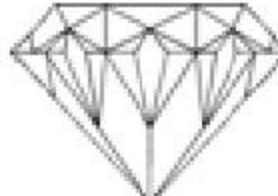

Colorea los dibujos que comienzan con el mismo sonido que el de la izquierda.

				
				
				
				
				
				

Une los objetos que comienzan con el mismo sonido.

Antonia Fernández Profesora Especialista en Lenguaje

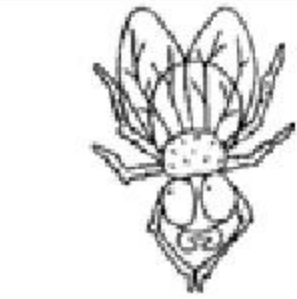

Encierra en un círculo las parejas de palabras que terminen con el mismo fonema y tacha las que terminan diferente.

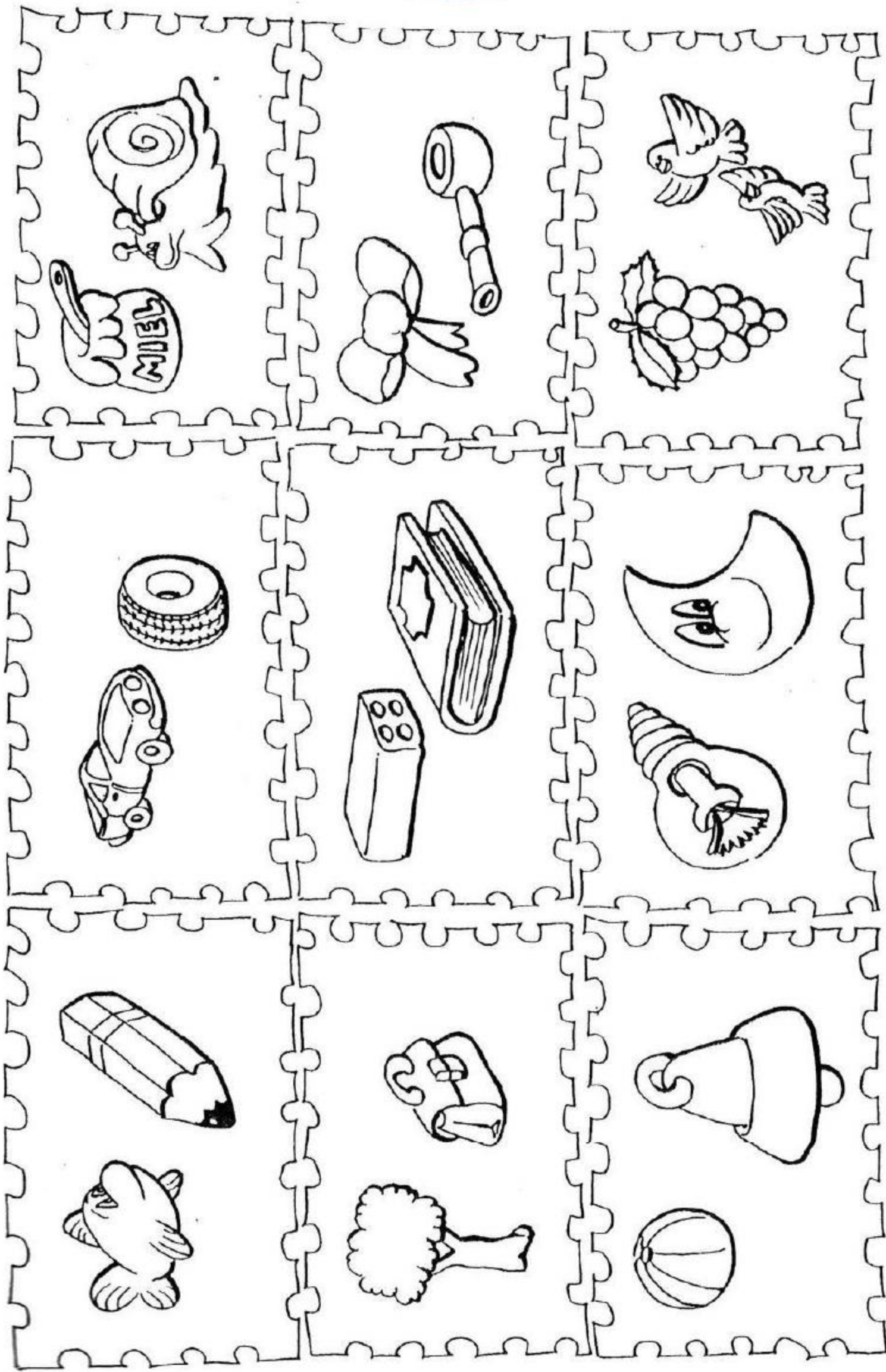

Estímulos: Pez- lápiz; auto- rueda; miel- caracol; árbol- bolso; ladrillo- libro; lazo- pipa; pelota- campana; bombilla- luna; uvas- pájaros

Pronuncia el nombre de los dibujos, alargando el sonido final. En cada serie hay un dibujo cuyo nombre no termina igual que los demás, táchalo. Colorea los que terminan igual.

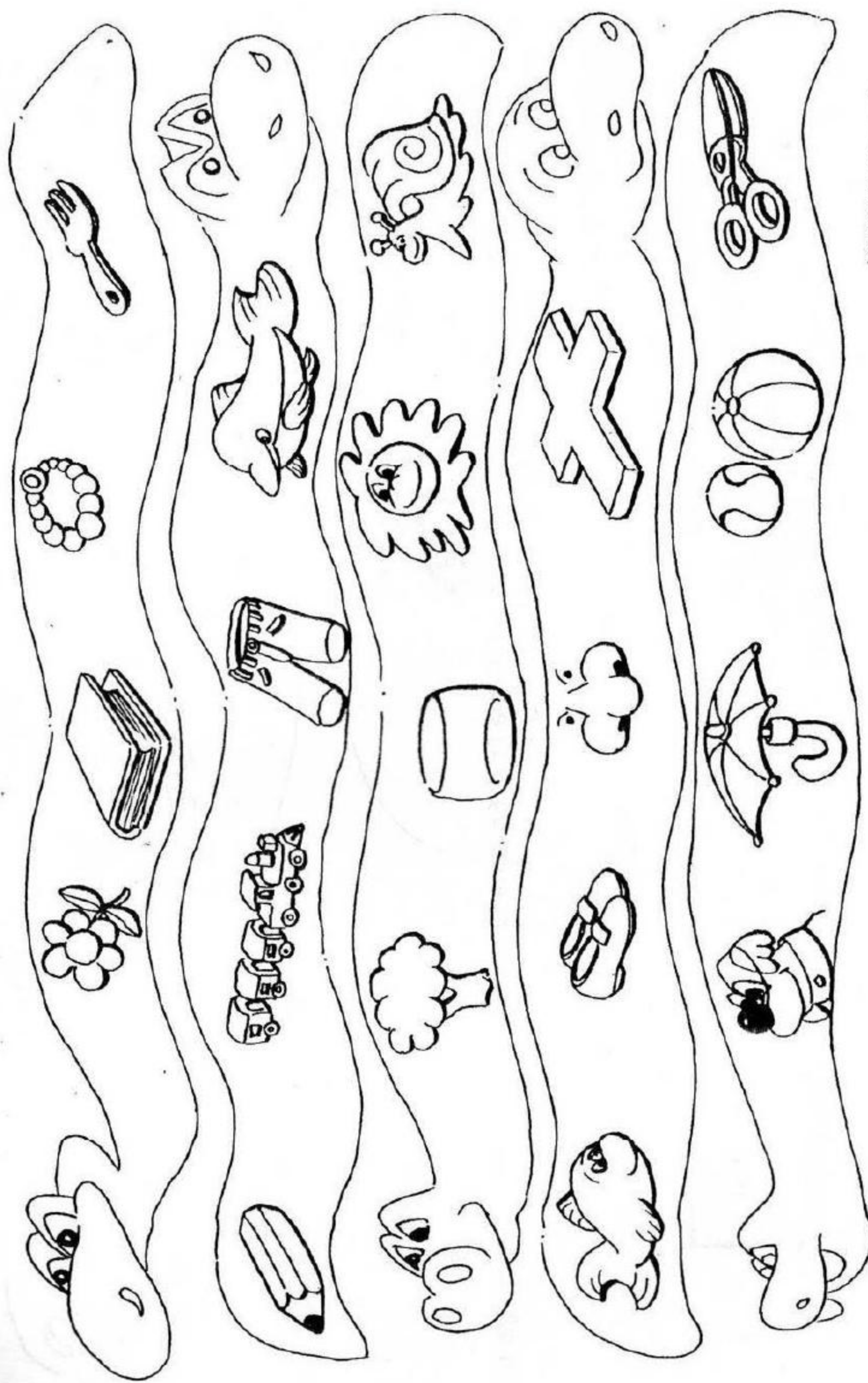

Actividad complementaria: Decir una palabra y pedir que los niños busquen otra que termine con el mismo fonema.

Estímulos: Flor-libro-collar-tenedor; lápiz-tren, -pantalón-delfín; árbol-vaso-sol-caracol; pez-zapatos-nariz-cruz; payaso-paraguas-pelotas-tijeras

Encierra los juguetes que tienen el sonido "S".



Encierra en un círculo los dibujos que en su nombre tengan el sonido "L".



Encierra en un círculo verde los dibujos que contienen el sonido "B".

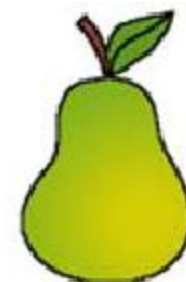
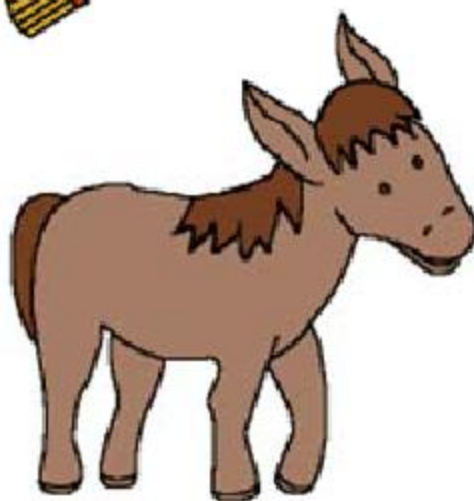
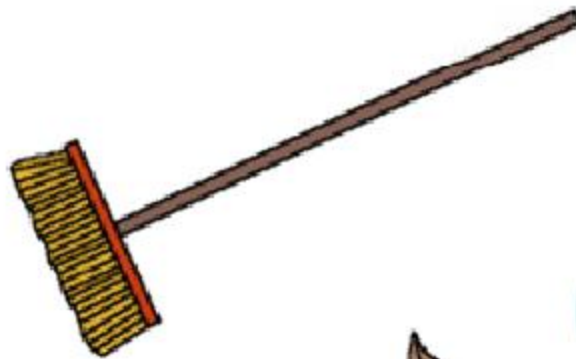
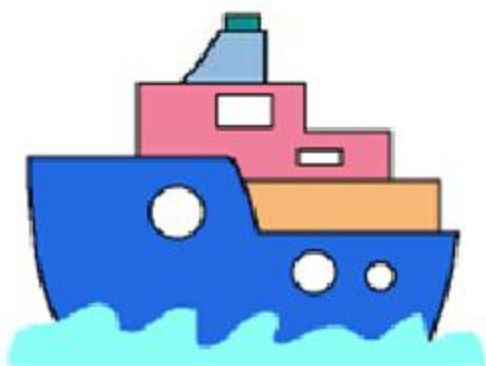

Encierra en un círculo los dibujos que tienen el sonido "F" en su nombre.

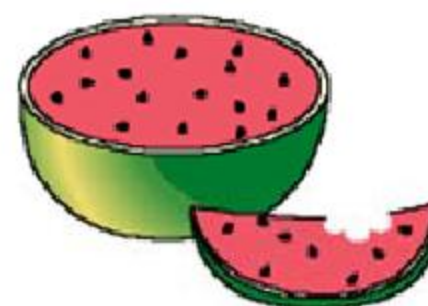

Encierra en un círculo los dibujos que tienen el sonido "RR".

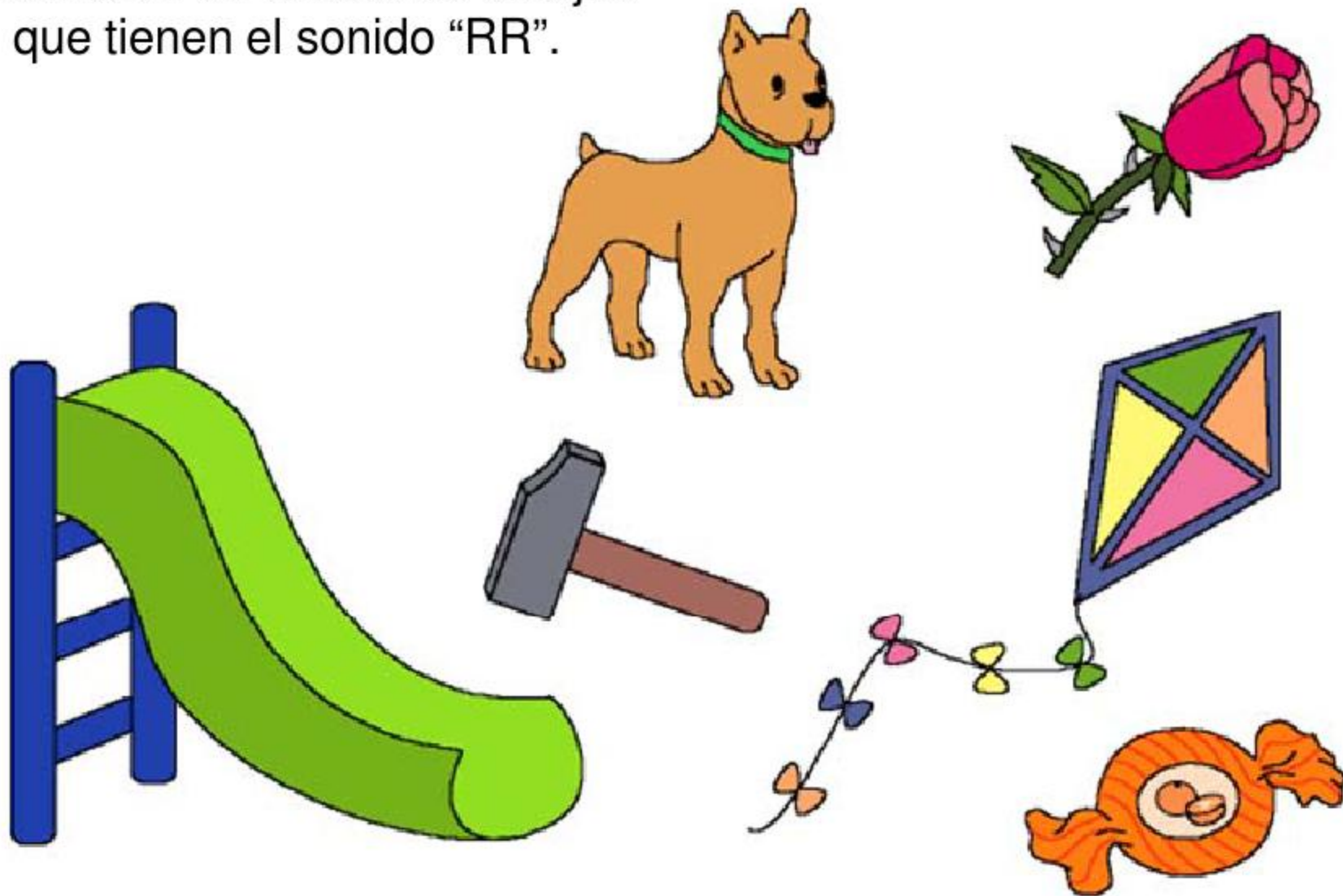

Encierra en un círculo los animales que en su nombre contengan la letra "G".



Encierra los dibujos que contienen el sonido "N".



Encierra en un círculo los dibujos que contienen el sonido "D".



Encuentra la palabra escondida y únela. Para ello debes descubrir el primer sonido de cada dibujo y juntarlos con la vocal.

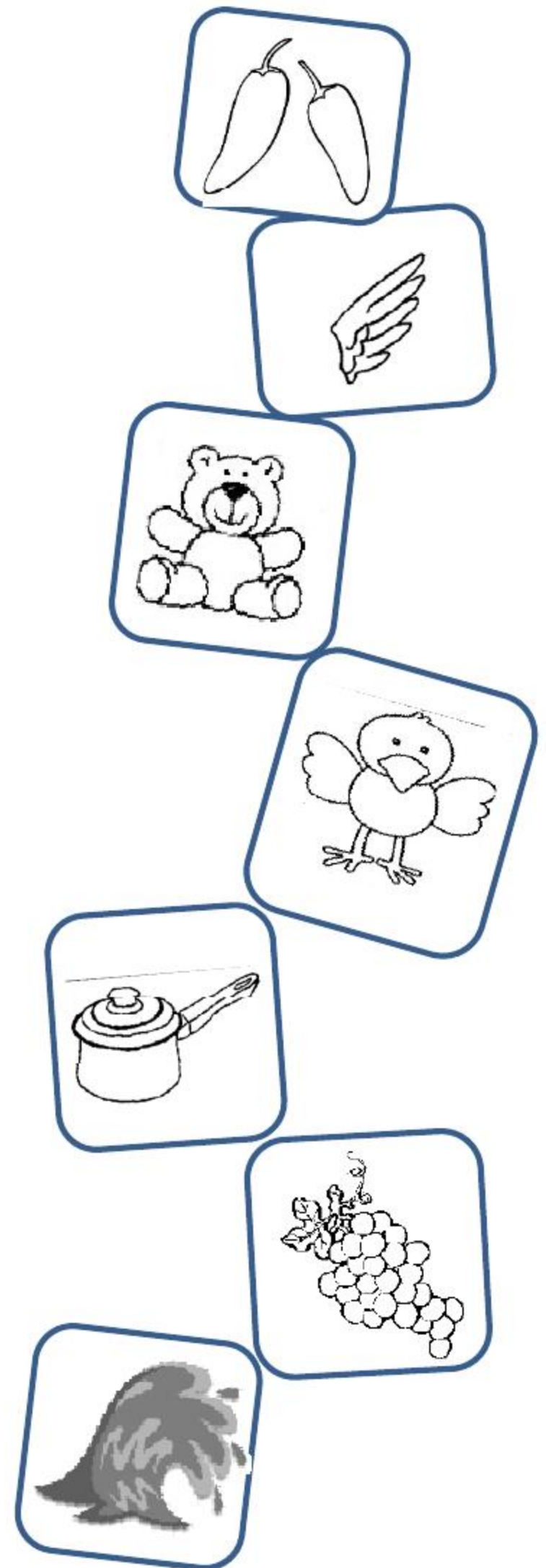
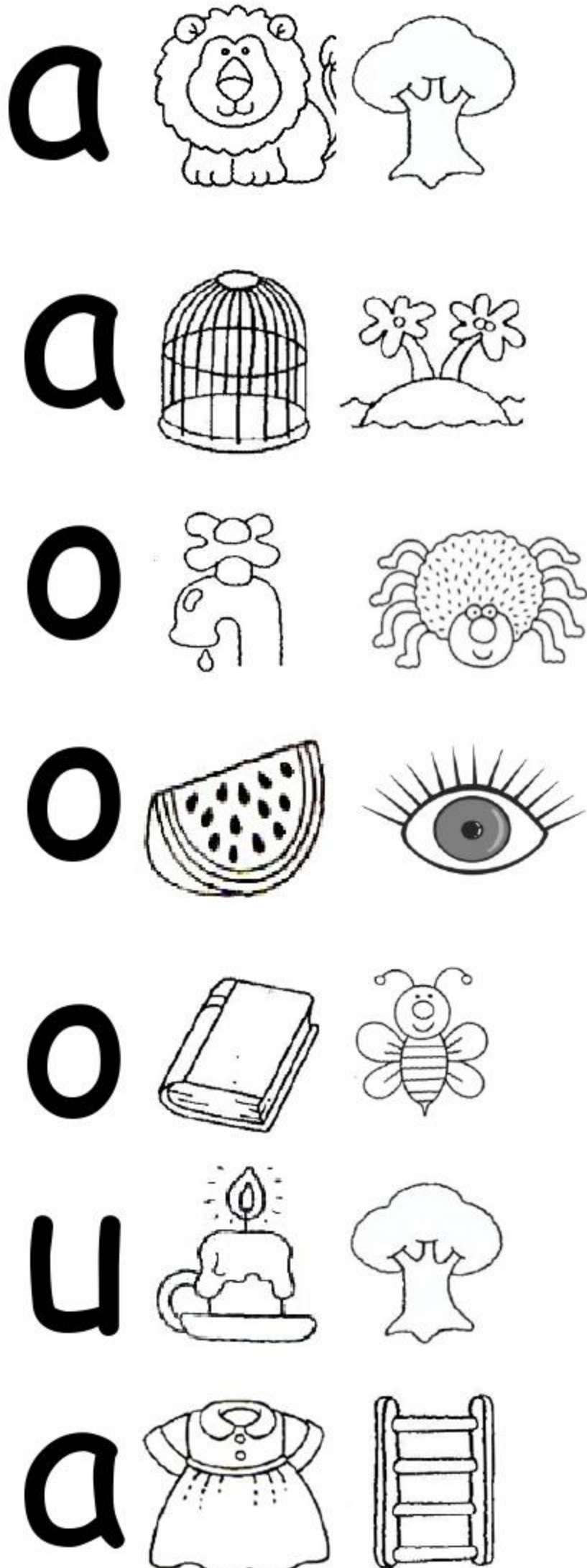

Junta el primer sonido de cada dibujo y nombra la sílaba que se forma.
Únela al dibujo que comience con esa sílaba.

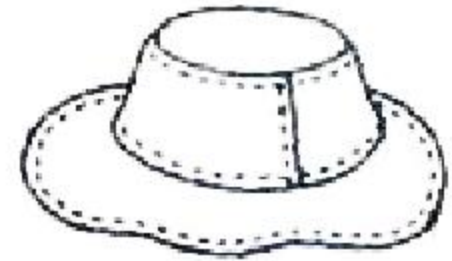
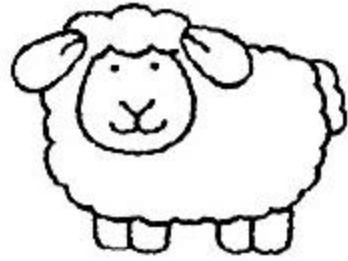
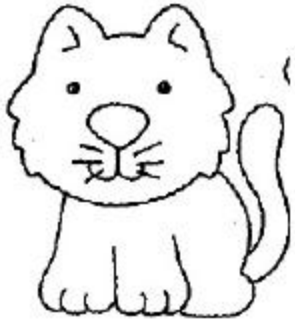



Junta el sonido inicial de cada dibujo y descubre la palabra secreta, luego dibújala.

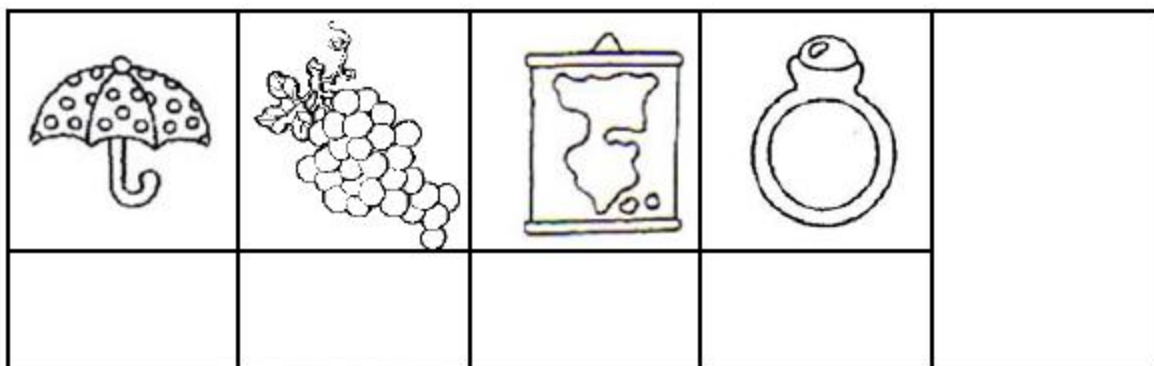
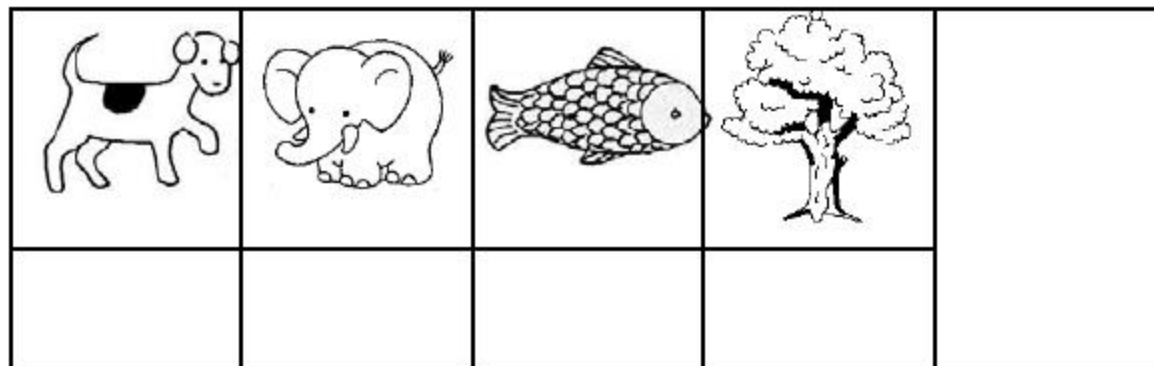
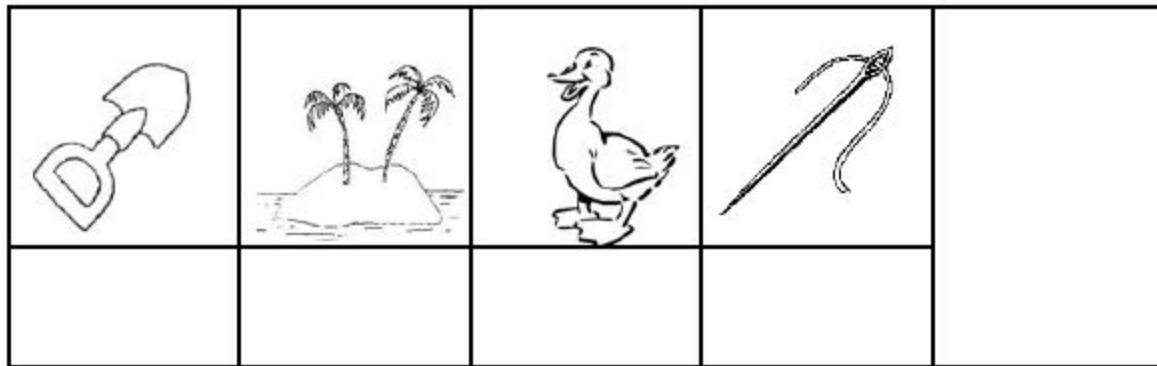
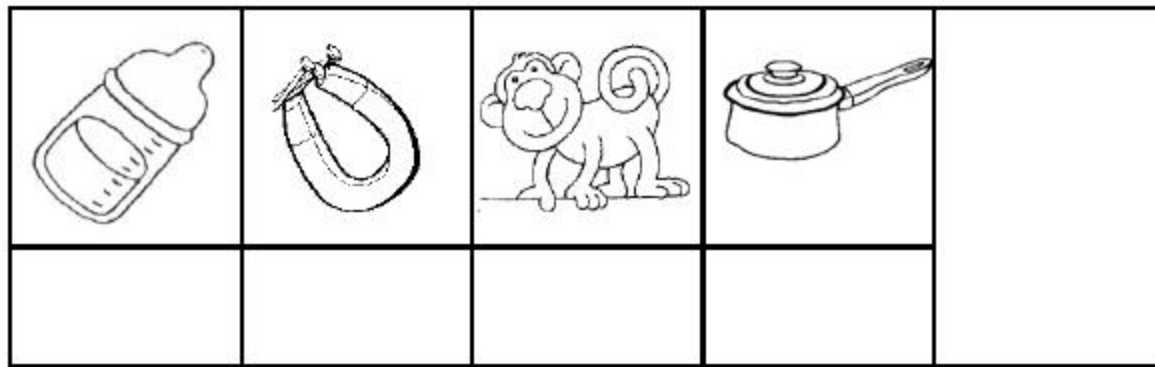
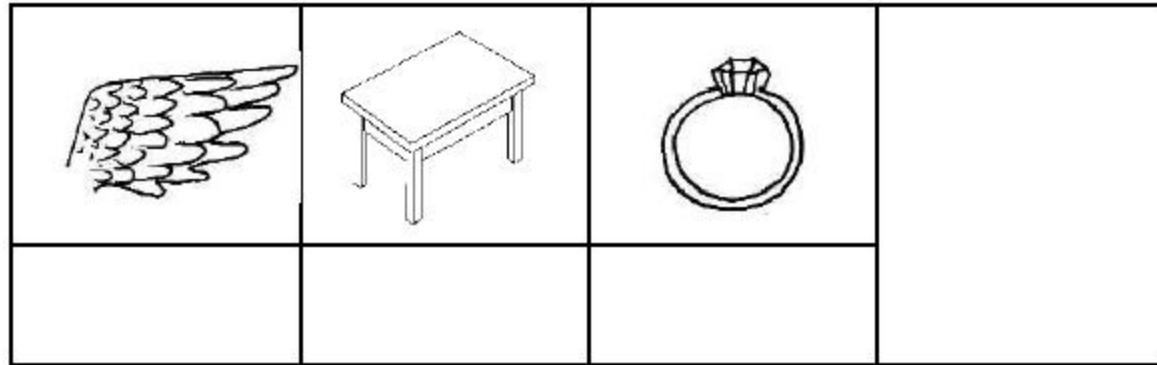

Catherine Álvarez. Profesora Especialista en Lenguaje

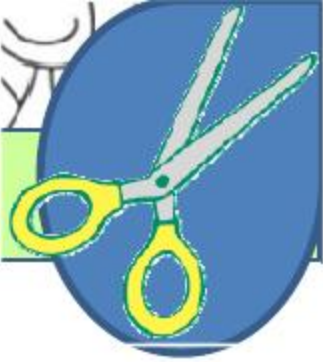

Nombra el objeto. Di los sonidos que forman la palabra. Busca estos sonidos en las figuras 92 pensando en el sonido inicial de cada una. Pega las figuras en orden hasta formar la palabra presentada.

Ejemplo:

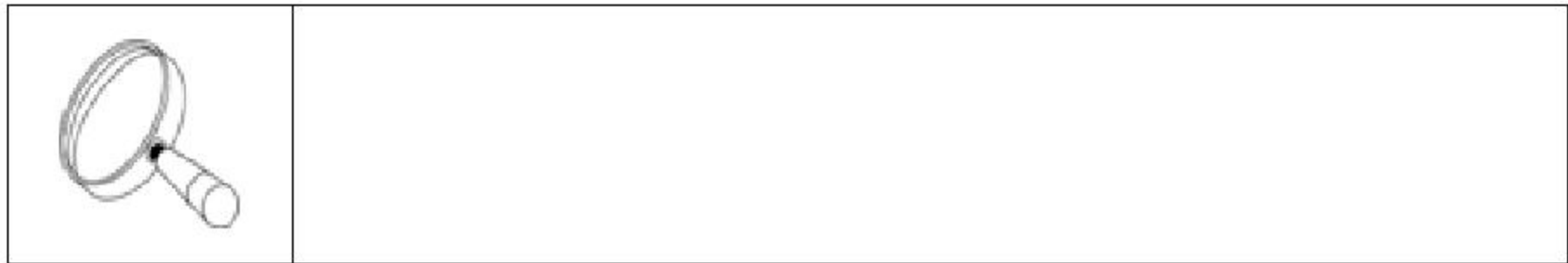
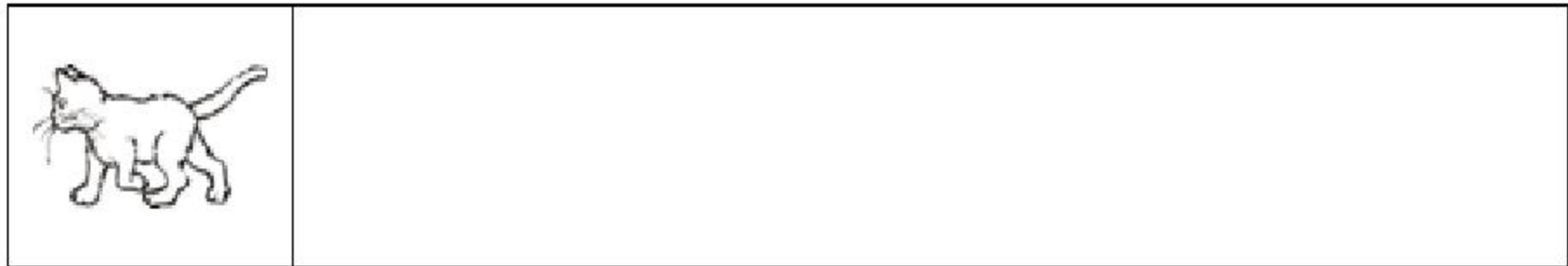
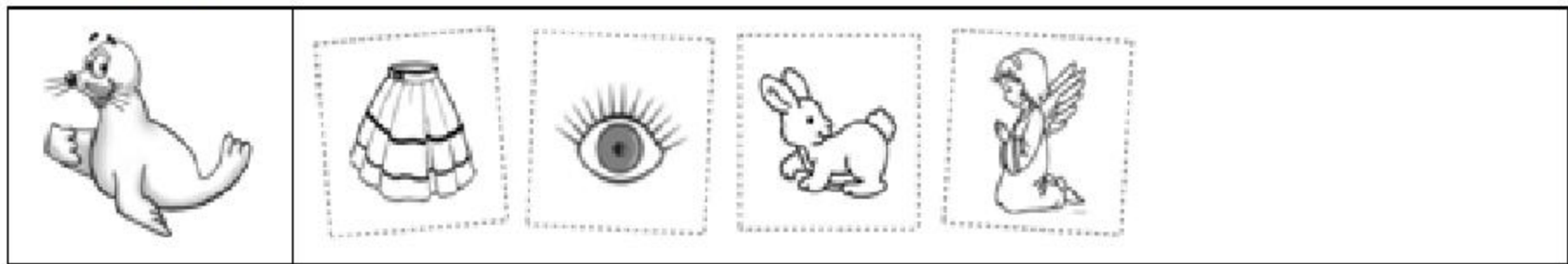





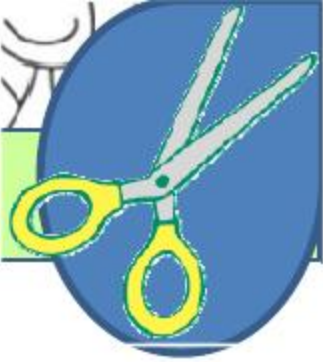



Identifica el primer sonido de cada dibujo, descubre qué palabra forman y únelo con una línea.



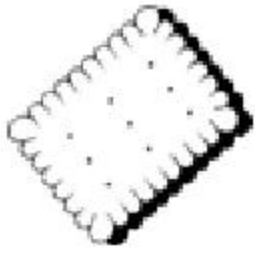

Nombra el objeto. Di los sonidos que forman la palabra. Busca estos sonidos en las figuras de la página 92 pensando en el sonido inicial de cada una. Pega las figuras en orden hasta formar la palabra presentada.

Identifica el primer sonido de cada dibujo, descubre qué palabra forman y únelo con una línea.



Identifica el primer sonido de cada dibujo, descubre qué palabra forman y únala con una línea.



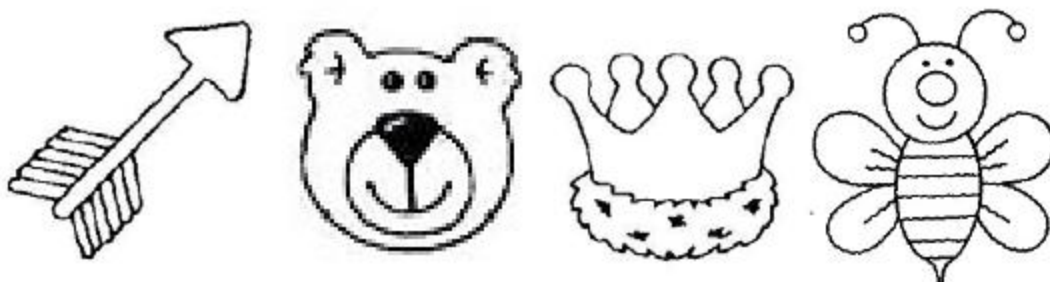
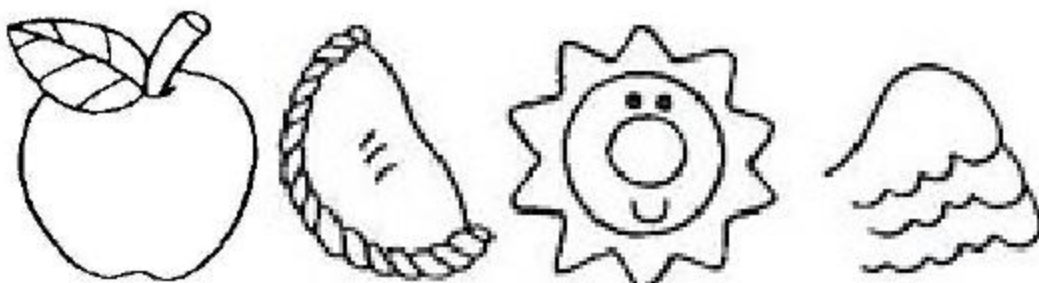
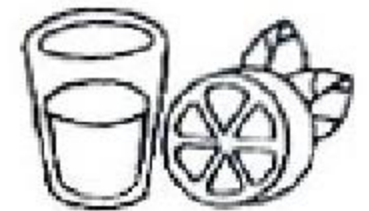
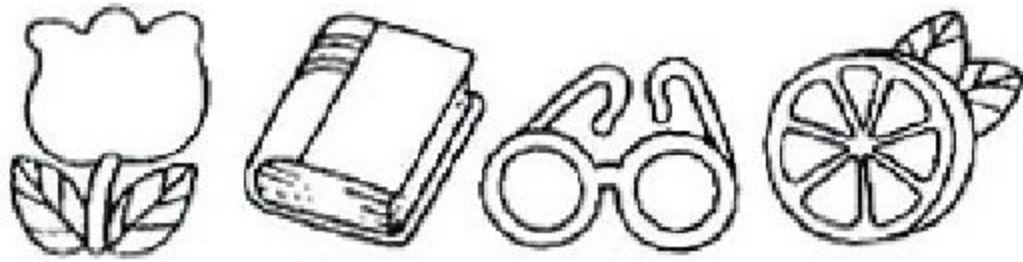

Recorta las imágenes y pégalas en los espacios según el número de sílabas de cada una (1, 2, 3 ó 4 sílabas).



Recorta los dibujos y pega cada uno según su sílaba inicial.

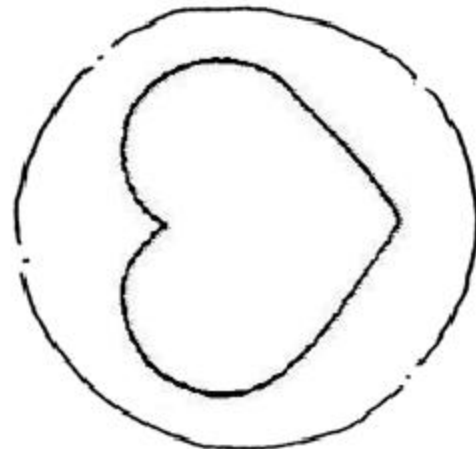
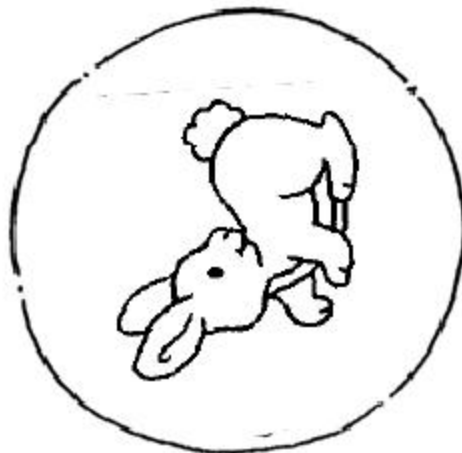
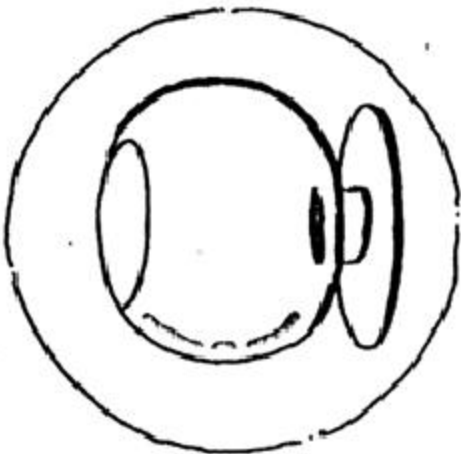
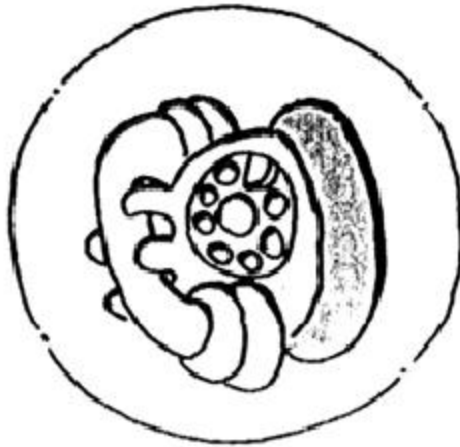
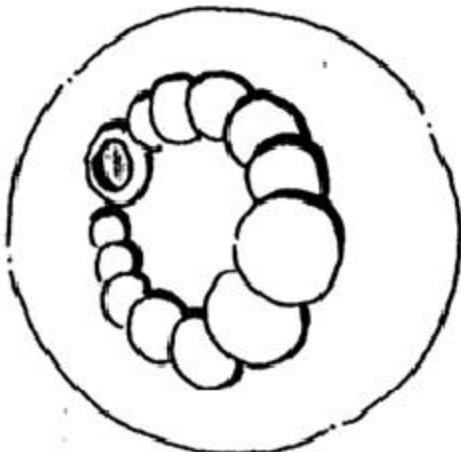
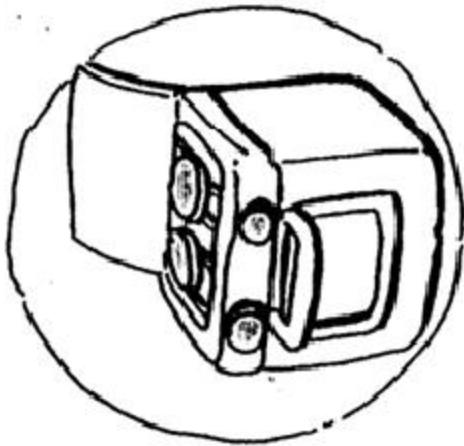
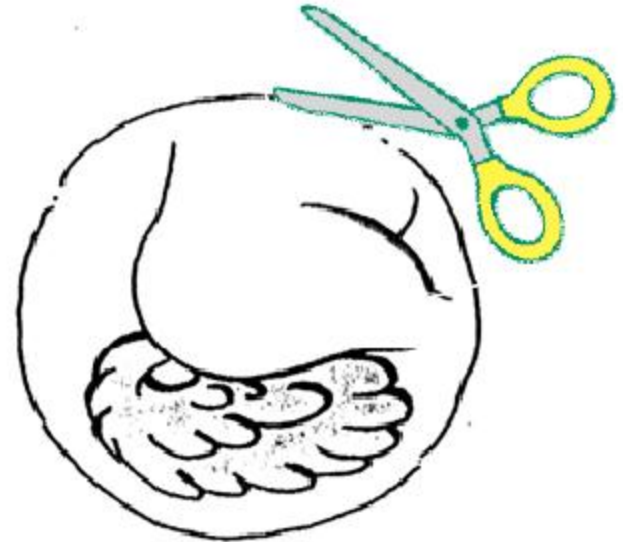











Recorta las figuras y pega cada elemento que completa la oración con el mismo sonido final.











Actividad 2 de Rima.



Actividad 1 de Rima.

		
		
		



Recorta cada dibujo y pégalos hacia abajo según corresponda cada vocal.

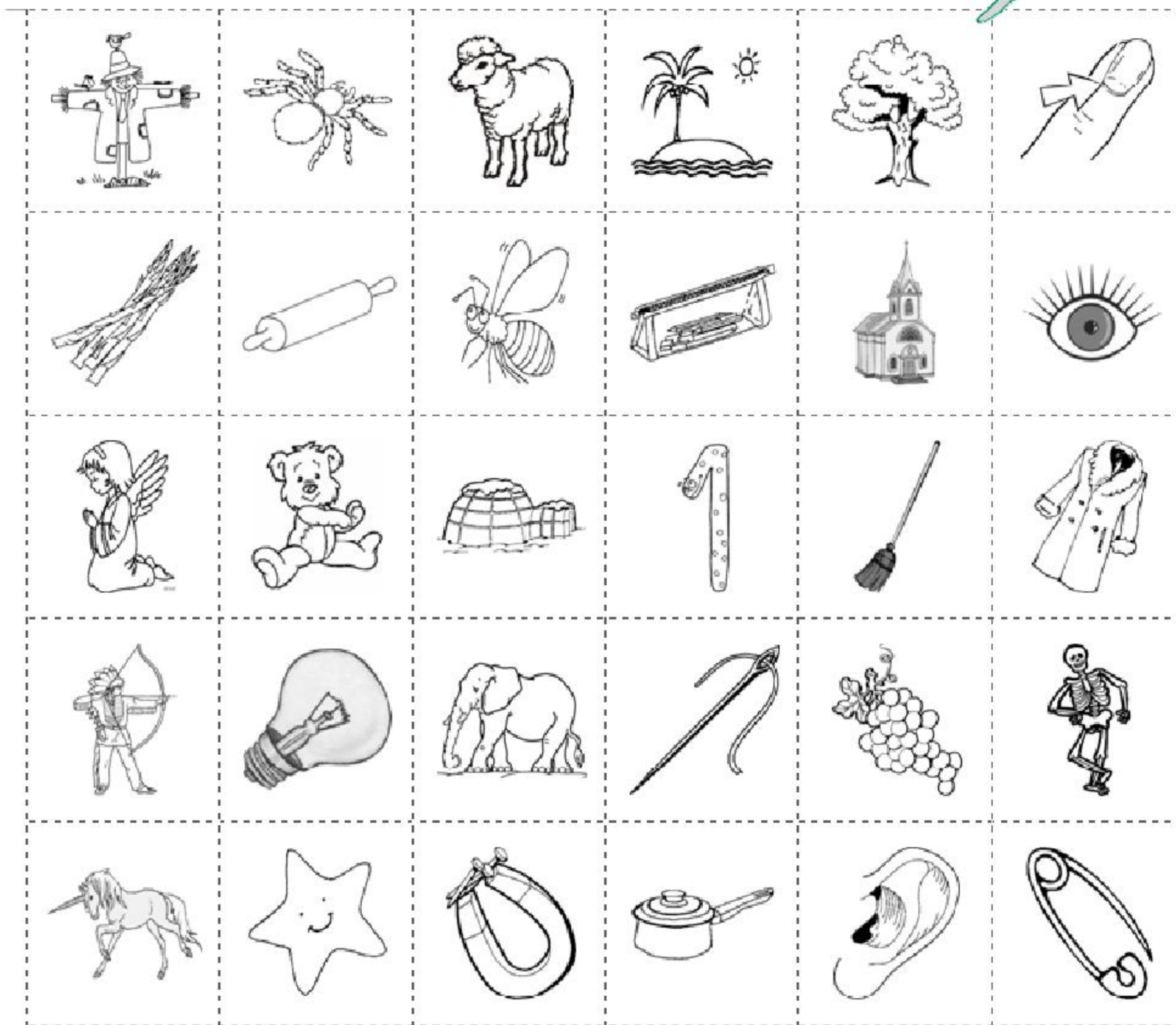
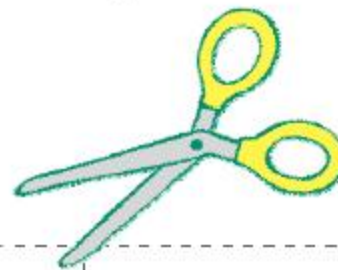

Recorta los dibujos y forma las palabras de la página 82.

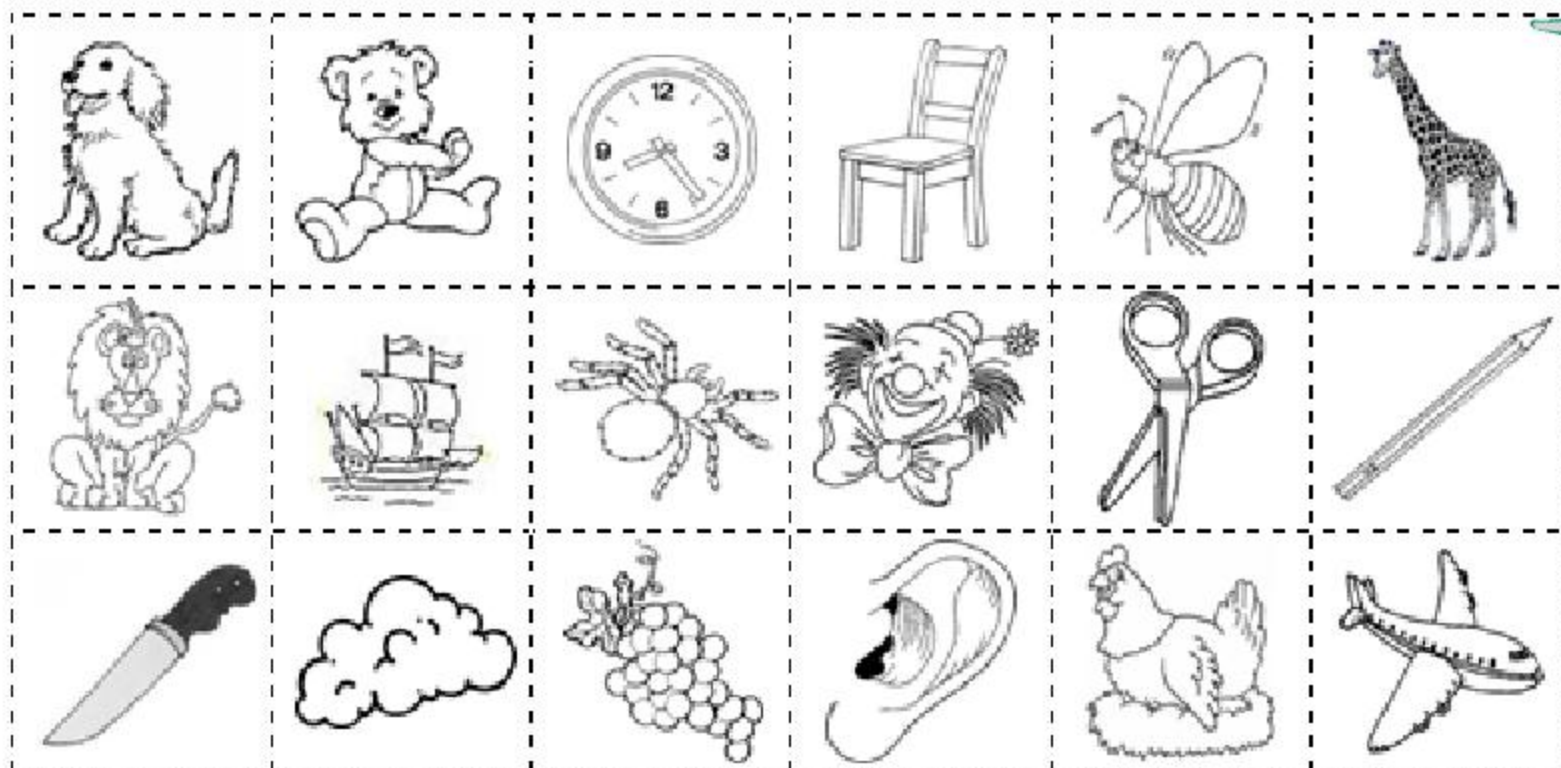

Recorta los dibujos y forma las palabras de la página 84.

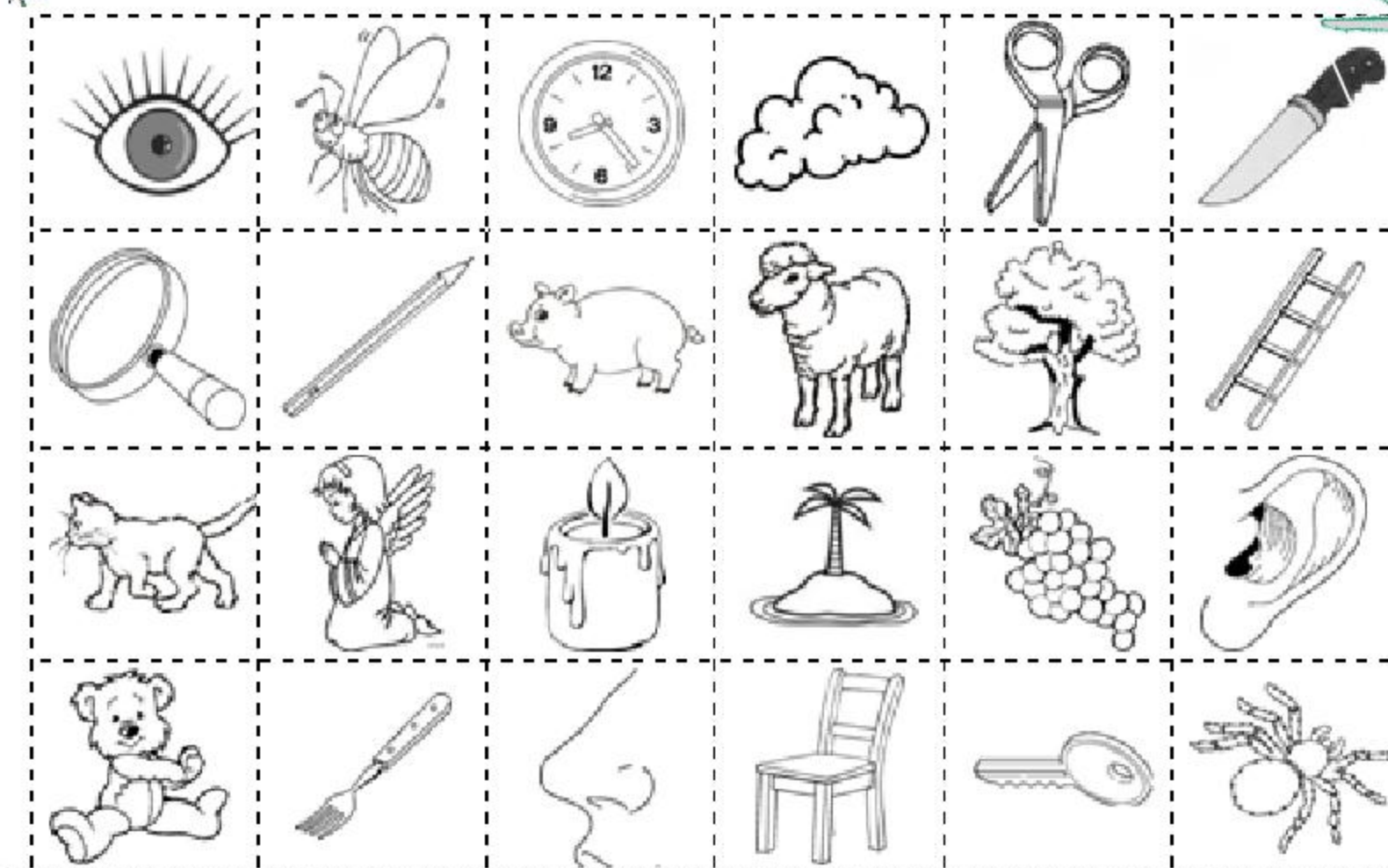



BIBLIOGRAFÍA

1. Discriminación Fonética y Fonológica. Inés Bustos Sánchez. 2001
2. Hurganito: Ejercicios de lectura y escritura. Mabel Condemarín. Editorial Universitaria
3. El lápiz que habla
4. Semilla: Kinder, iniciación a la Lectura y Escritura. Editorial Santillana
5. Mejorando el lenguaje. Coca Muñoz et al. Editorial Libart. 2004
6. Jugando Aprendo
7. Letramanía 1: La imprenta Mayúscula. Sally Johnson y Sara Inés Gómez Carrillo
8. Letramanía 2: Jugamos con las Mayúsculas. Sally Johnson y Sara Inés Gómez Carrillo
9. Letramanía 3: La letra cursiva. Sally Johnson y Sara Inés Gómez Carrillo
10. Letramanía 4: Jugamos y escribimos en cursivas. Sally Johnson y Sara Inés Gómez Carrillo

Agradecemos muy especialmente a Camila Salas, quien con mucho amor y dedicación nos diseñó las hermosas portadas.