

Actividades para mejorar motricidad fina

Sigue los huevos para unir la gallina y el pollito

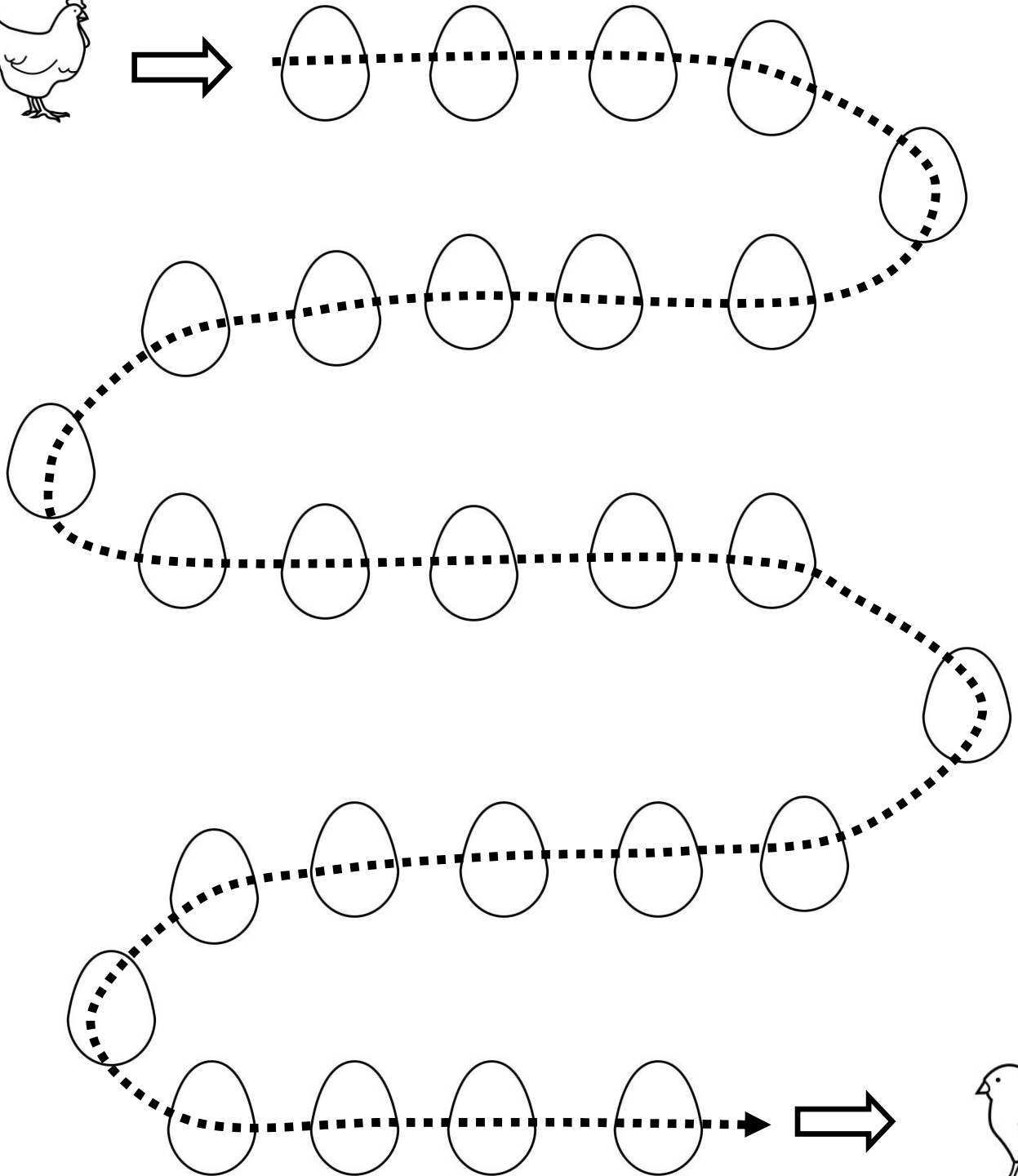
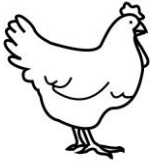

# Actividades para mejorar motricidad fina

Sigue los huevos para unir la gallina y el pollito

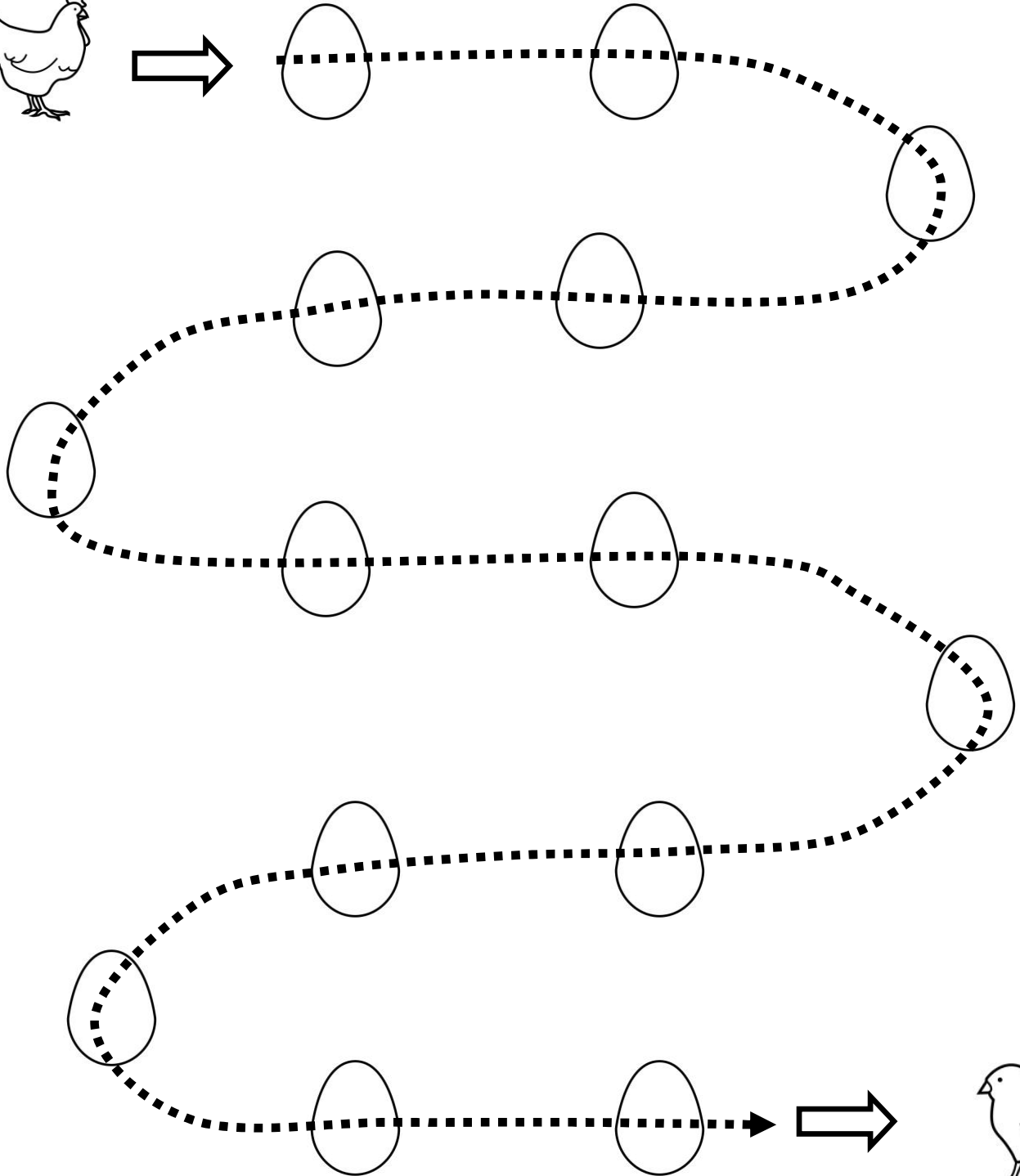
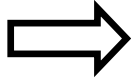
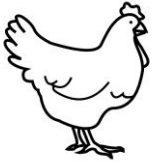

# Actividades para mejorar motricidad fina

Sigue los huevos para unir la gallina y el pollito

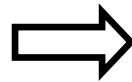
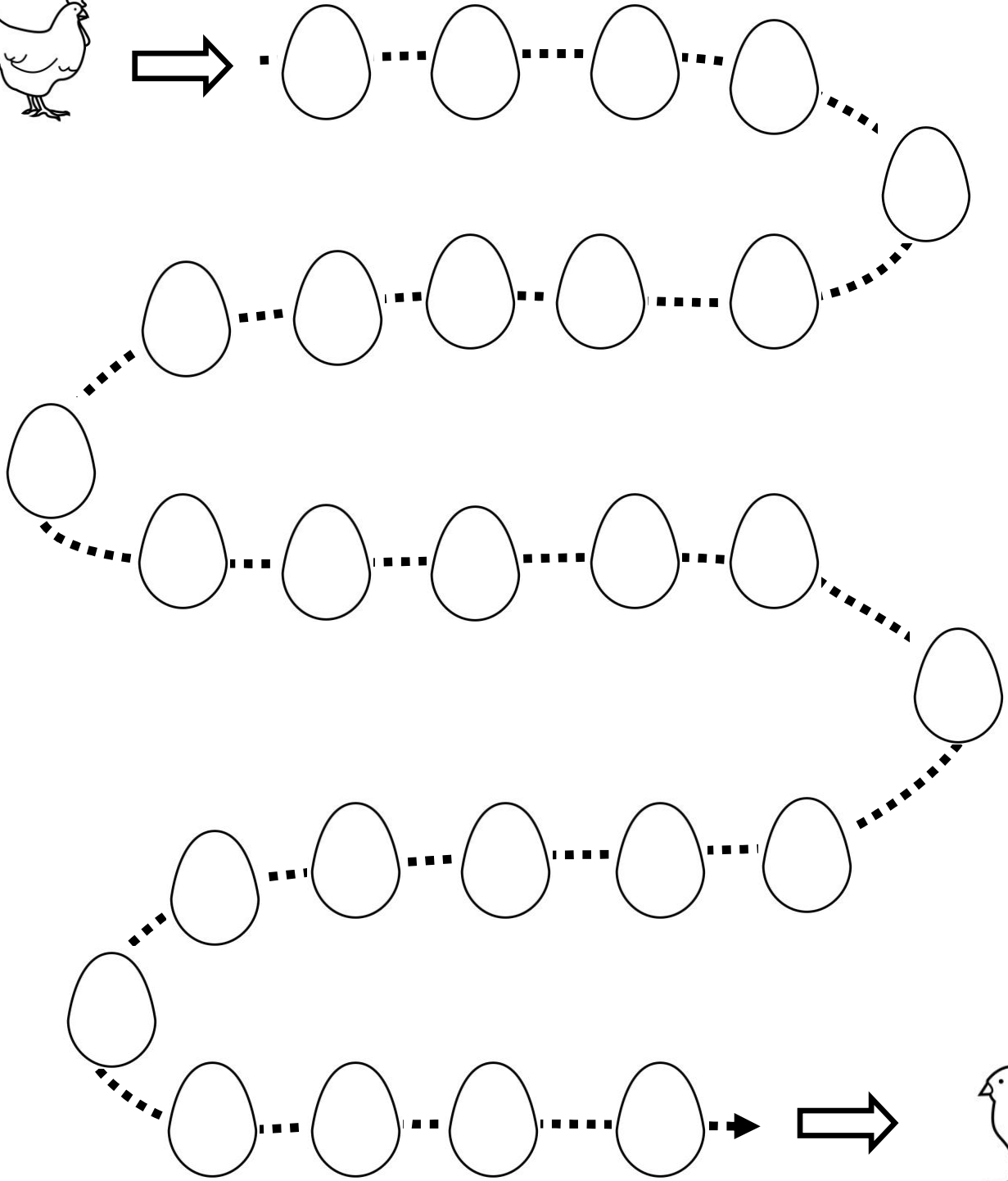
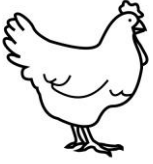

# Actividades para mejorar motricidad fina

Sigue los huevos para unir la gallina y el pollito

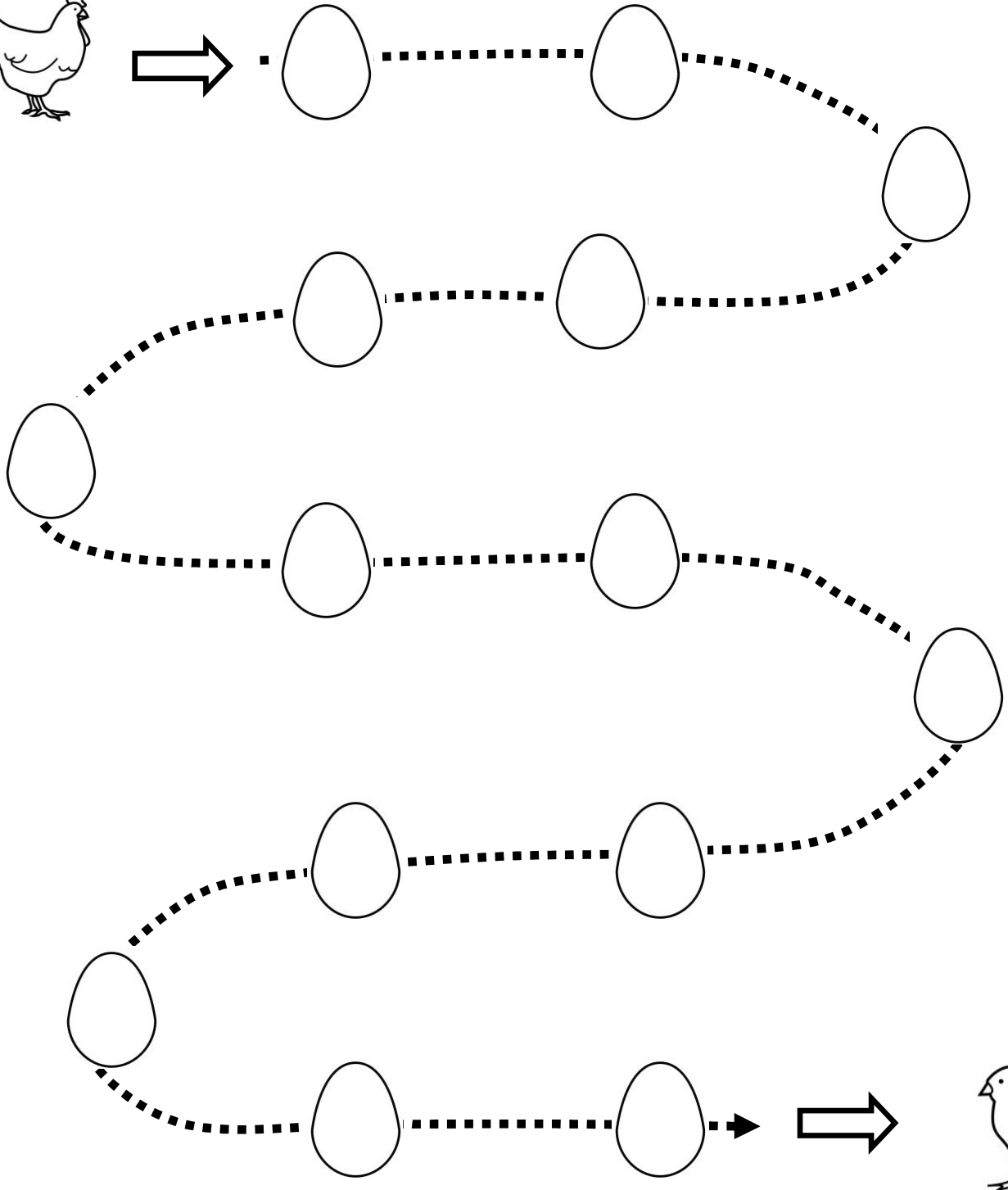
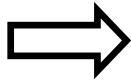
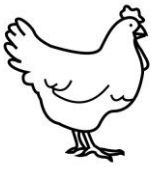

# Actividades para mejorar motricidad fina

Sigue los huevos para unir la gallina y el pollito

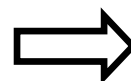
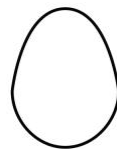
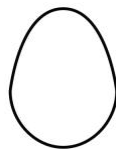
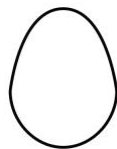
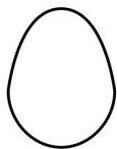
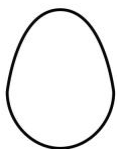
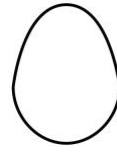
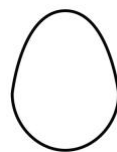
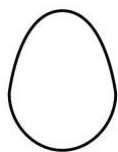
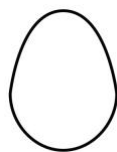
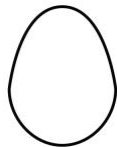
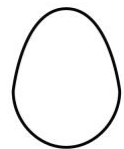
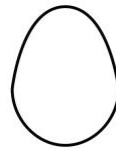
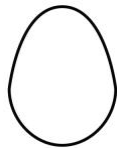
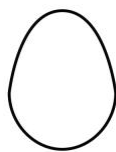
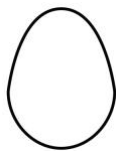
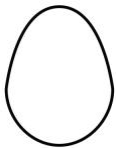
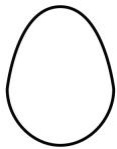
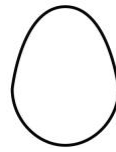
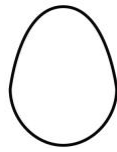
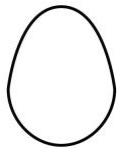
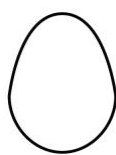
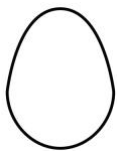
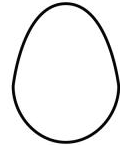
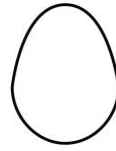
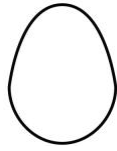
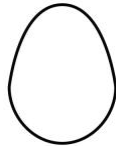
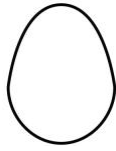
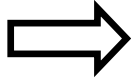
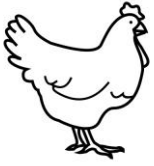

# Actividades para mejorar motricidad fina

Sigue los huevos para unir la gallina y el pollito

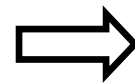
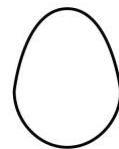
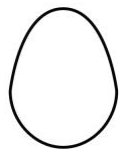
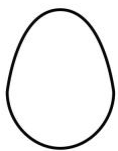
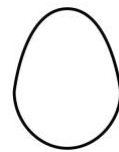
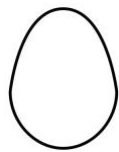
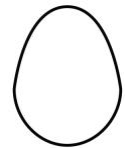
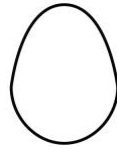
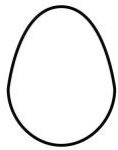
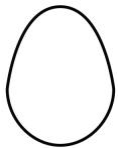
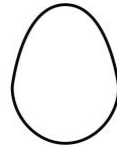
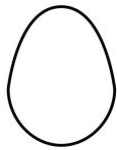
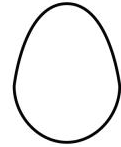
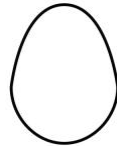
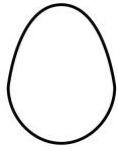
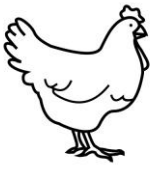



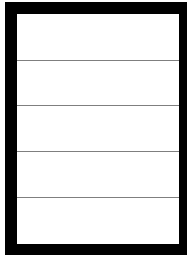

## Grafomotricidad formas y cenefas

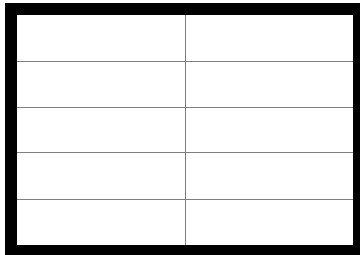

										
										
										



## Grafomotricidad formas y cenefas

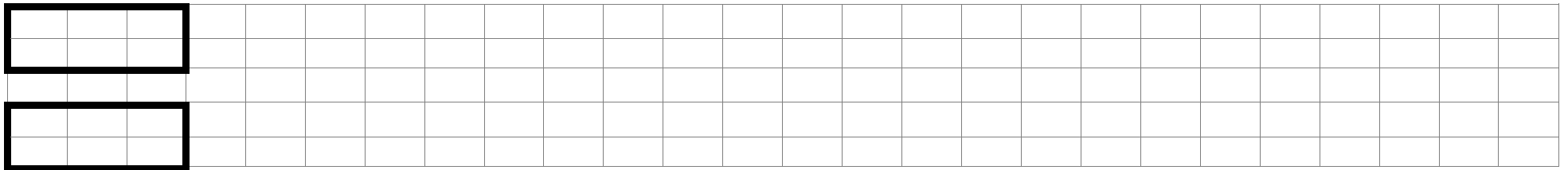
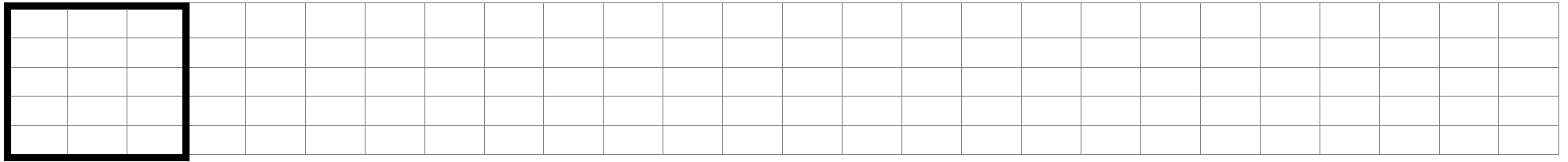
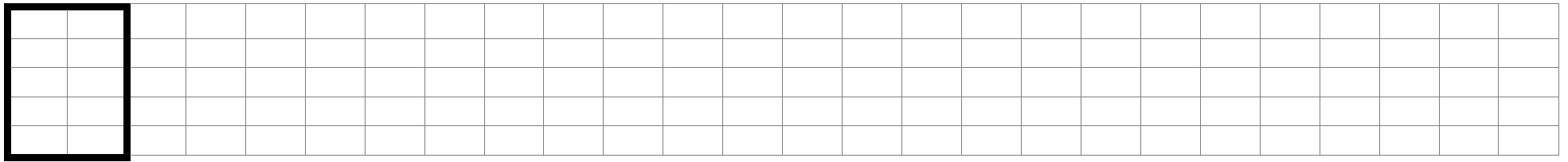
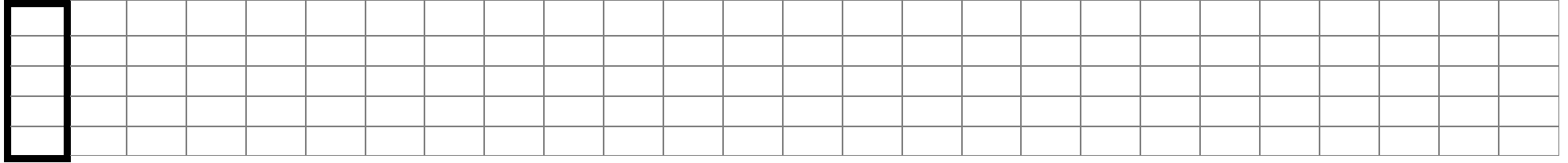

## Grafomotricidad formas y cenefas

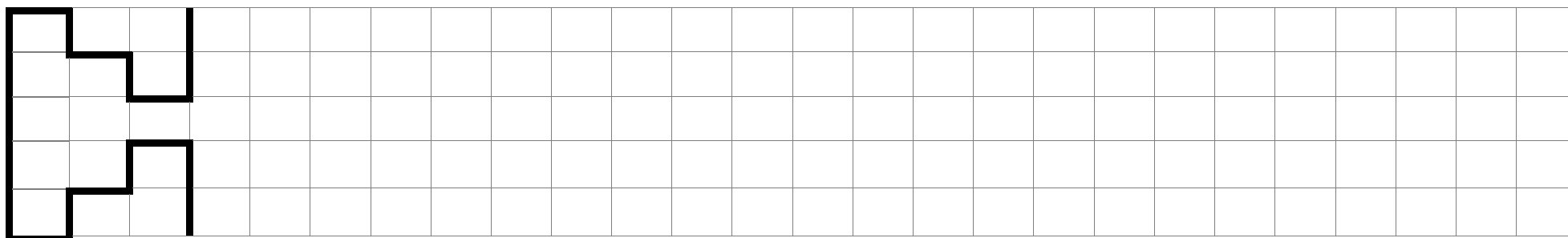
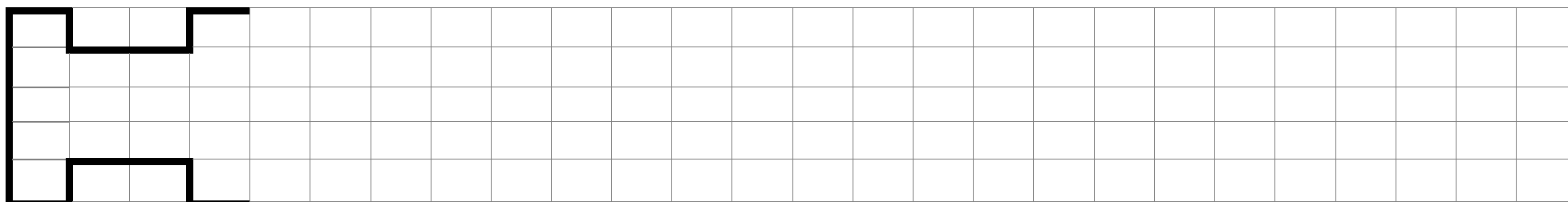
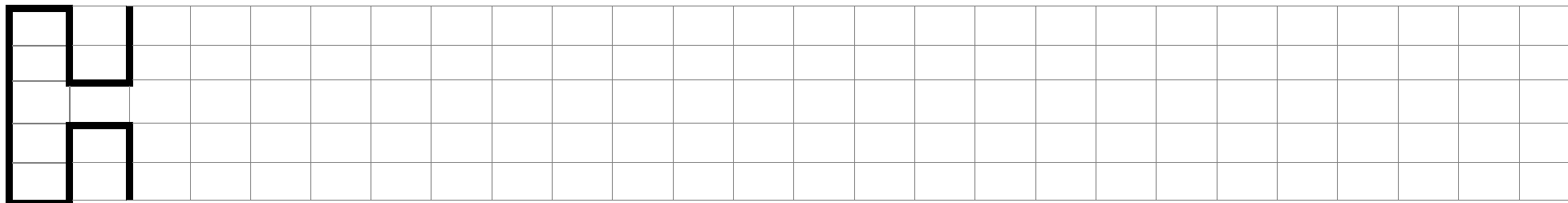

## Actividades para mejorar la psicomotricidad

Sigue los huevos para unir la gallina y el pollito

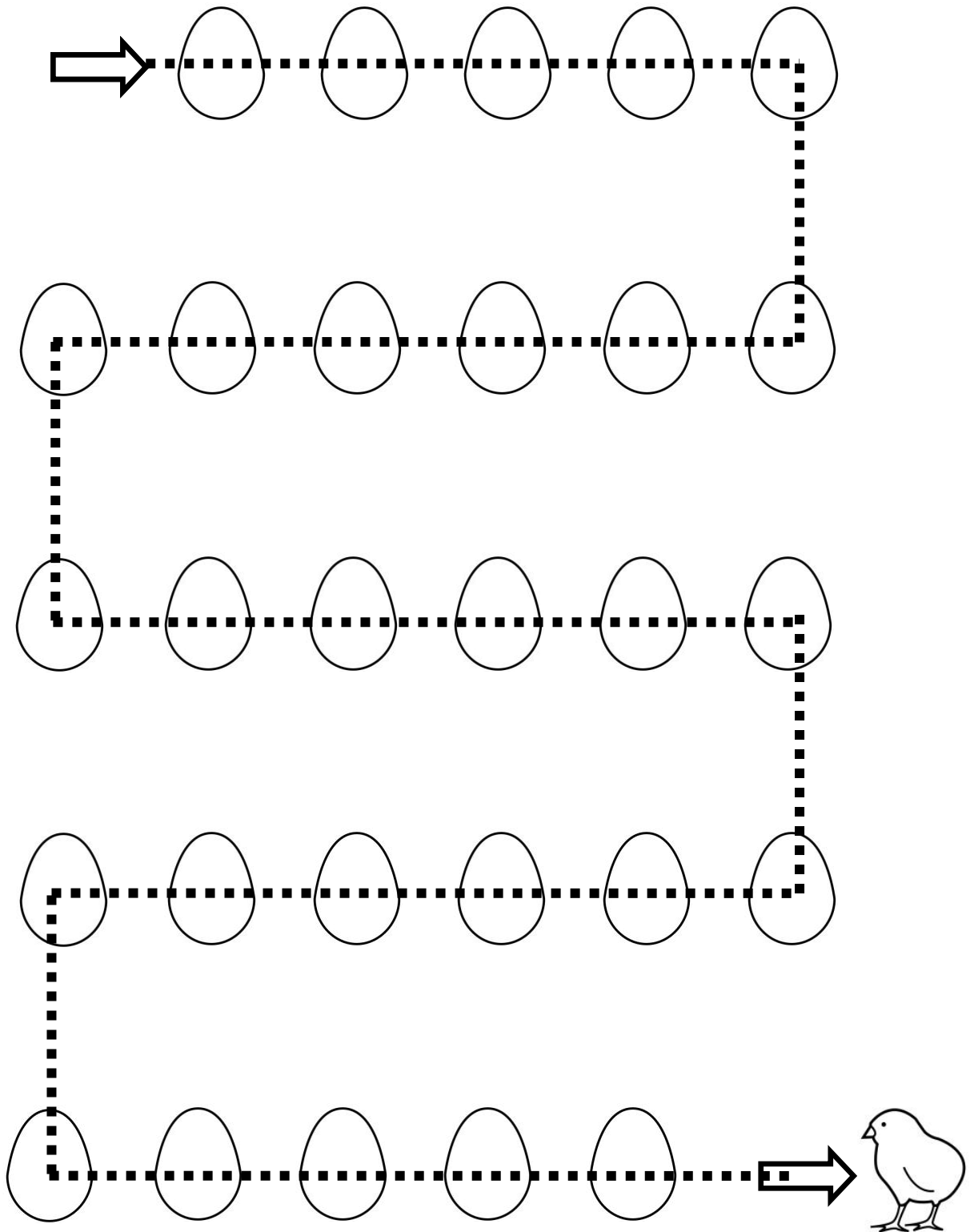
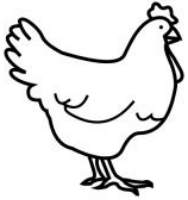

# Actividades para mejorar la psicomotricidad

Sigue los huevos para unir la gallina y el pollito

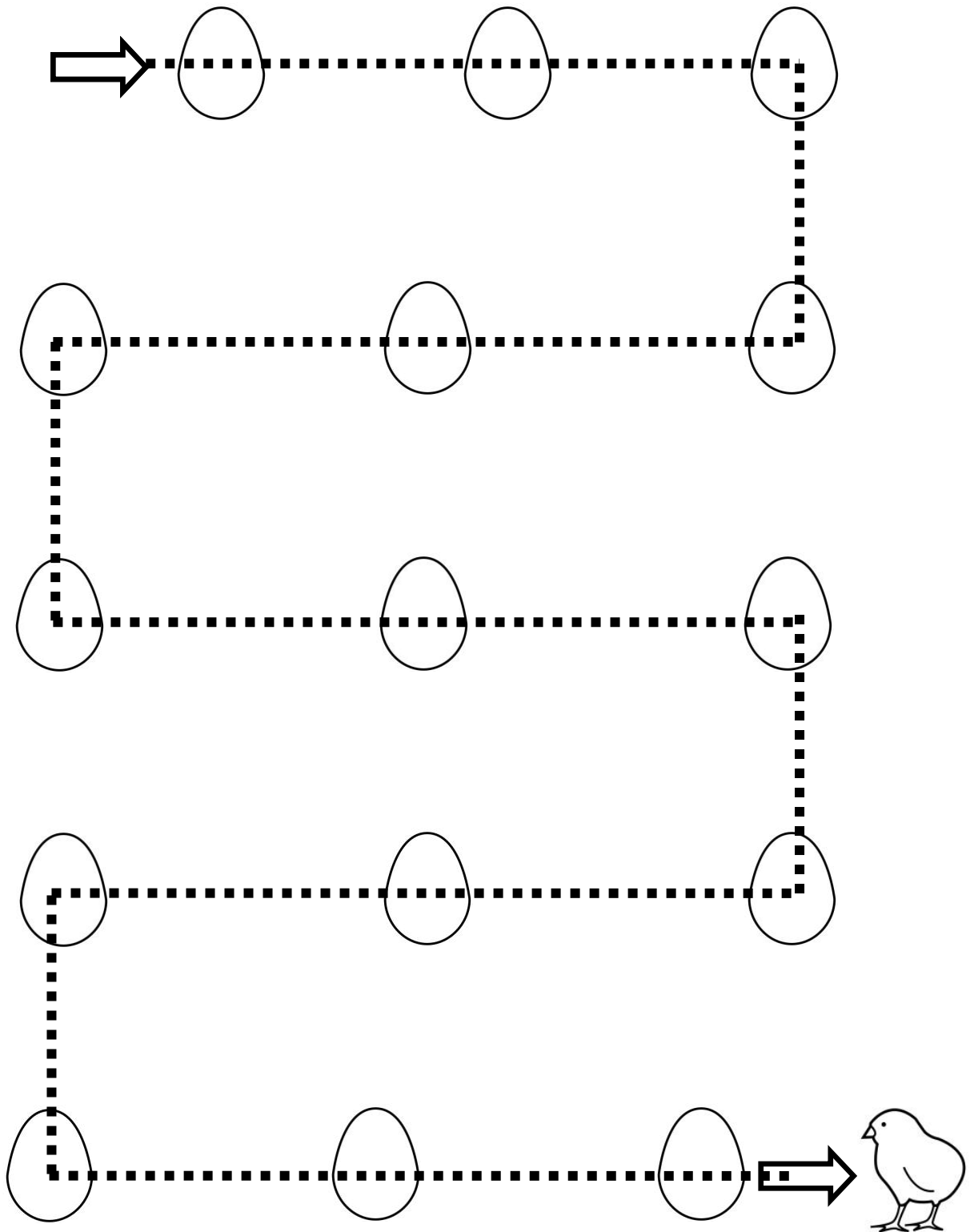
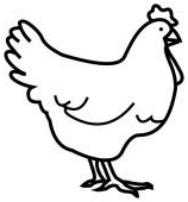

# Actividades para mejorar la psicomotricidad

Sigue los huevos para unir la gallina y el pollito

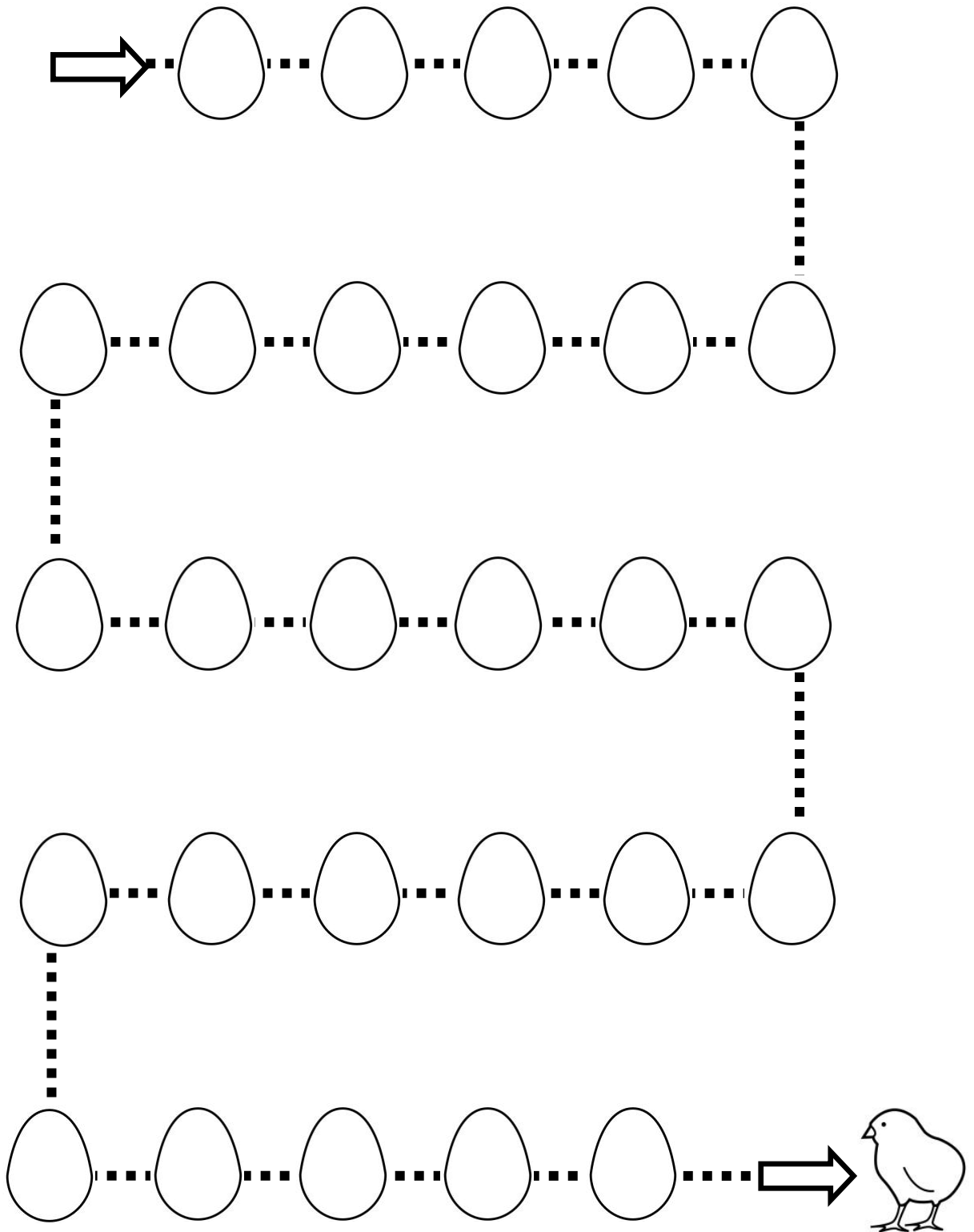
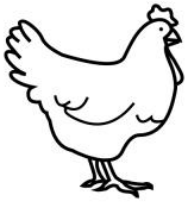

# Actividades para mejorar la psicomotricidad

Sigue los huevos para unir la gallina y el pollito

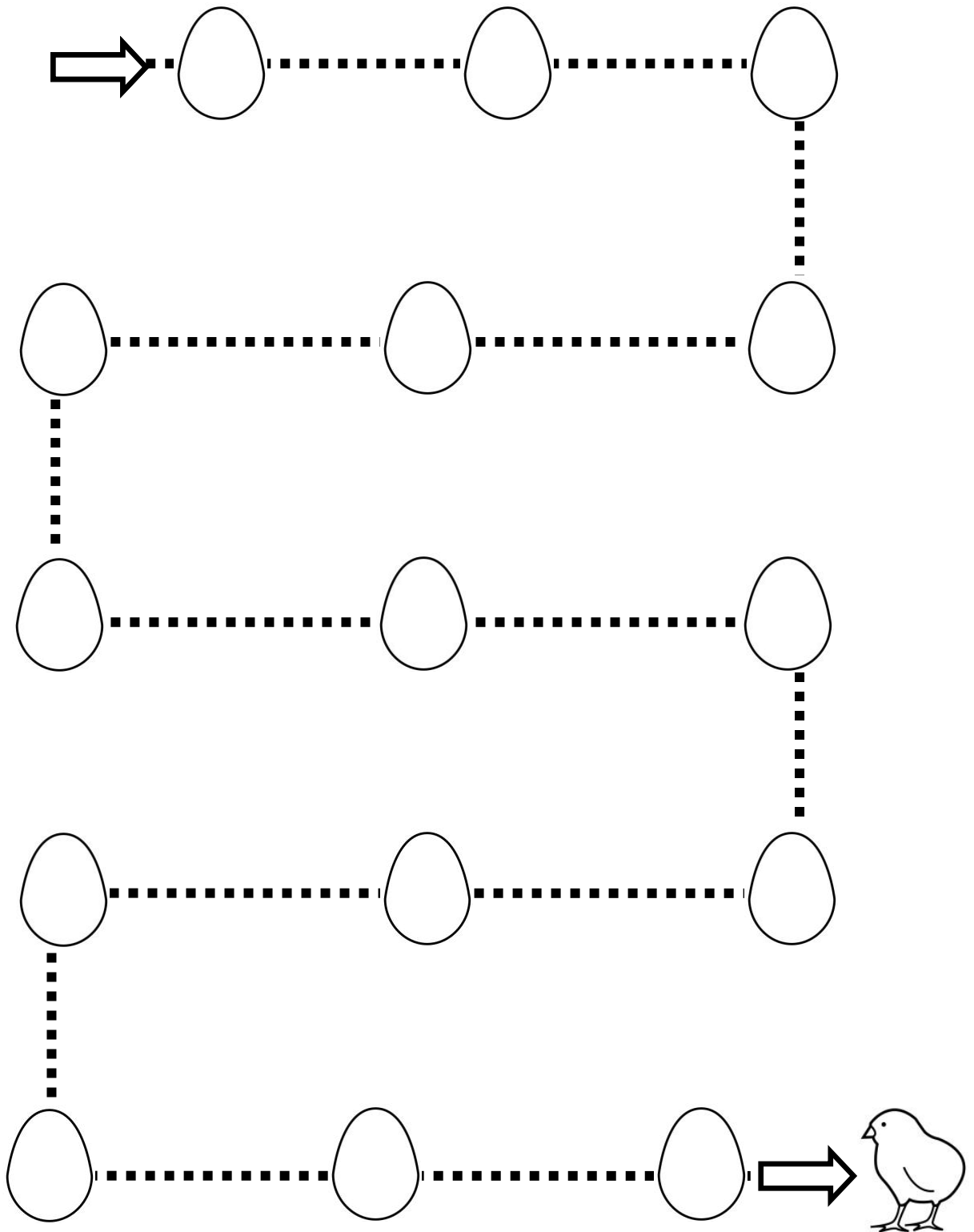
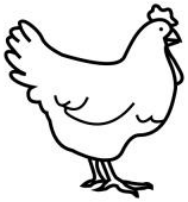

# Actividades para mejorar la psicomotricidad

Sigue los huevos para unir la gallina y el pollito

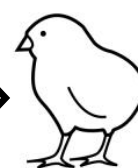
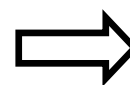
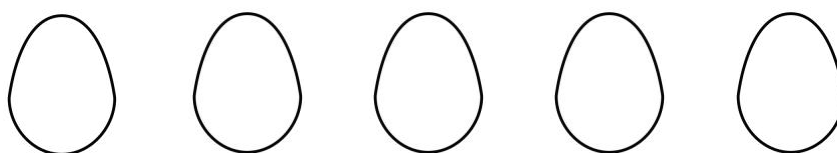
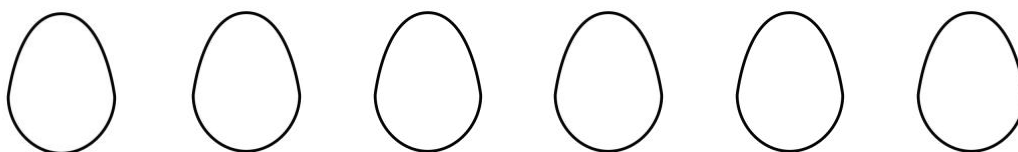
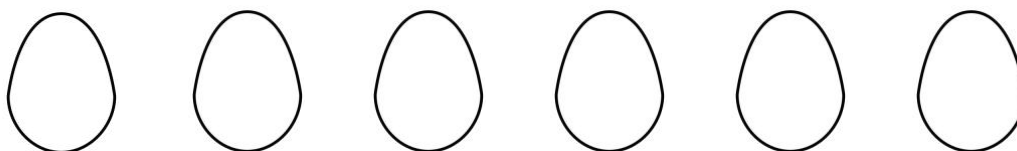
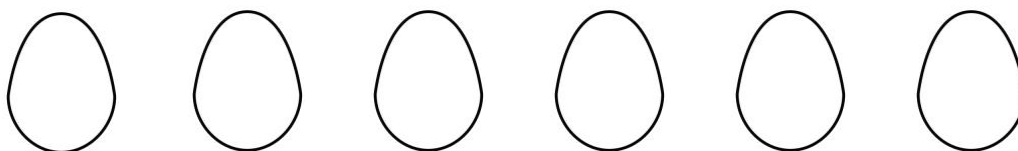
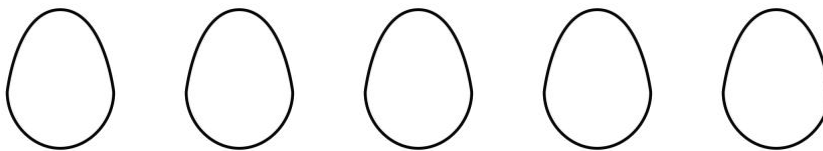
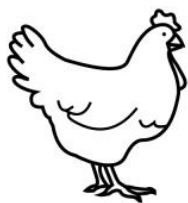

# Actividades para mejorar la psicomotricidad

Sigue los huevos para unir la gallina y el pollito

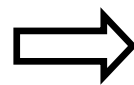
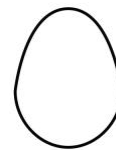
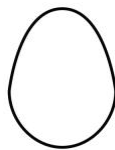
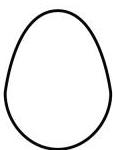
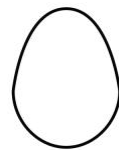
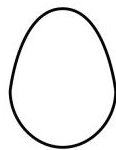
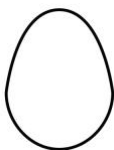
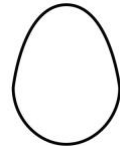
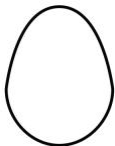
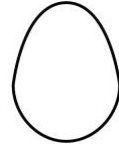
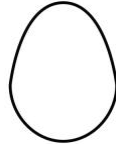
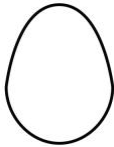
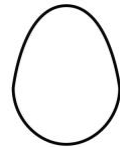
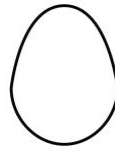
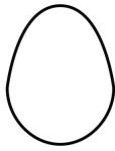
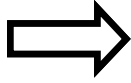
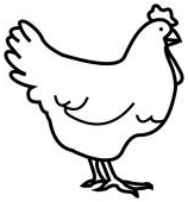



# Actividades para mejorar la psicomotricidad

Sigue los corazones para unir a la mama y a su bebe

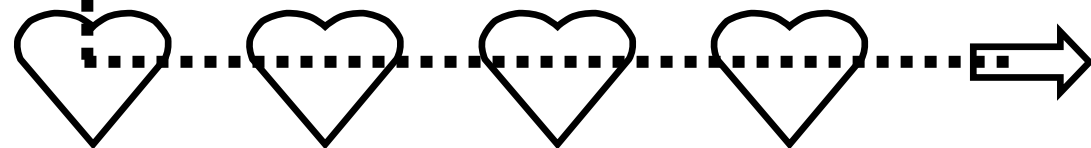
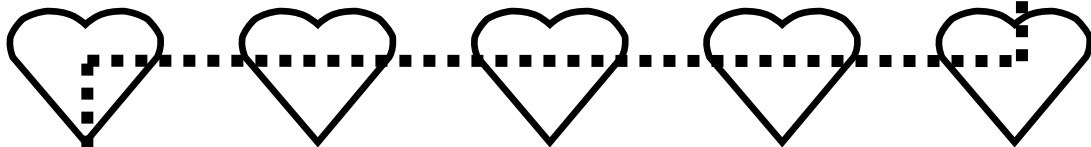
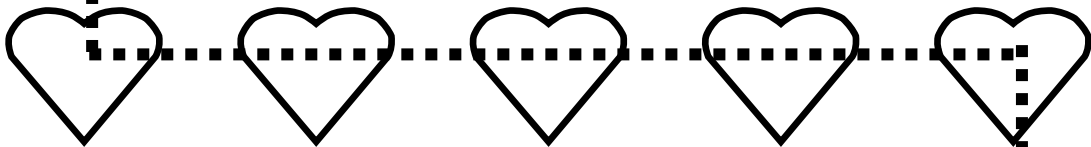
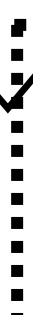
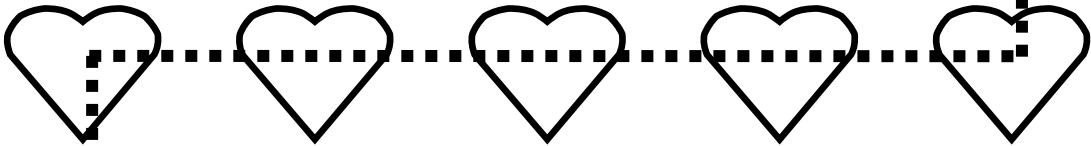
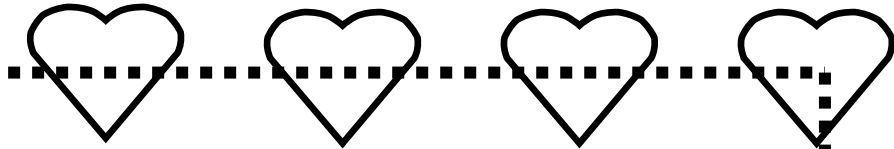

# Actividades para mejorar la psicomotricidad

Sigue los corazones para unir a la mama y a su bebe

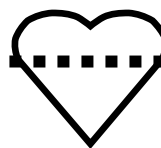
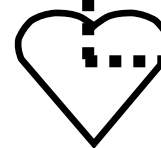
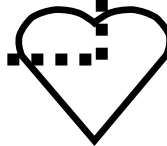
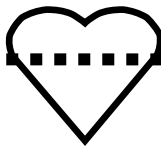
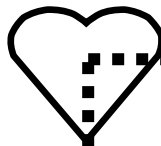
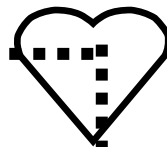
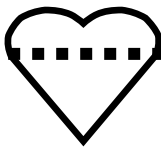
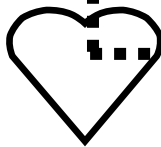
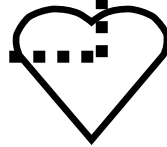
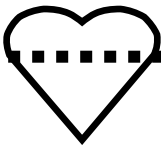
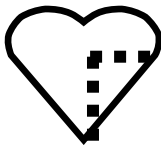
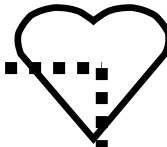
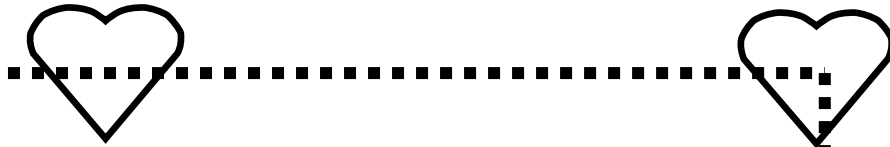
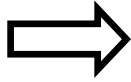

# Actividades para mejorar la psicomotricidad

Sigue los corazones para unir a la mama y a su bebe

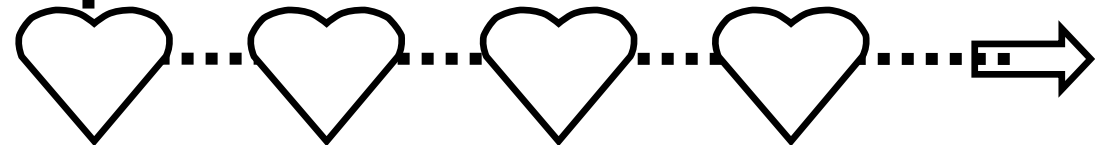
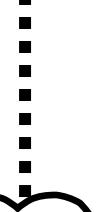
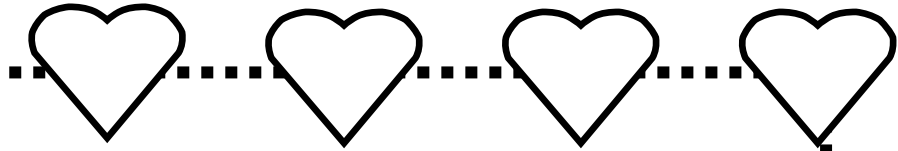

# Actividades para mejorar la psicomotricidad

Sigue los corazones para unir a la mama y a su bebe

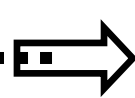
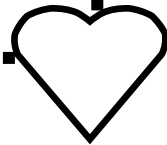
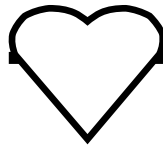

# Actividades para mejorar la psicomotricidad

Sigue los corazones para unir a la mama y a su bebe

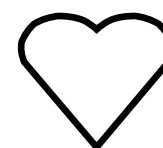
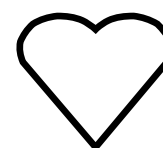
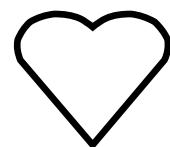
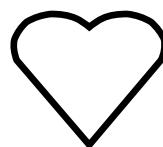
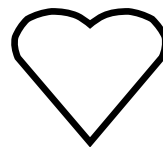
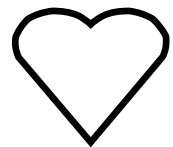

# Actividades para mejorar la psicomotricidad

Sigue los corazones para unir a la mama y a su bebe

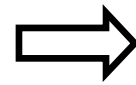
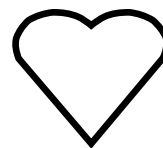
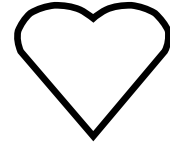

# Actividades para mejorar la psicomotricidad

Sigue las caras para unir al niño y a la niña

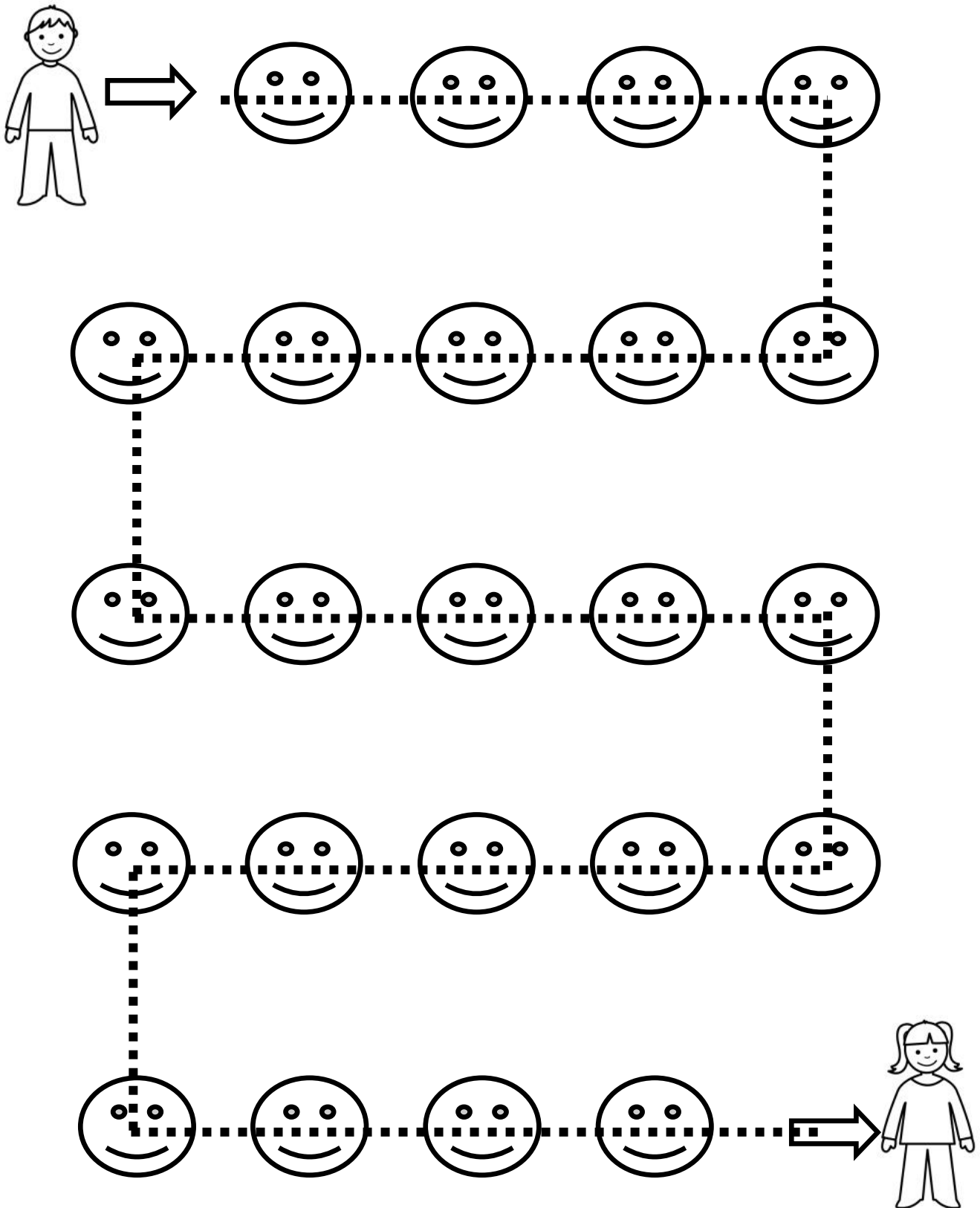

# Actividades para mejorar la psicomotricidad

Sigue las caras para unir al niño y a la niña

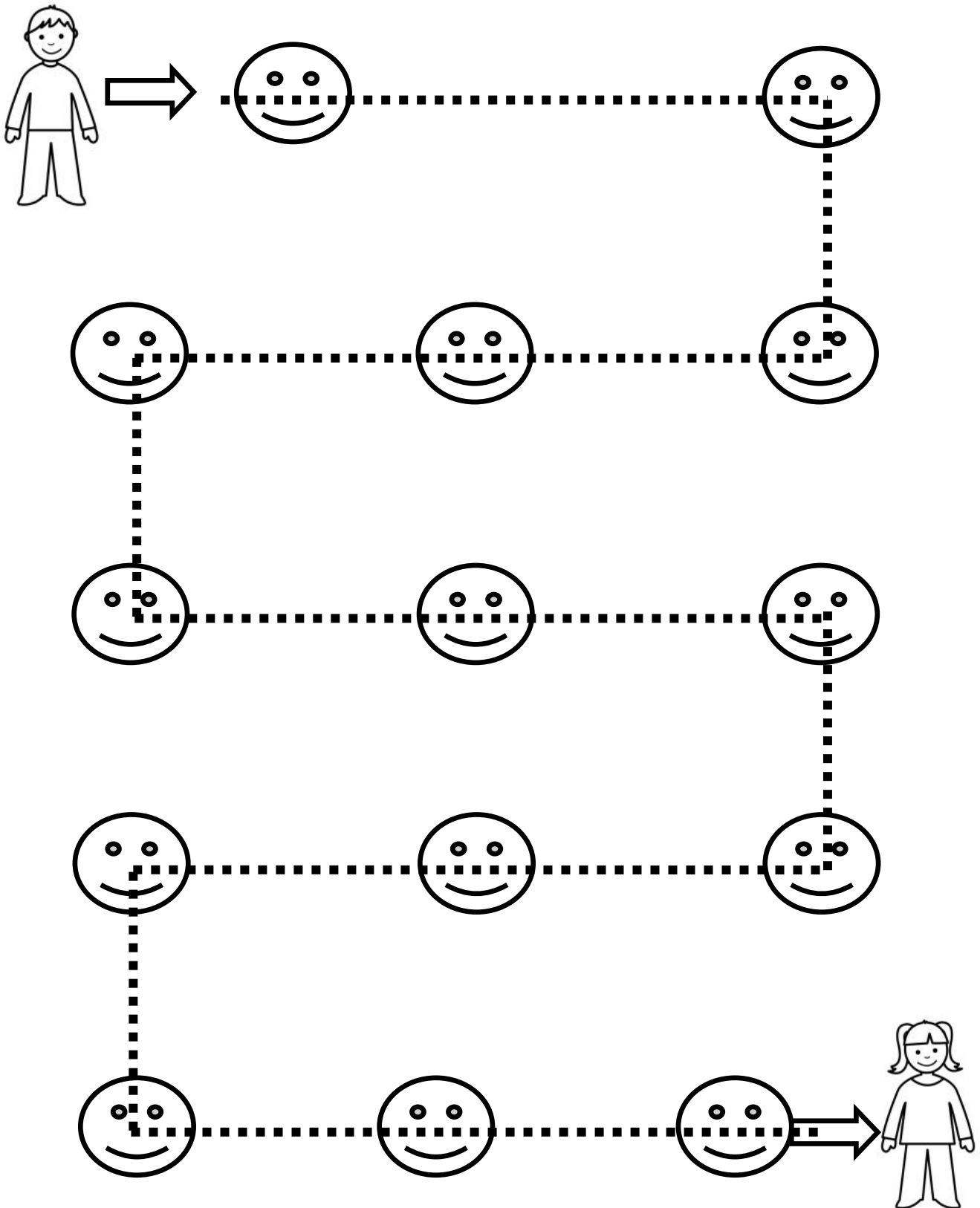



# Actividades para mejorar la psicomotricidad

Sigue las caras para unir al niño y a la niña

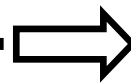
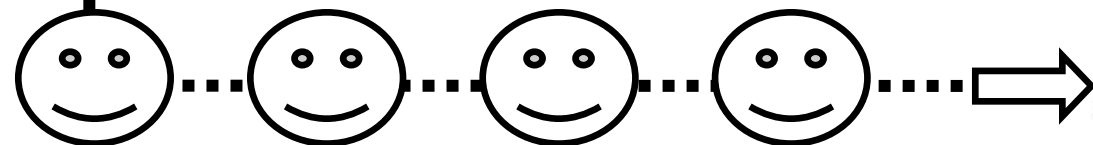
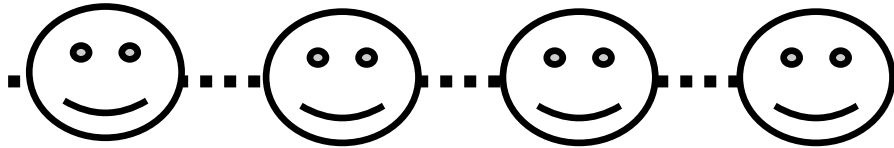
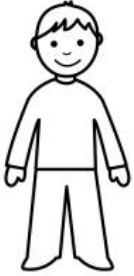

# Actividades para mejorar la psicomotricidad

Sigue las caras para unir al niño y a la niña

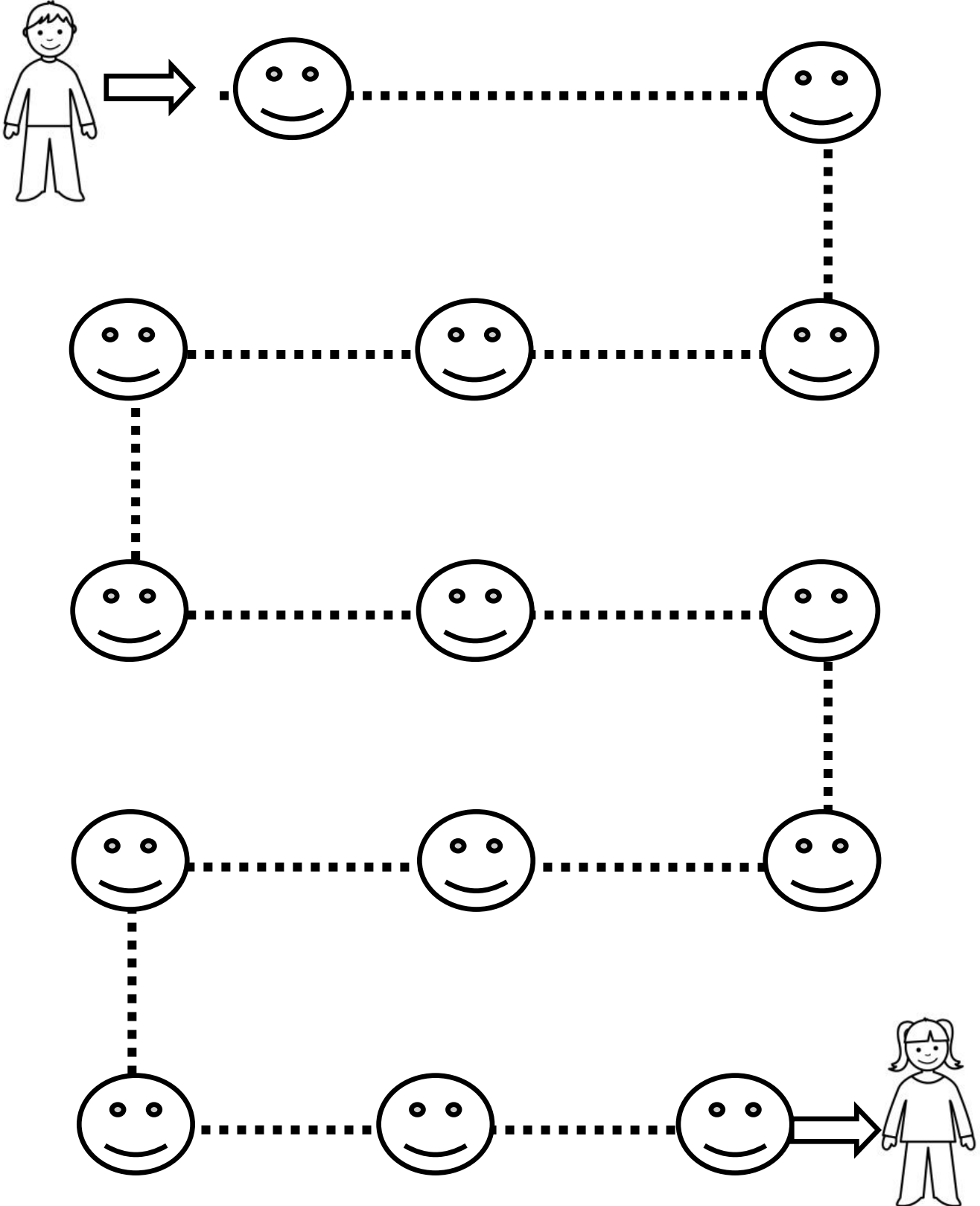

# Actividades para mejorar la psicomotricidad

Sigue las caras para unir al niño y a la niña

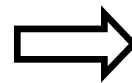
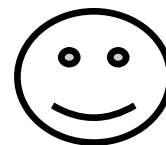
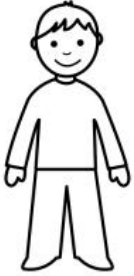

# Actividades para mejorar la psicomotricidad

Sigue las caras para unir al niño y a la niña

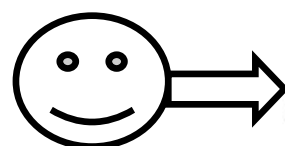
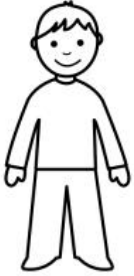

# Actividades para mejorar la psicomotricidad

Sigue los círculos para unir al niño con su balón

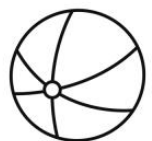
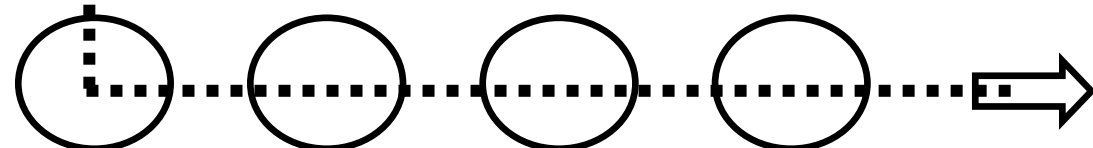
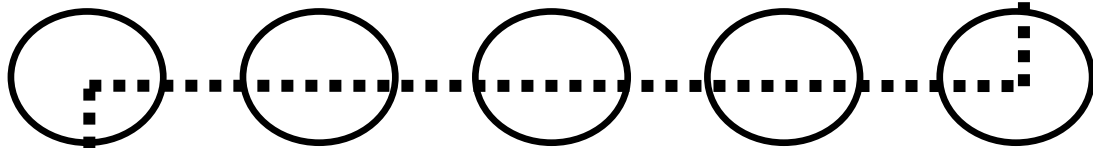
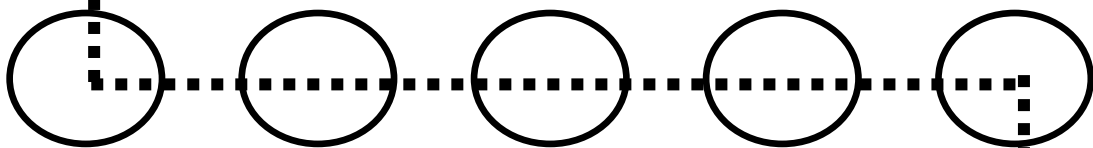
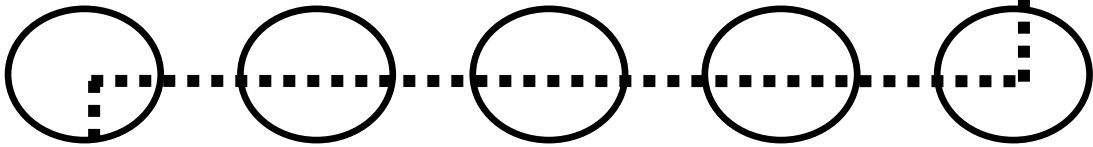
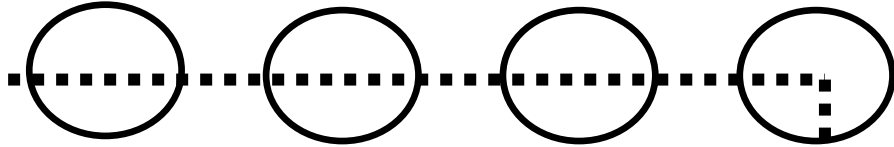
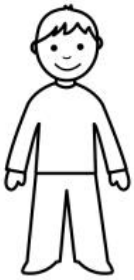

# Actividades para mejorar la psicomotricidad

Sigue los círculos para unir al niño con su balón

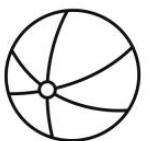
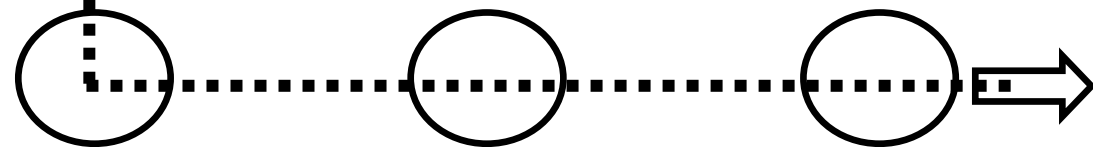
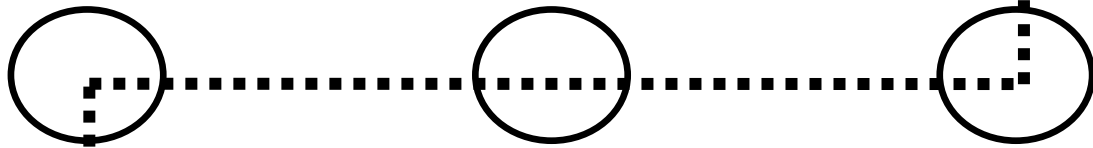
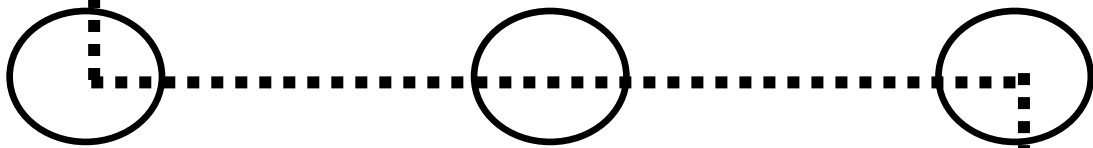
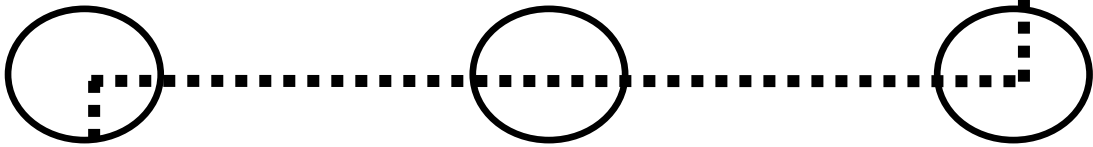
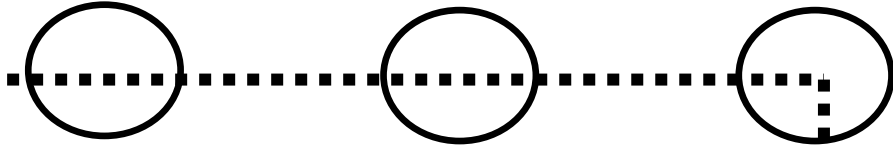
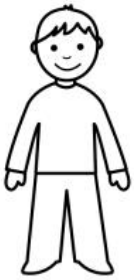

# Actividades para mejorar la psicomotricidad

Sigue los círculos para unir al niño con su balón

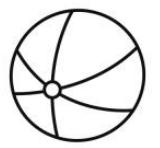
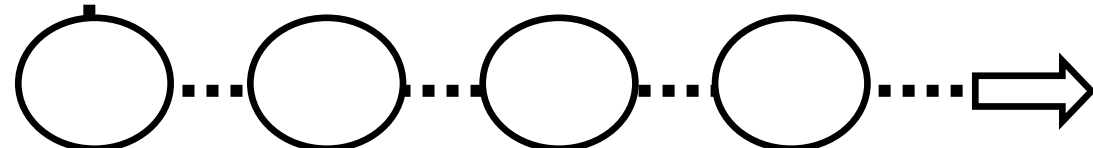
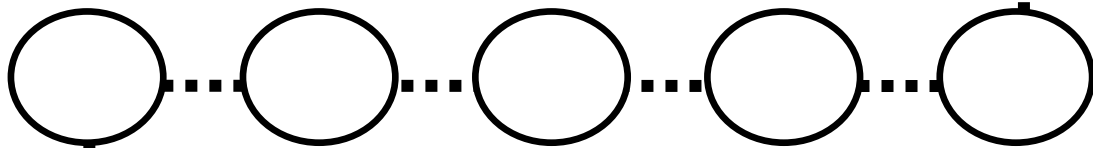
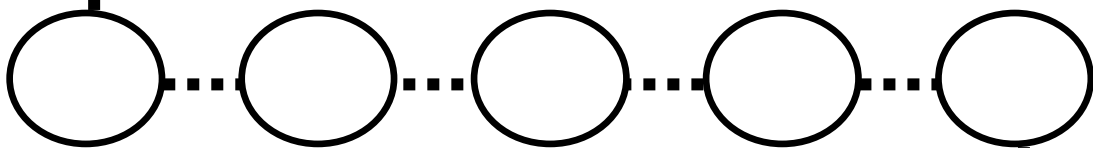
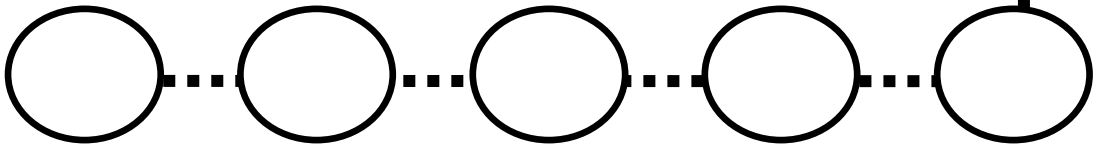
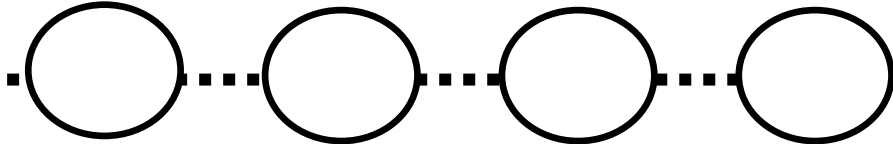
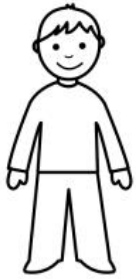

# Actividades para mejorar la psicomotricidad

Sigue los círculos para unir al niño con su balón

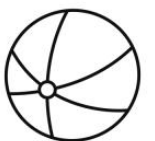
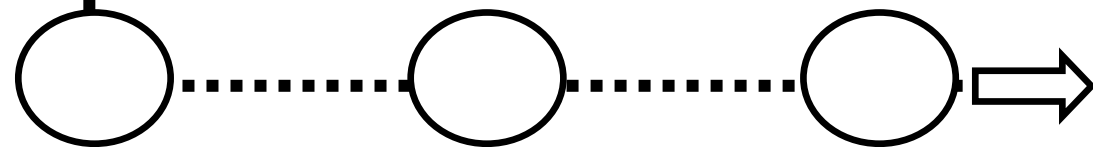
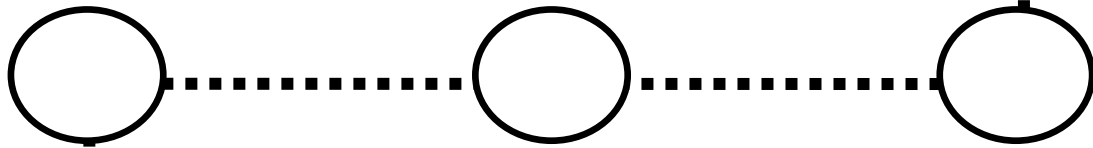
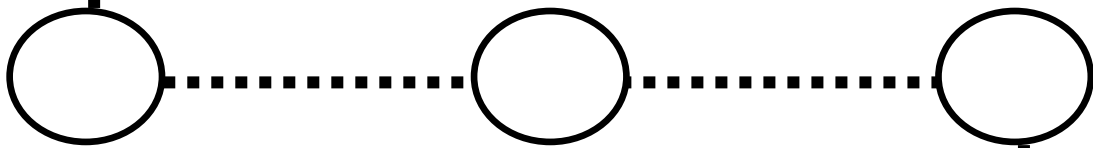
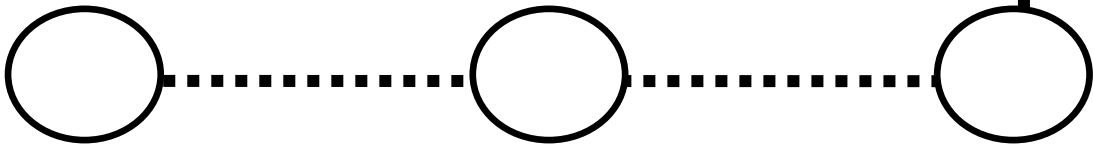
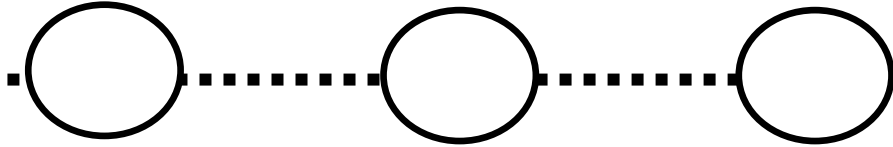
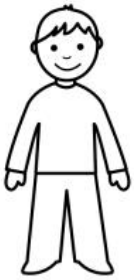



# Actividades para mejorar la psicomotricidad

Sigue los círculos para unir al niño con su balón

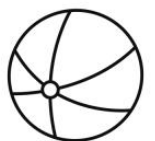
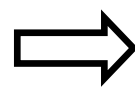
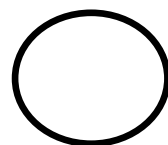
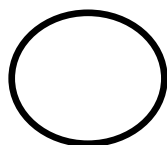
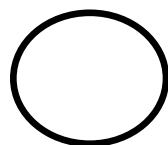
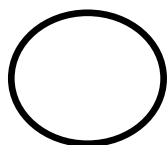
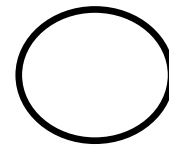
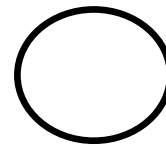
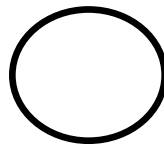
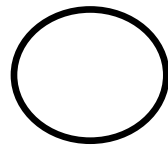
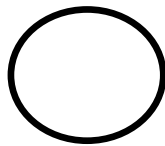
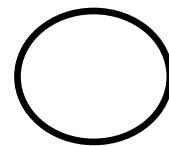
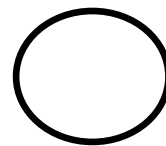
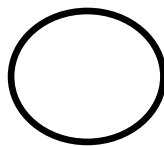
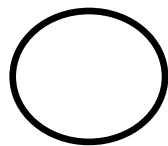
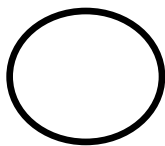
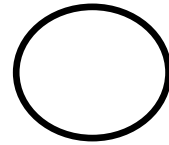
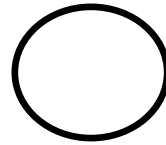
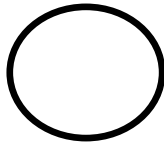
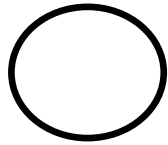
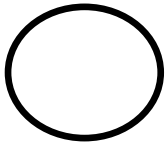
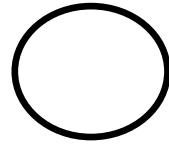
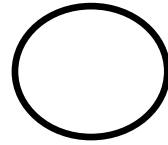
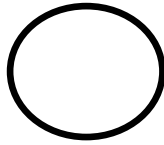
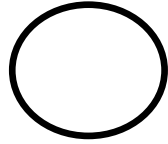
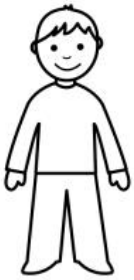

# Actividades para mejorar la psicomotricidad

Sigue los círculos para unir al niño con su balón

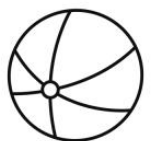
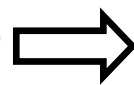
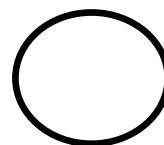
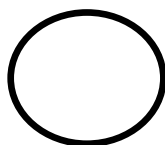
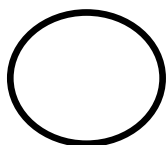
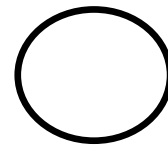
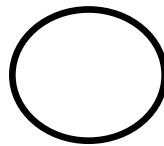
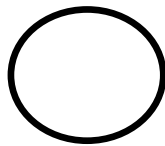
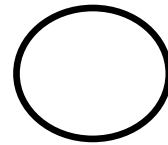
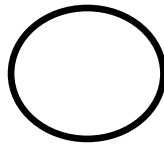
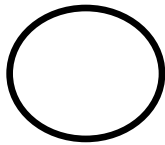
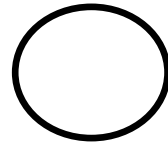
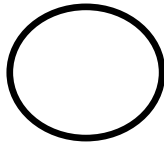
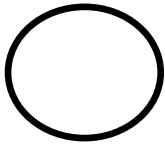
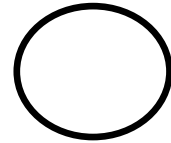
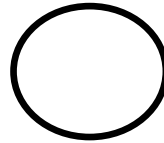
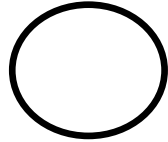
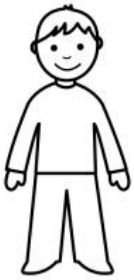

# Actividades para mejorar la psicomotricidad

Sigue los rayos para unir la nube con la tierra

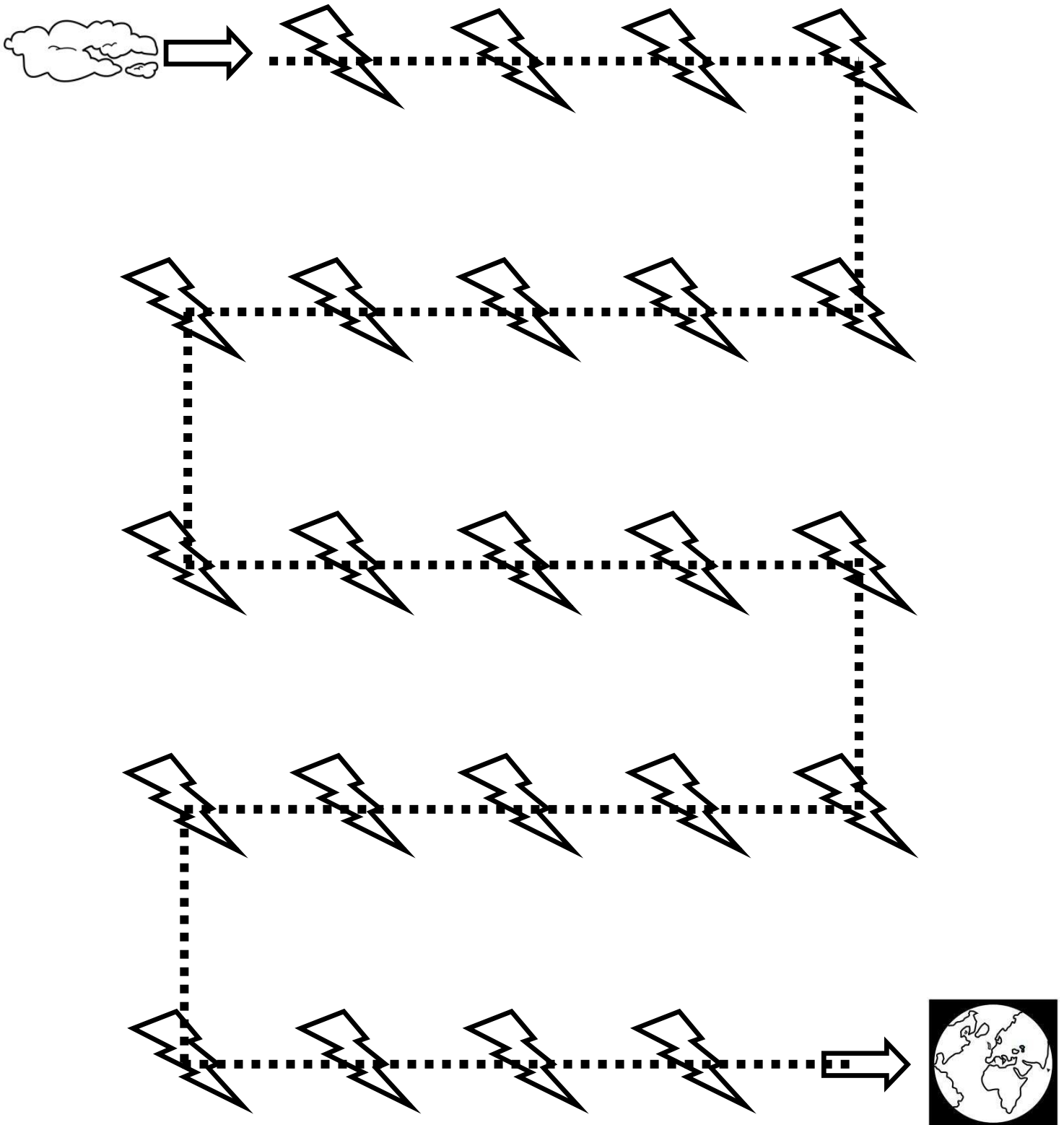

# Actividades para mejorar la psicomotricidad

Sigue las caras para unir al niño y a la niña

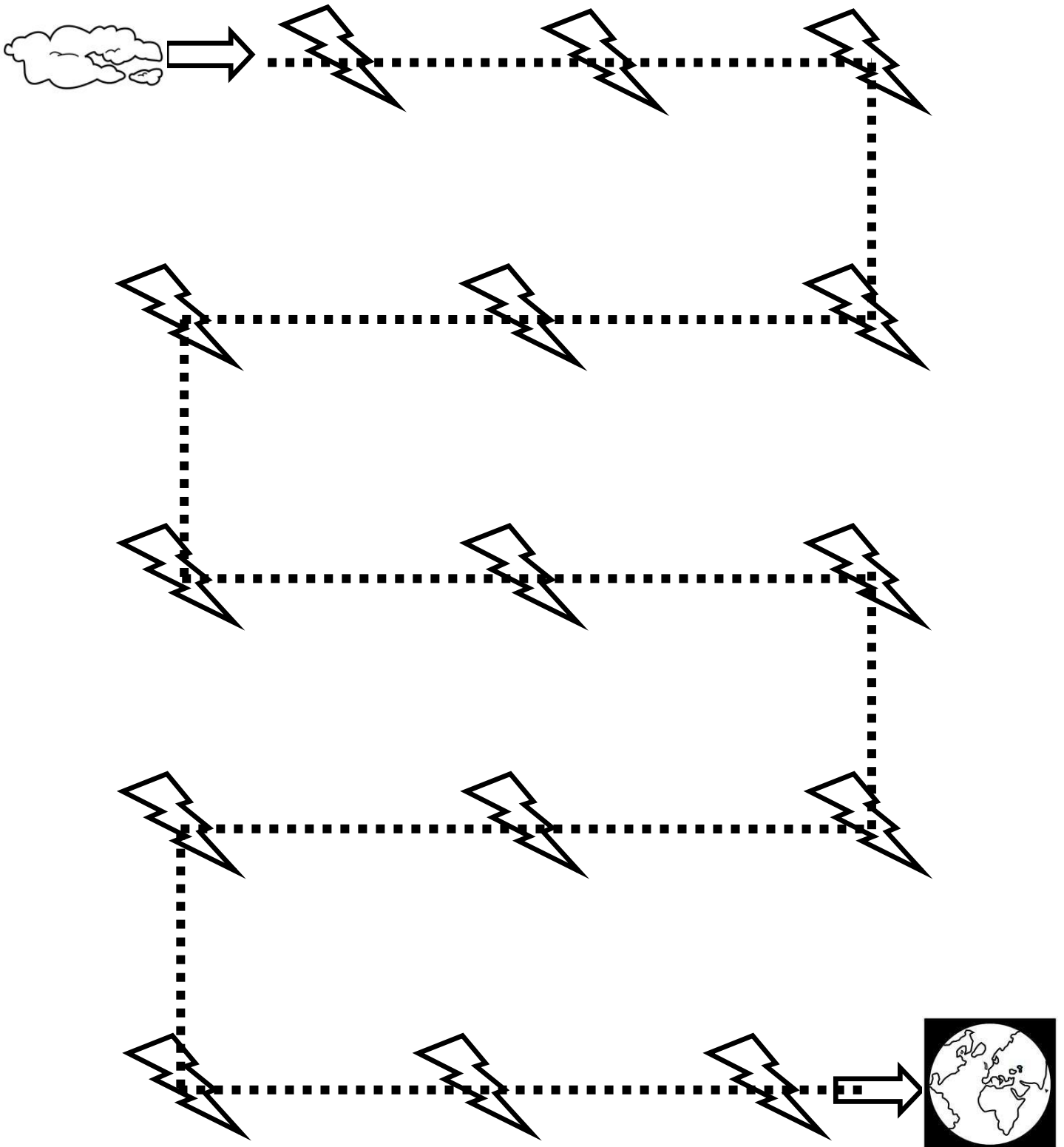

# Actividades para mejorar la psicomotricidad

Sigue las caras para unir al niño y a la niña

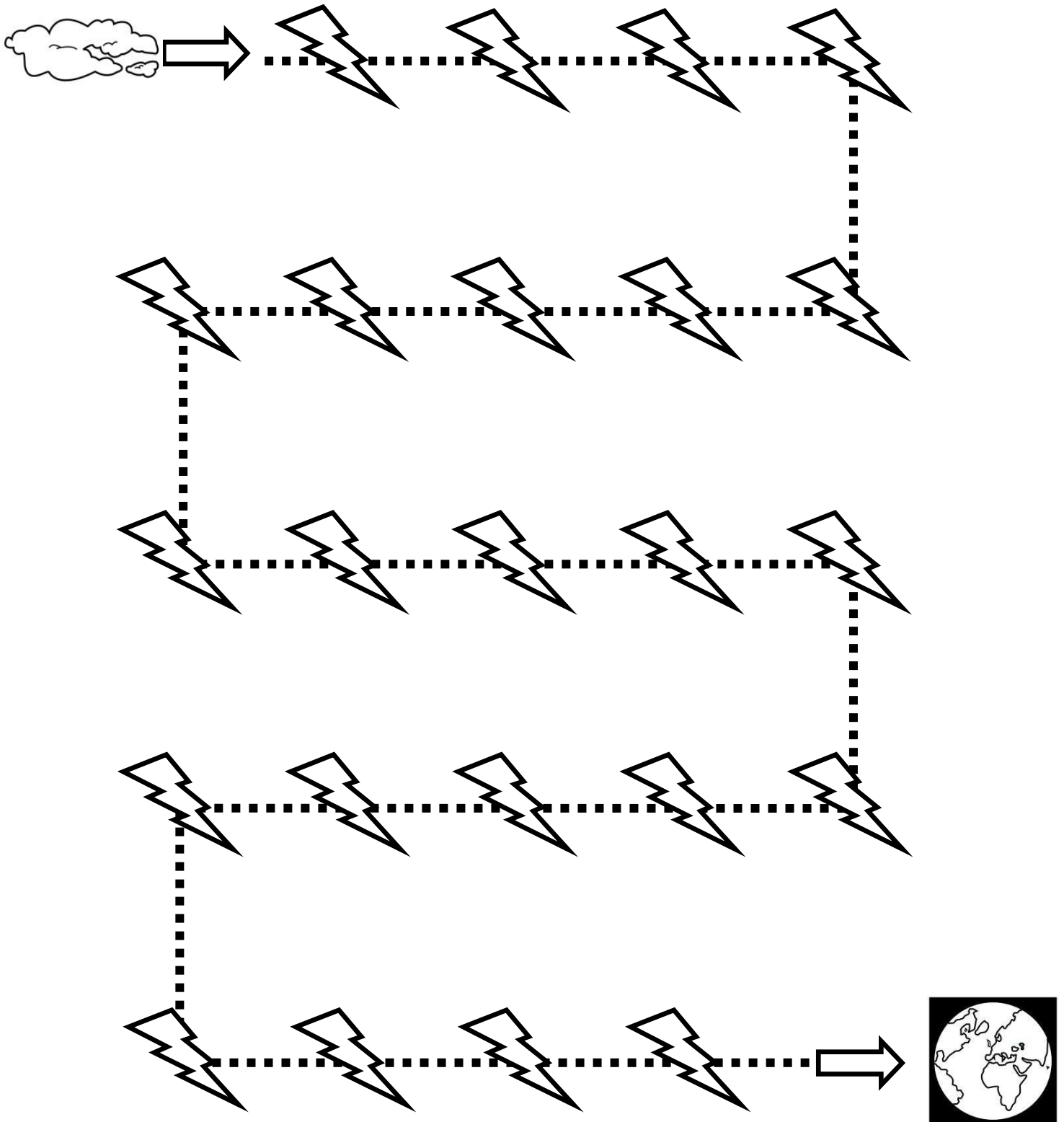

# Actividades para mejorar la psicomotricidad

Sigue las caras para unir al niño y a la niña

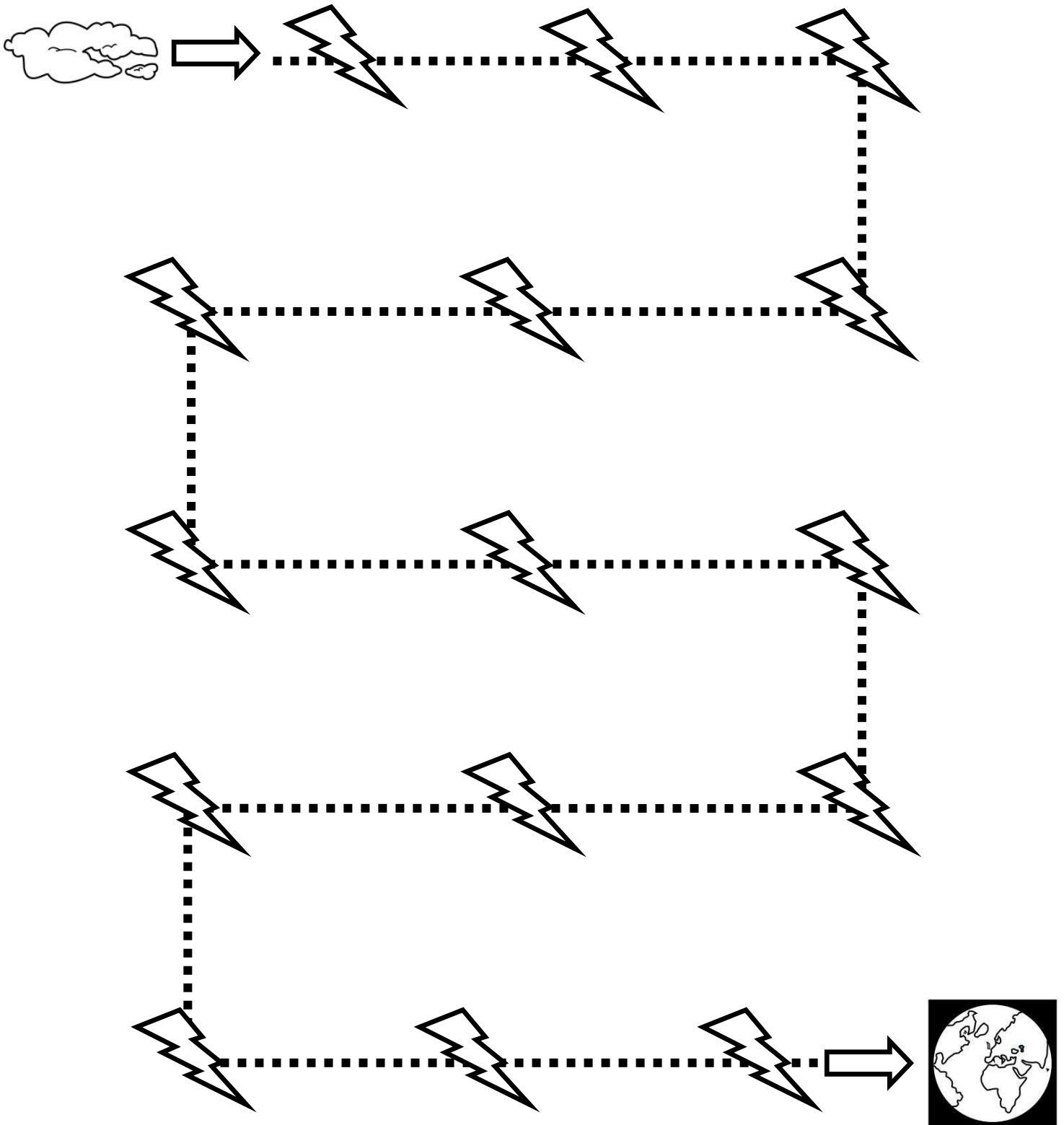

# Actividades para mejorar la psicomotricidad

Sigue las caras para unir al niño y a la niña

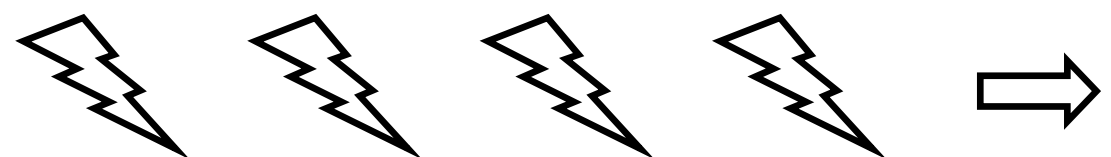
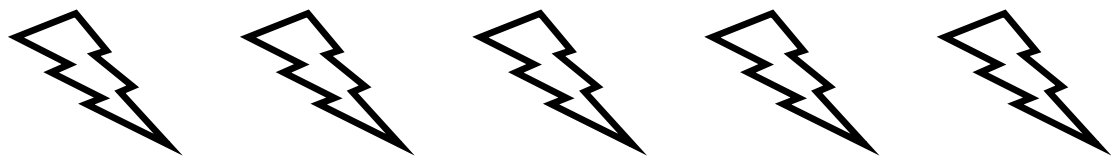
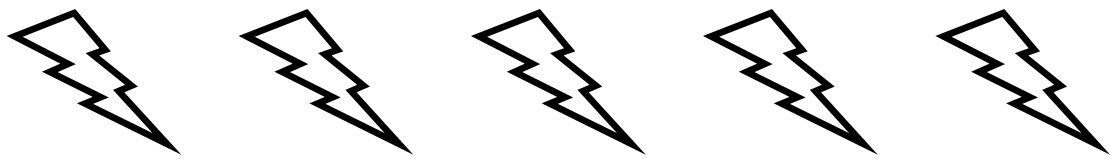
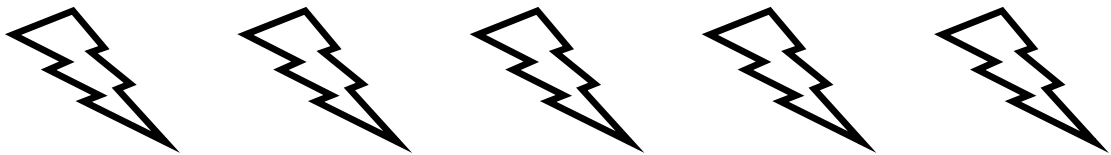
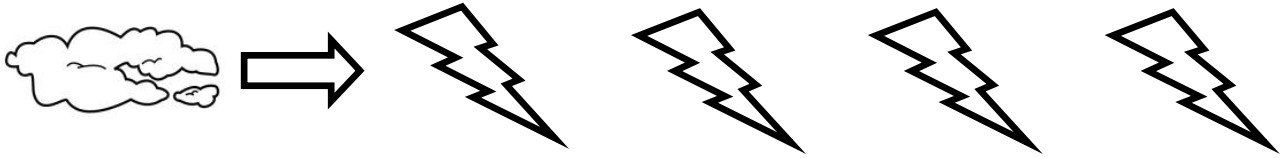

# Actividades para mejorar la psicomotricidad

Sigue las caras para unir al niño y a la niña

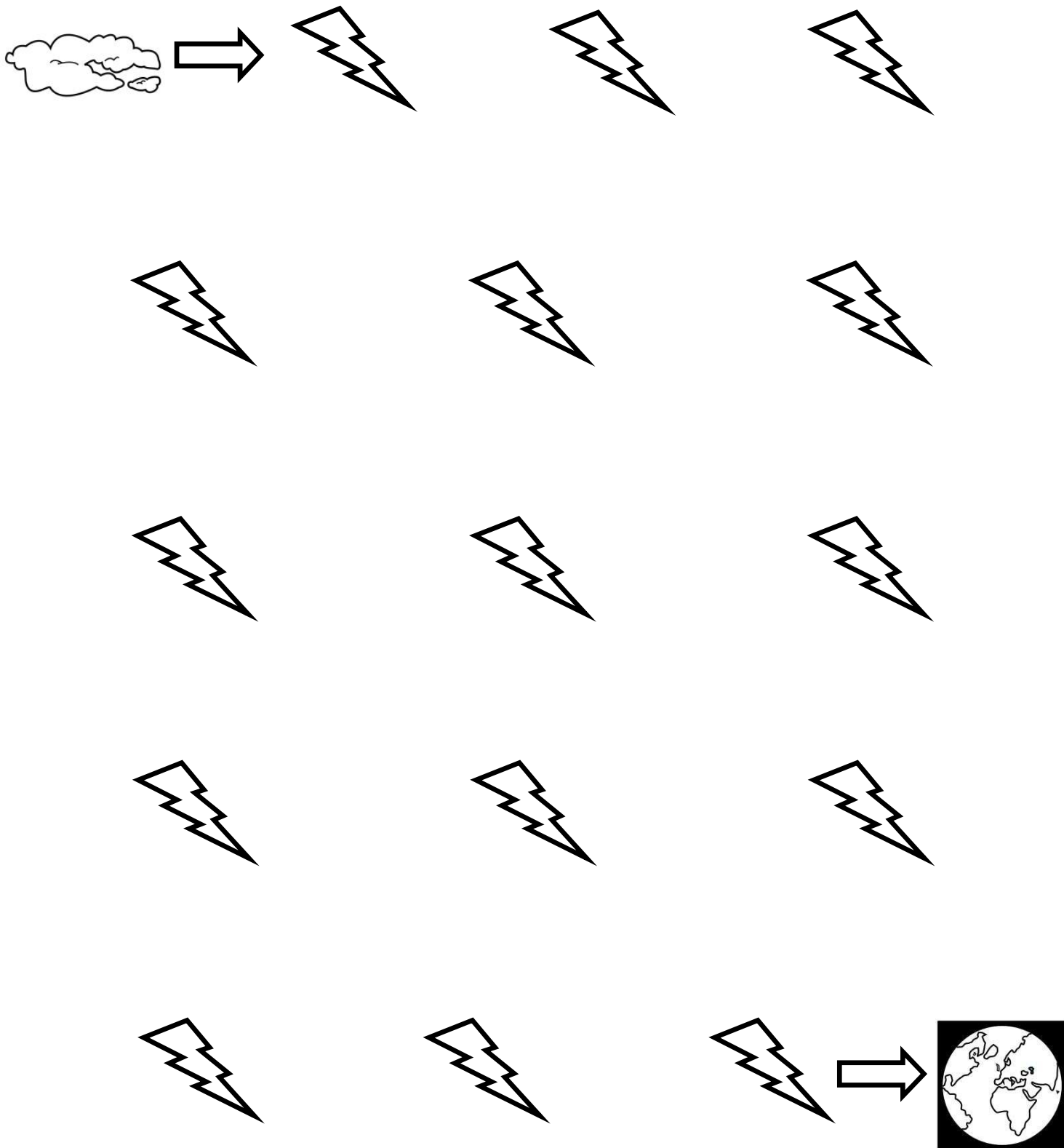



# Actividades para mejorar la psicomotricidad

Sigue las estrellitas para ir desde el sol a la tierra

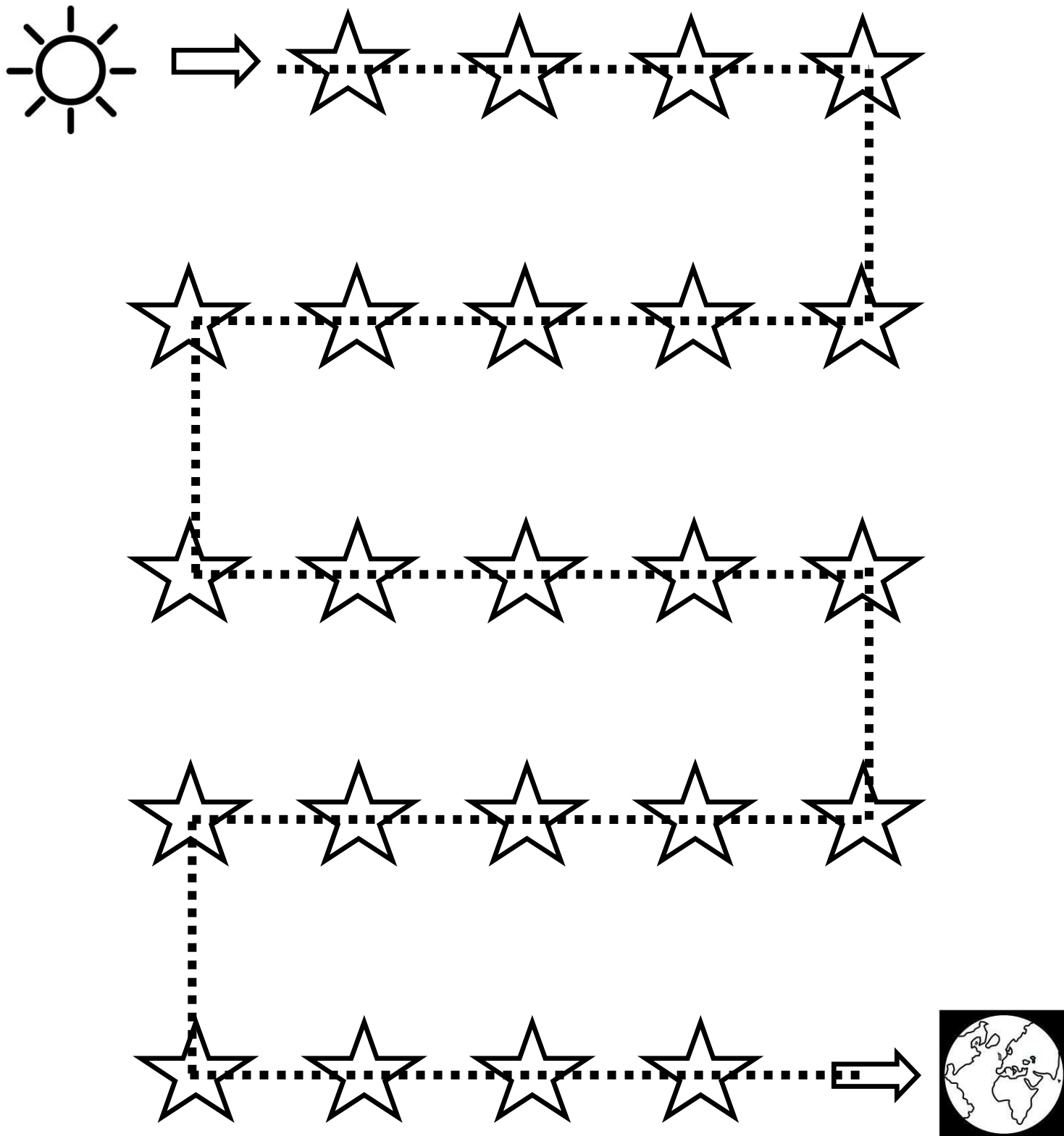

# Actividades para mejorar la psicomotricidad

Sigue las estrellitas para ir desde el sol a la tierra

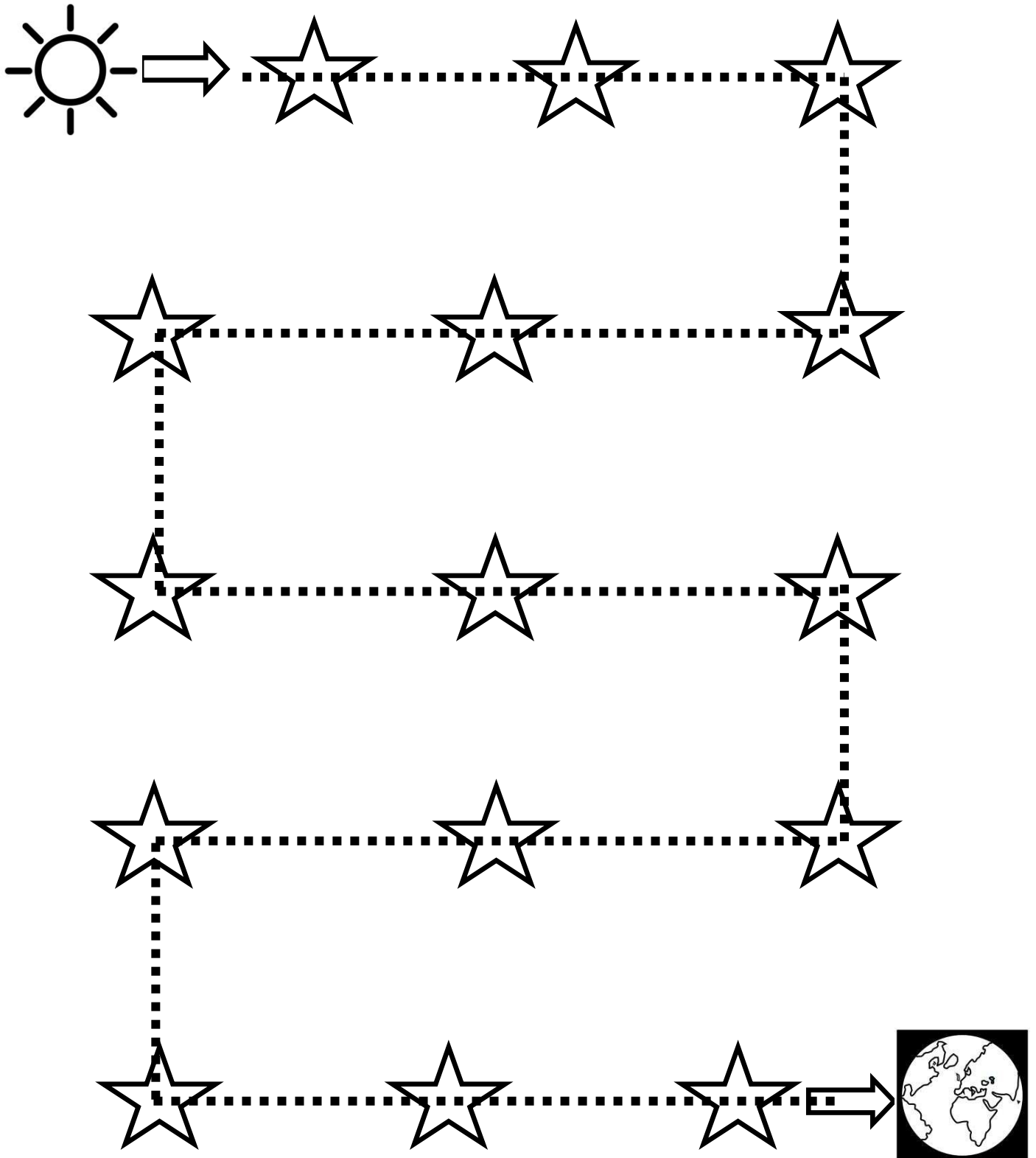

# Actividades para mejorar la psicomotricidad

Sigue las estrellitas para ir desde el sol a la tierra

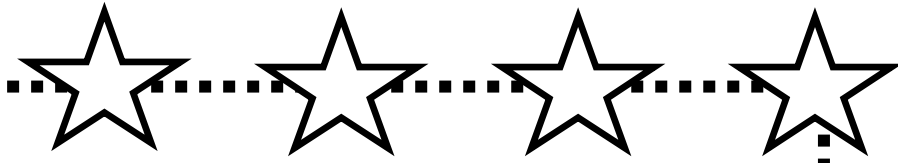
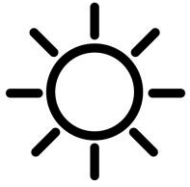

# Actividades para mejorar la psicomotricidad

Sigue las estrellitas para ir desde el sol a la tierra

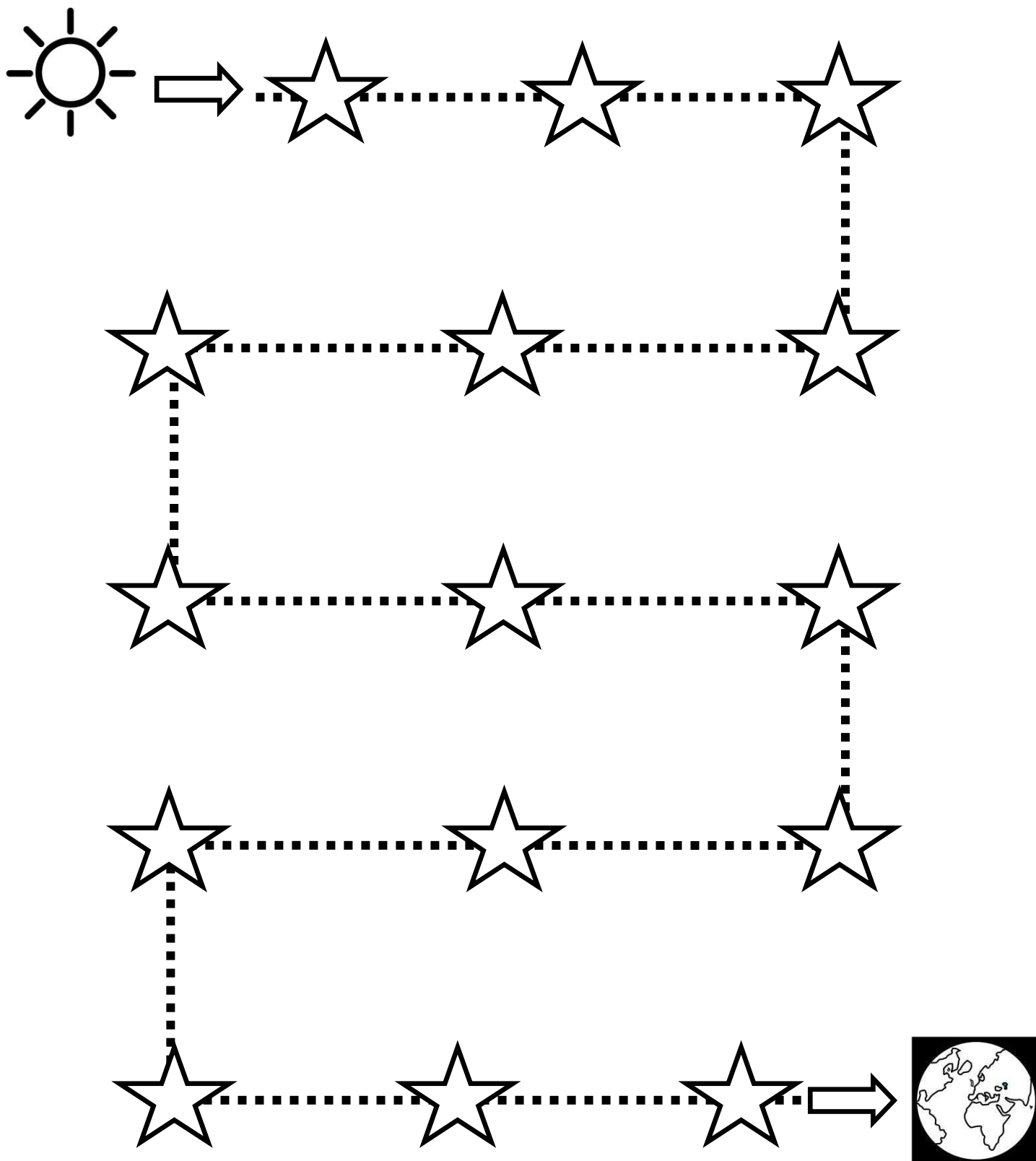

# Actividades para mejorar la psicomotricidad

Sigue las estrellitas para ir desde el sol a la tierra

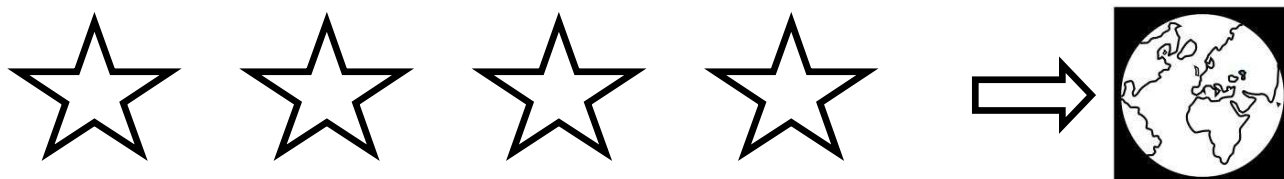
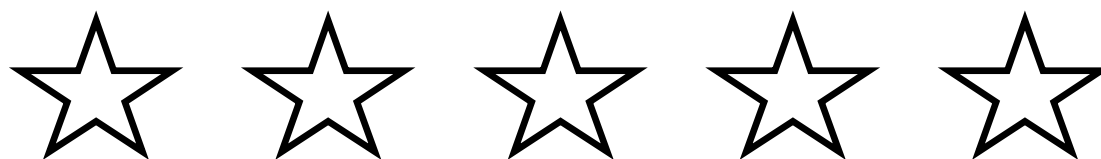
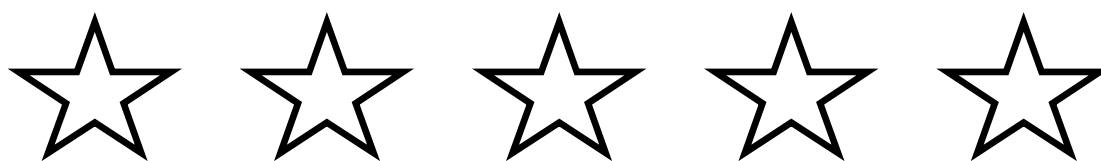
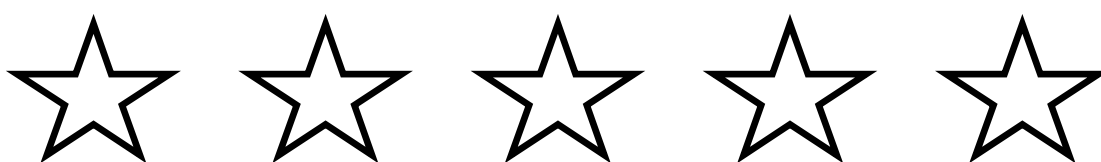
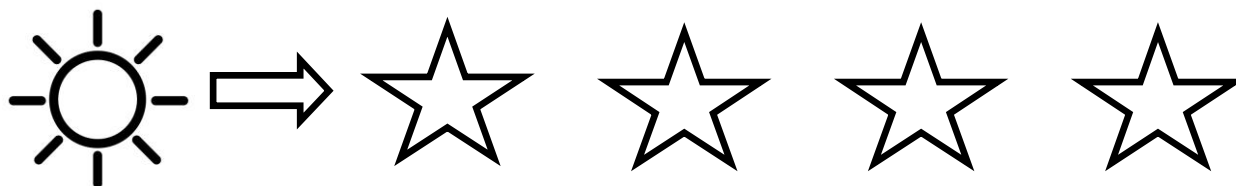

# Actividades para mejorar la psicomotricidad

Sigue las estrellitas para ir desde el sol a la tierra

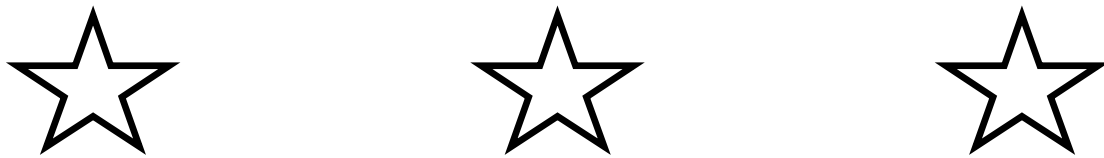

## Actividades para mejorar motricidad fina

Sigue con tu lápiz las estrellitas para ir desde el sol a la tierra

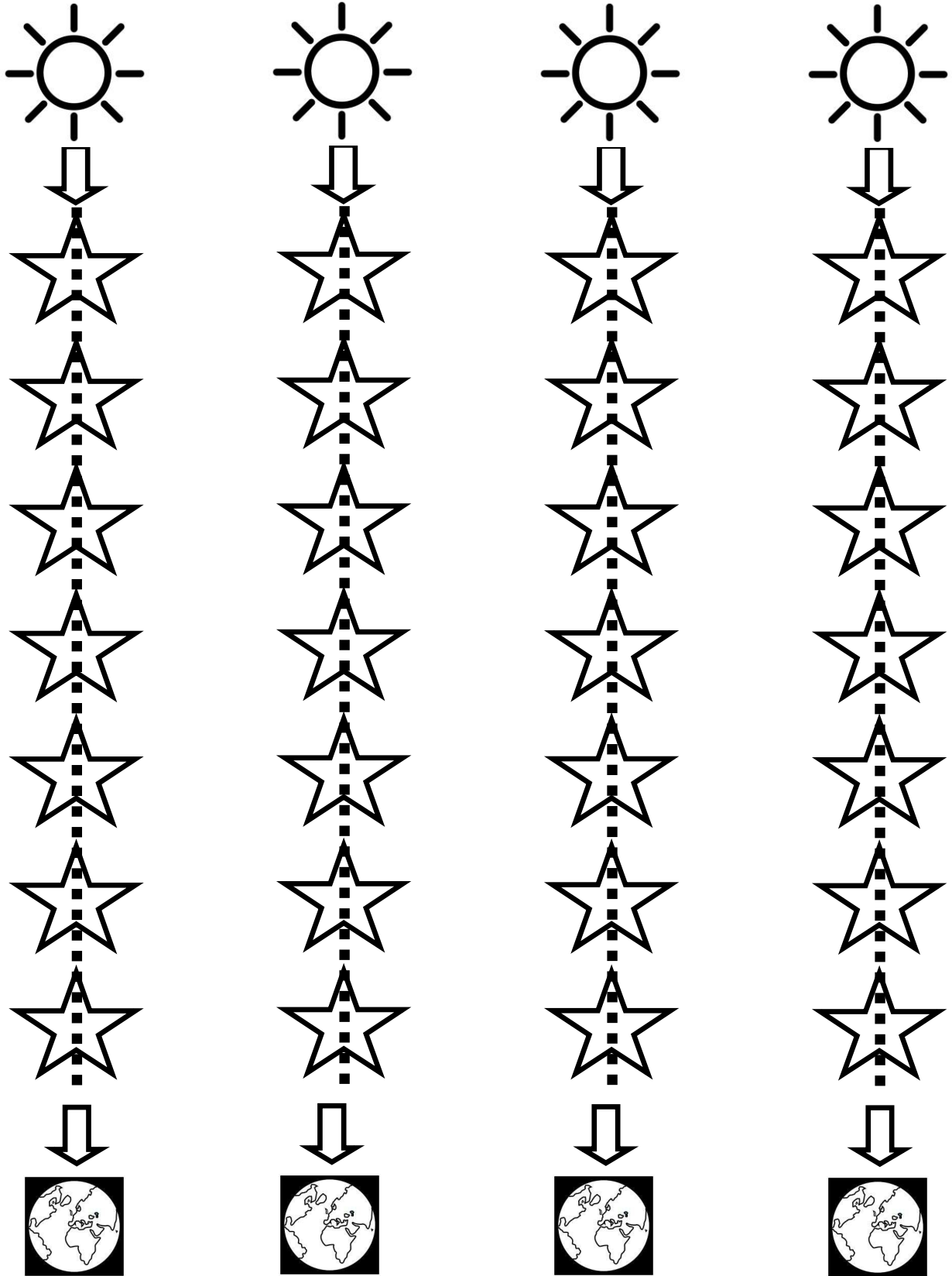

## Actividades para mejorar motricidad fina

Sigue con tu lápiz las estrellitas para ir desde el sol a la tierra

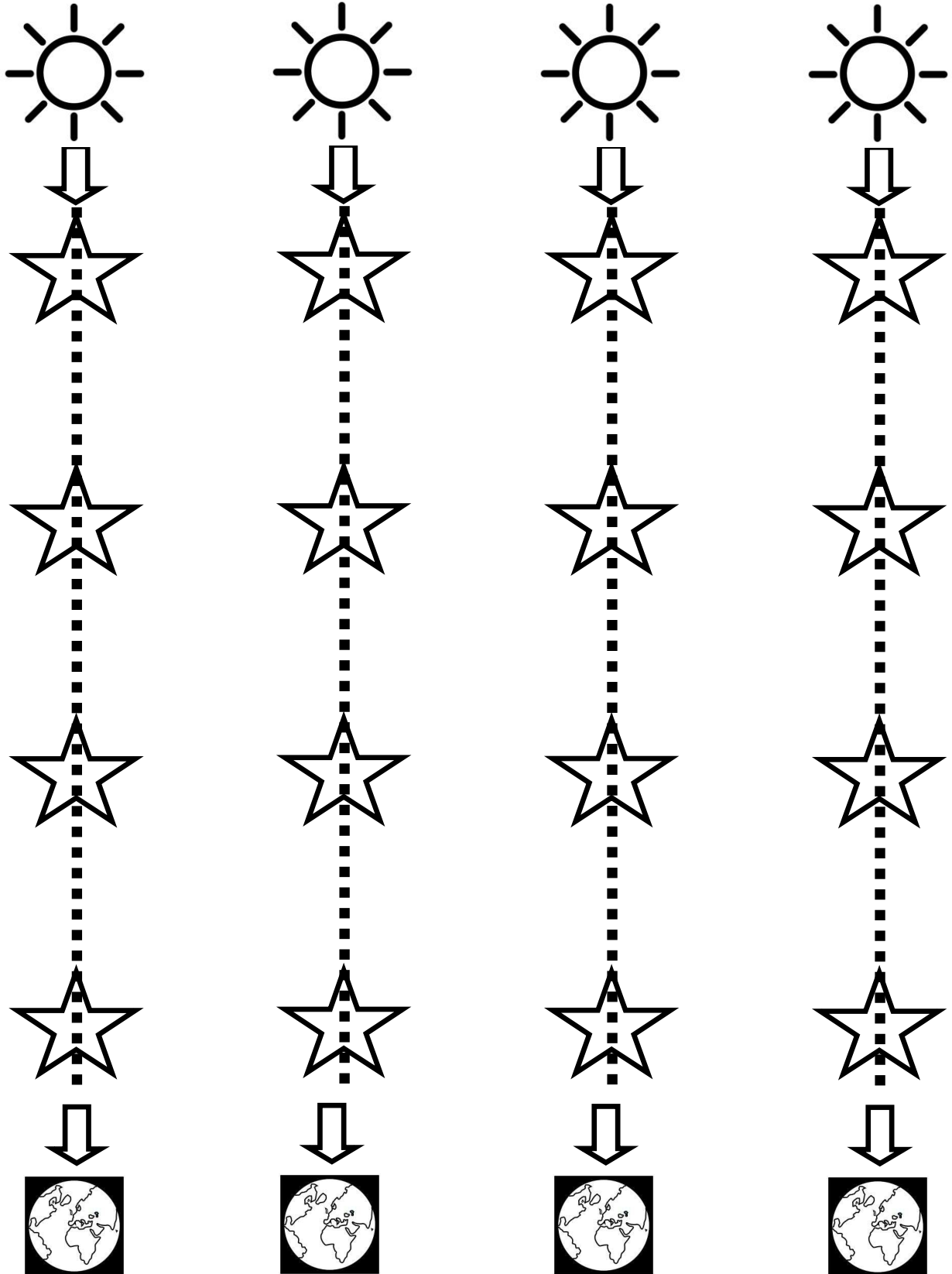



## Actividades para mejorar motricidad fina

Sigue con tu lápiz las estrellitas para ir desde el sol a la tierra

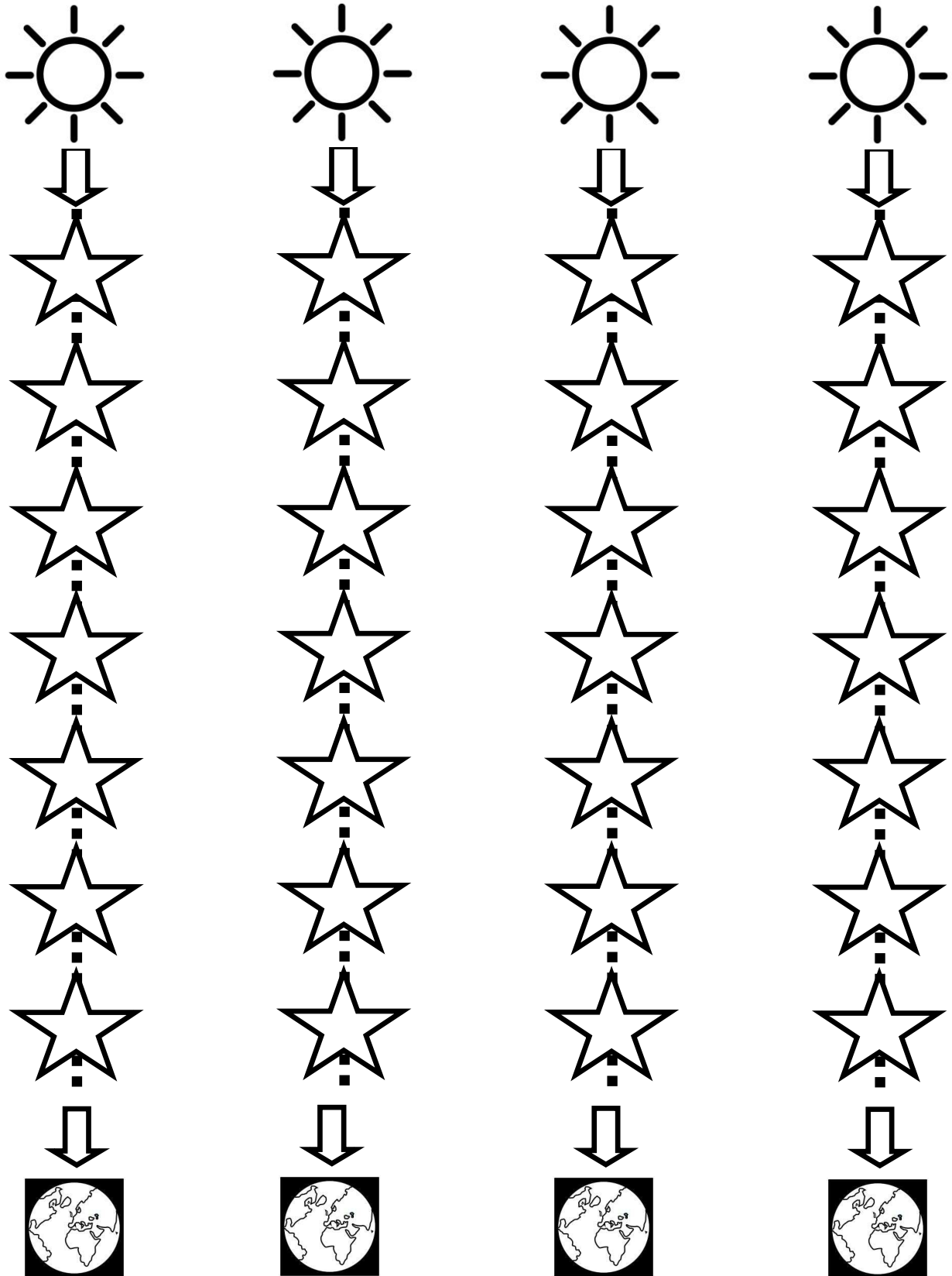

## Actividades para mejorar motricidad fina

Sigue con tu lápiz las estrellitas para ir desde el sol a la tierra

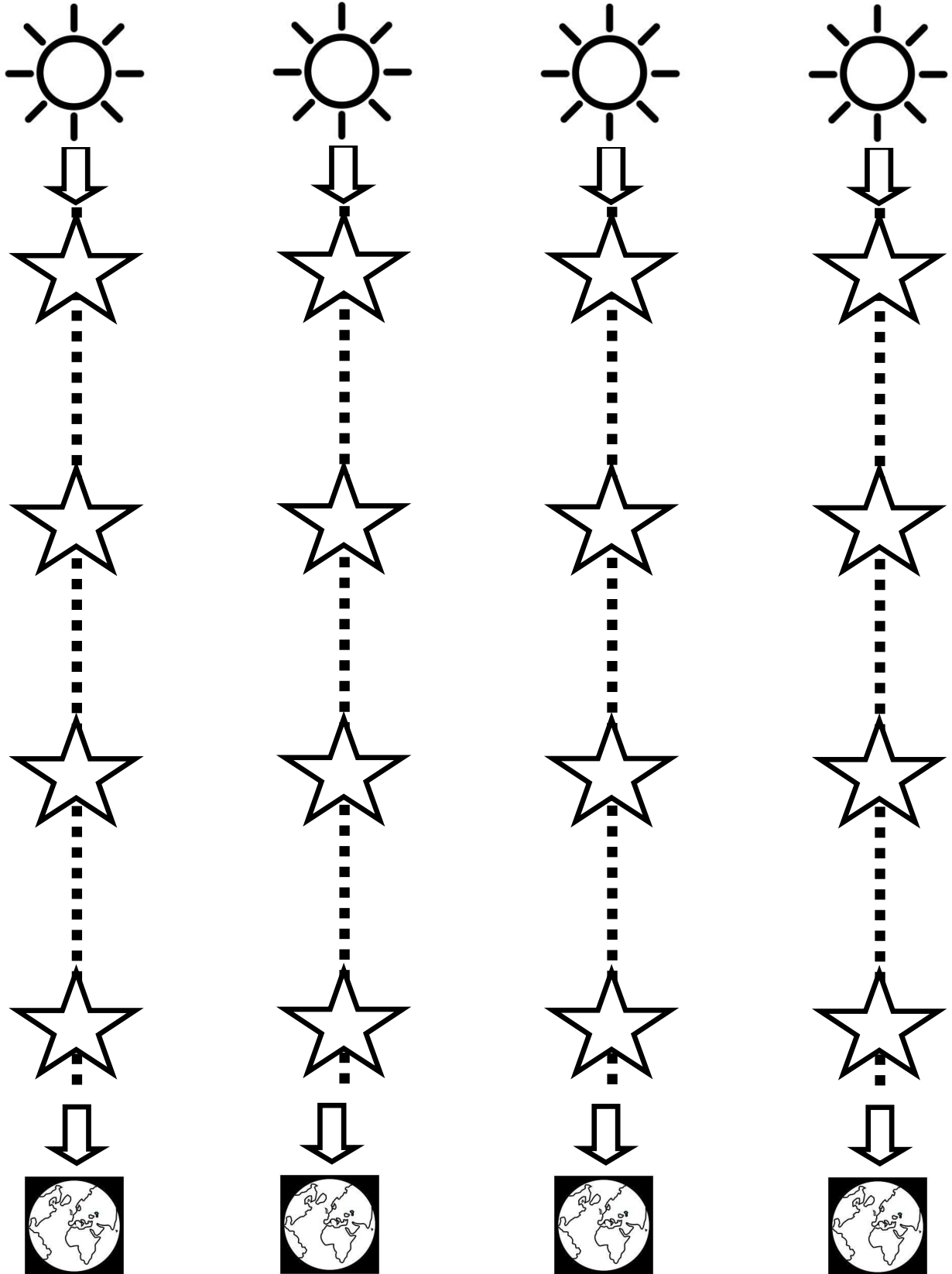

## Actividades para mejorar motricidad fina

Sigue con tu lápiz las estrellitas para ir desde el sol a la tierra

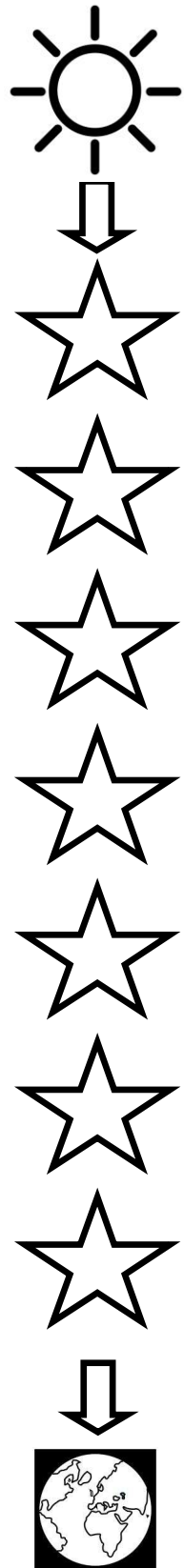
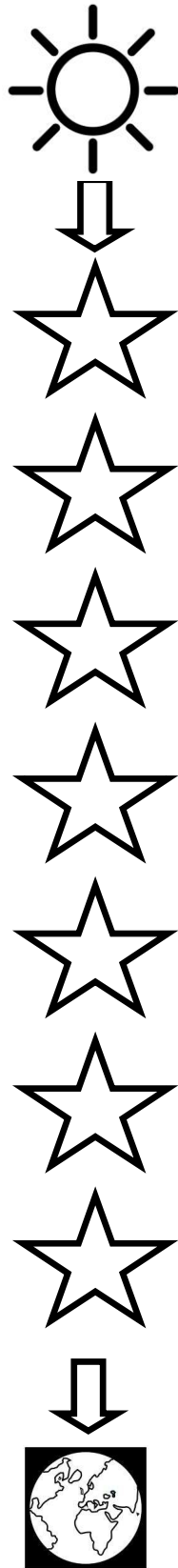
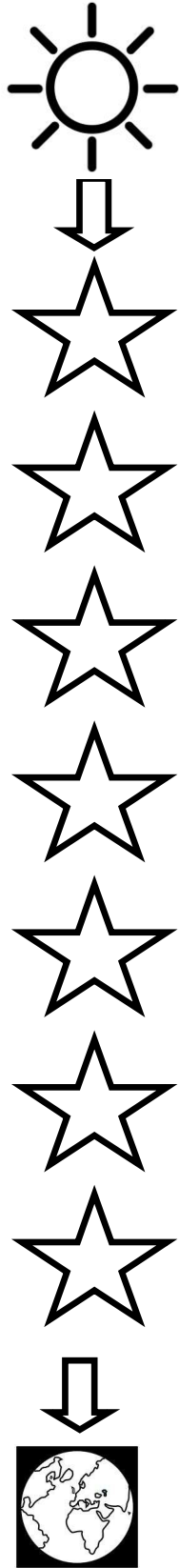
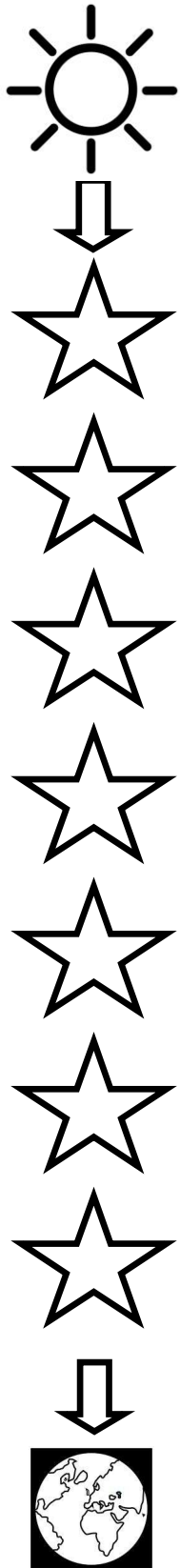

## Actividades para mejorar motricidad fina

Sigue con tu lápiz las estrellitas para ir desde el sol a la tierra

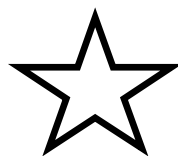
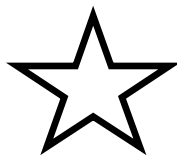
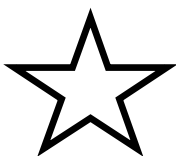
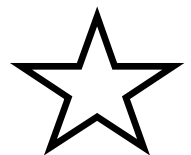
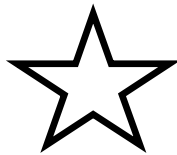
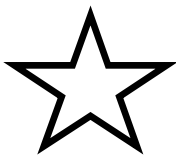
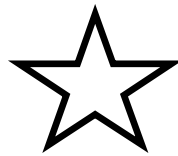
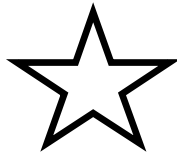
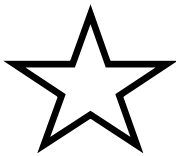
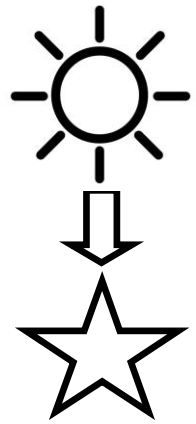
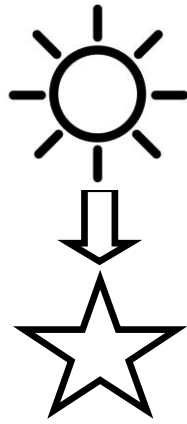
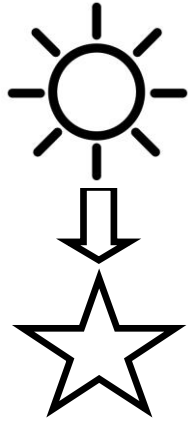
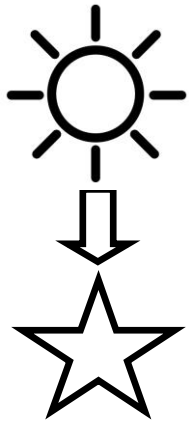

## Actividades para mejorar motricidad fina

Sigue con tu lápiz los corazones para unir a la mama y a su bebe

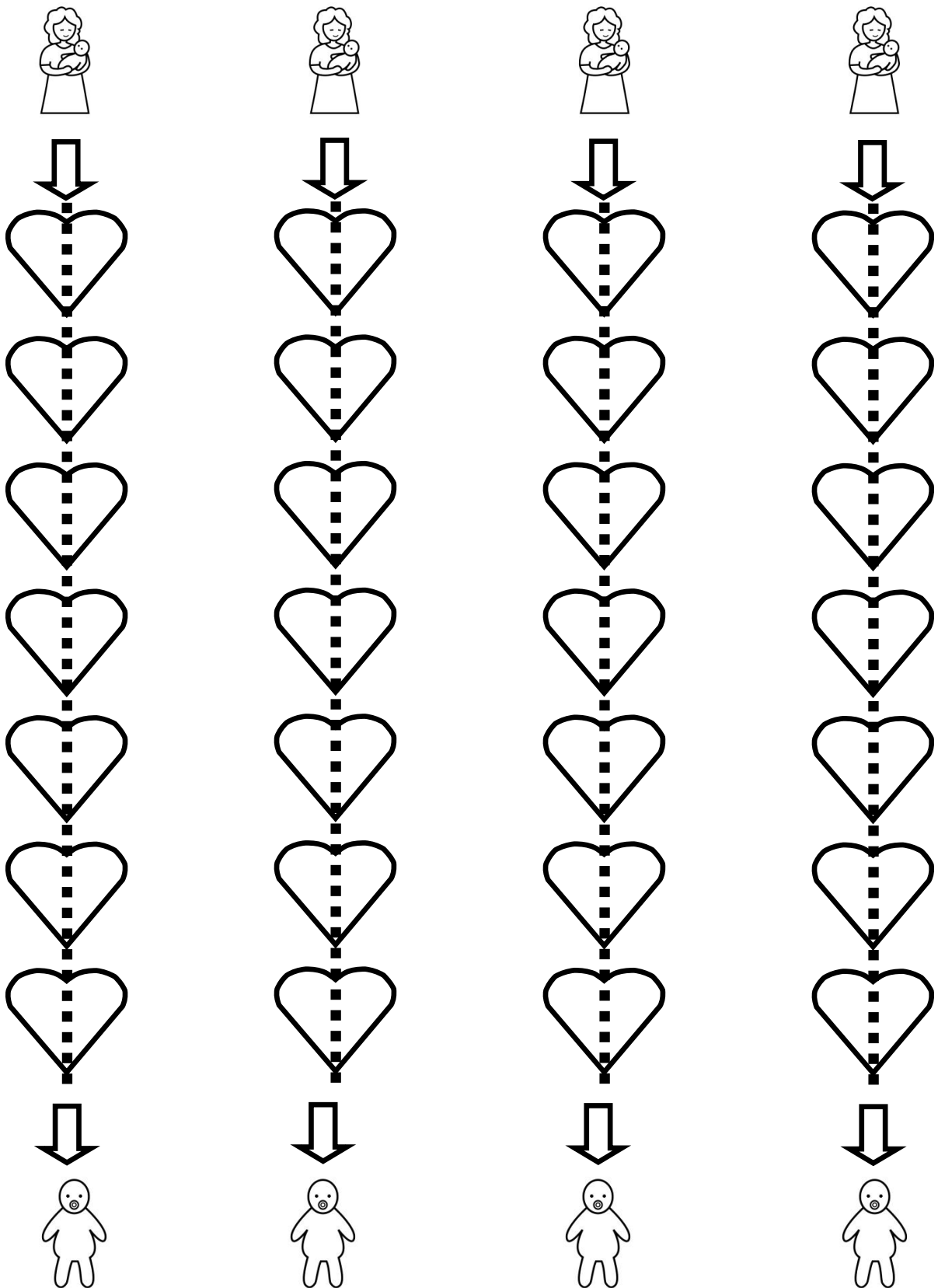

## Actividades para mejorar motricidad fina

Sigue con tu lápiz los corazones para unir a la mama y a su bebe

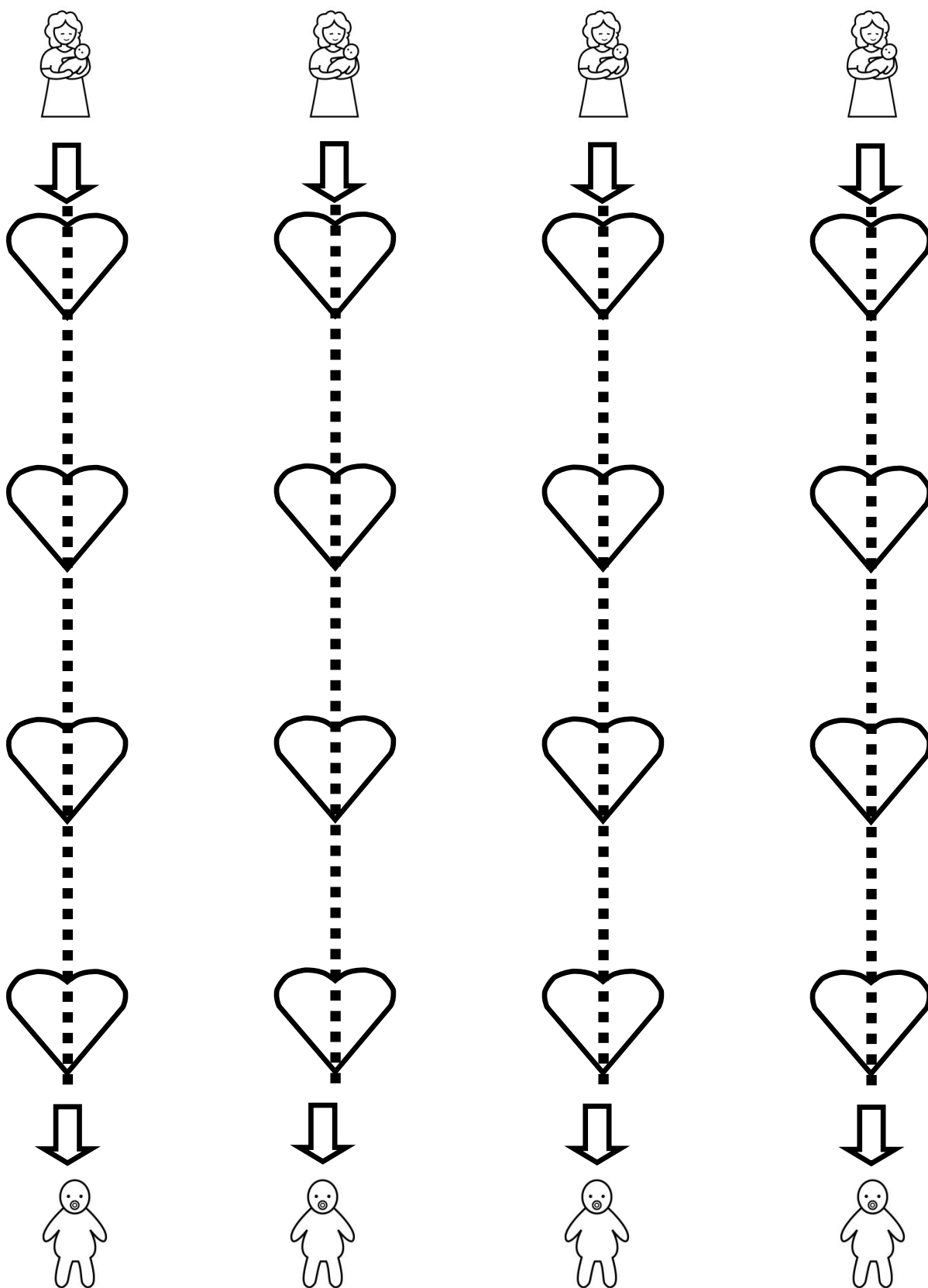

## Actividades para mejorar motricidad fina

Sigue con tu lápiz los corazones para unir a la mama y a su bebe

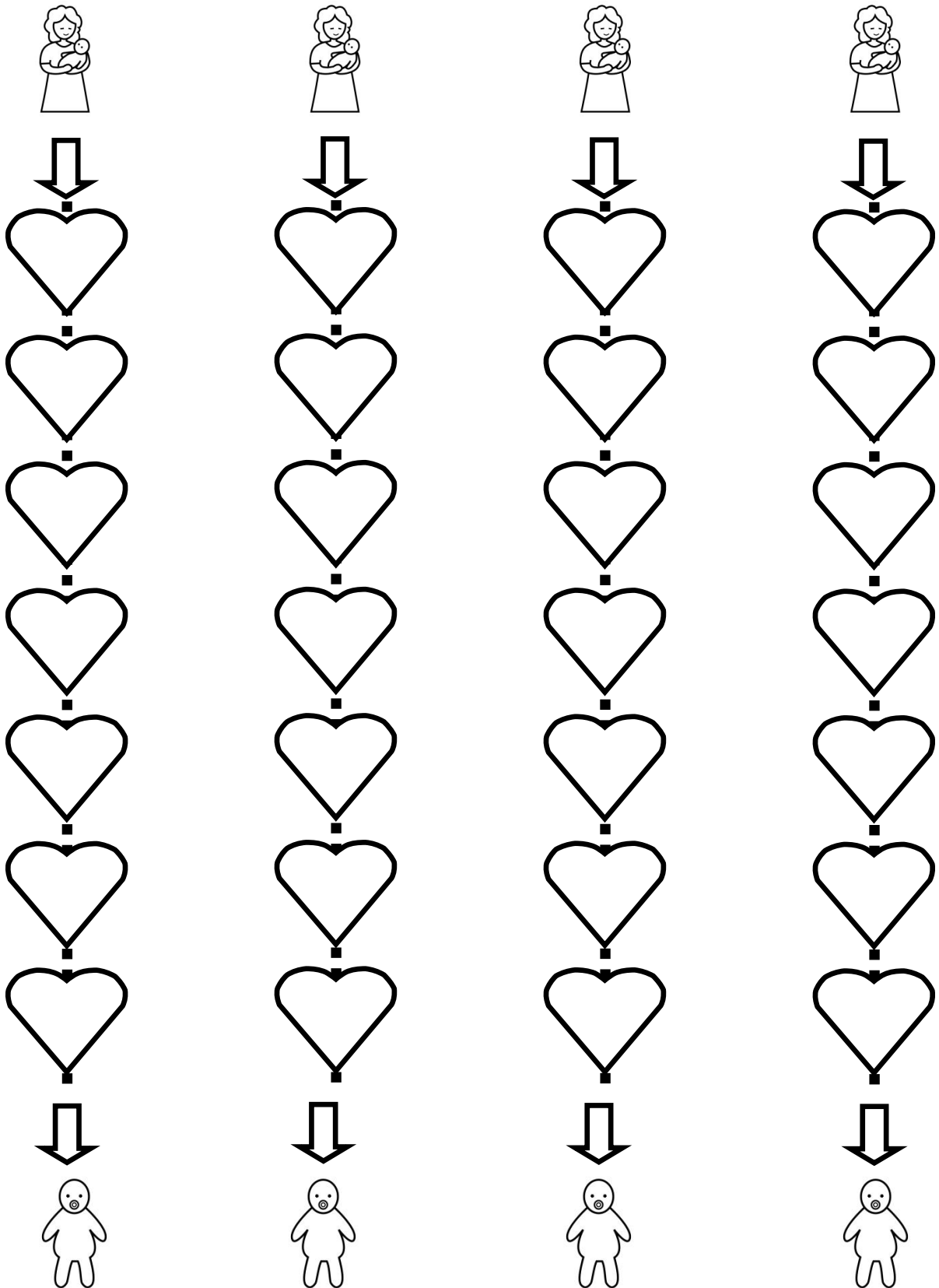

## Actividades para mejorar motricidad fina

Sigue con tu lápiz los corazones para unir a la mama y a su bebe

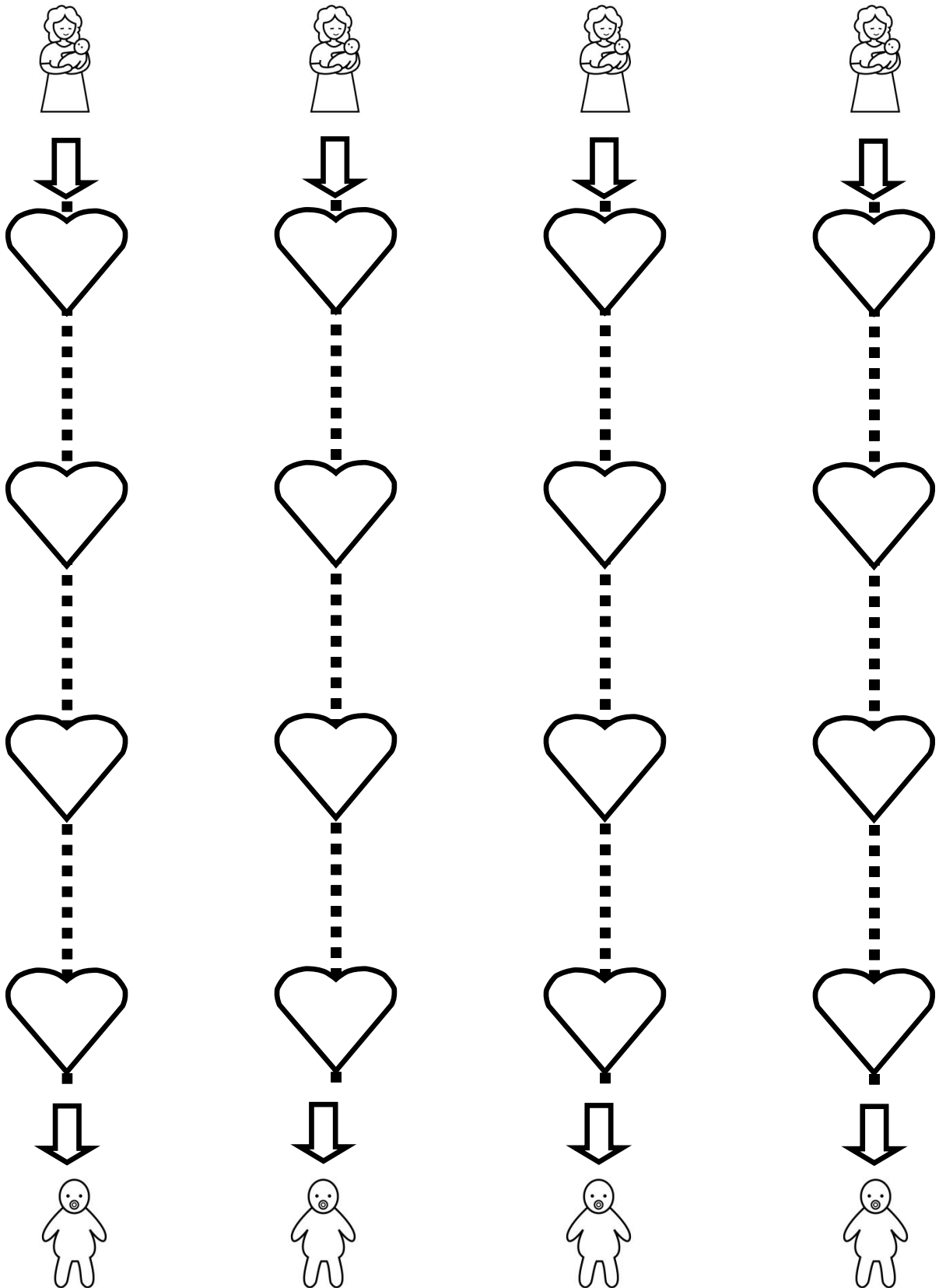



## Actividades para mejorar motricidad fina

Sigue con tu lápiz los corazones para unir a la mama y a su bebe

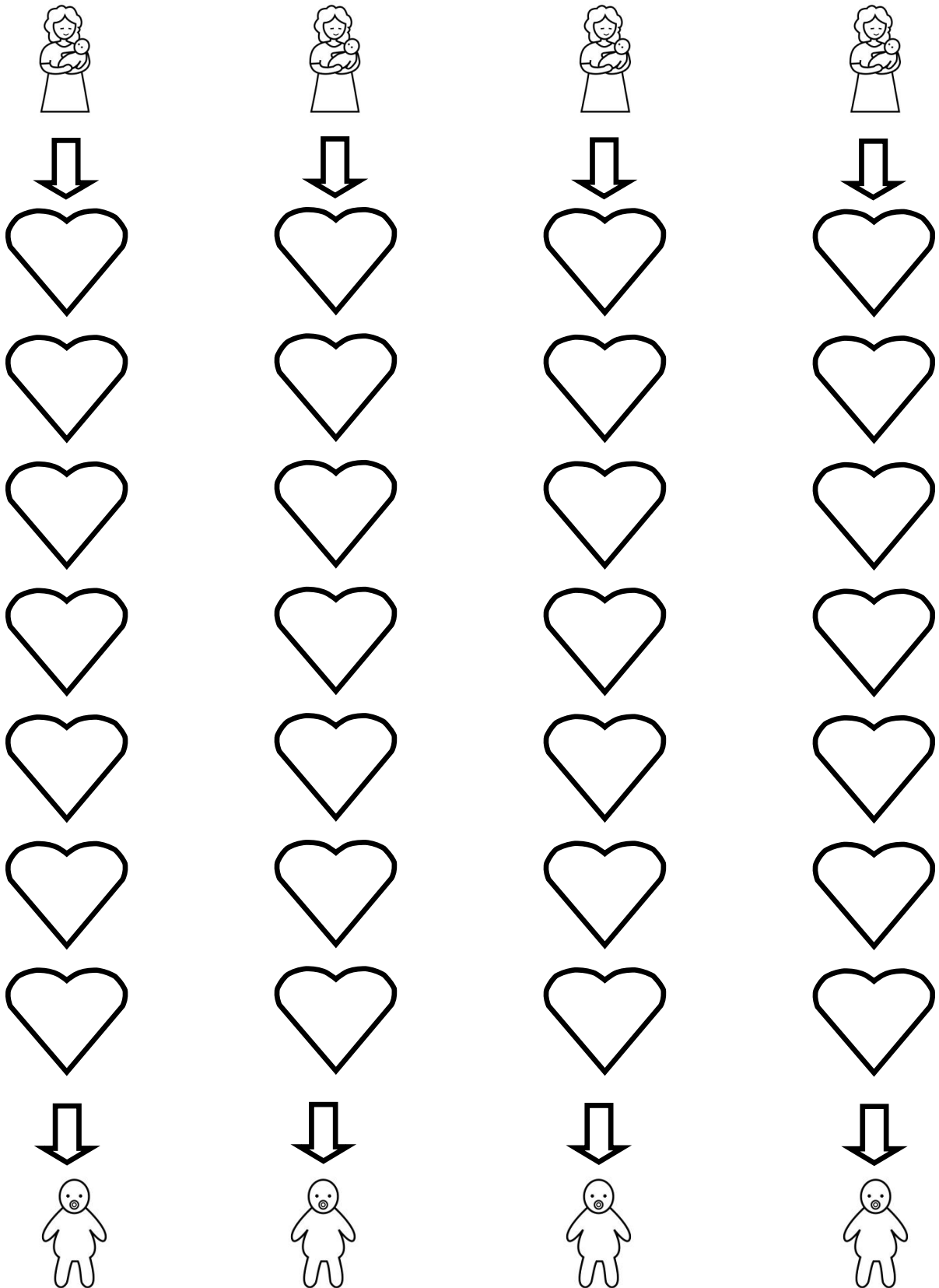

## Actividades para mejorar motricidad fina

Sigue con tu lápiz los corazones para unir a la mama y a su bebe

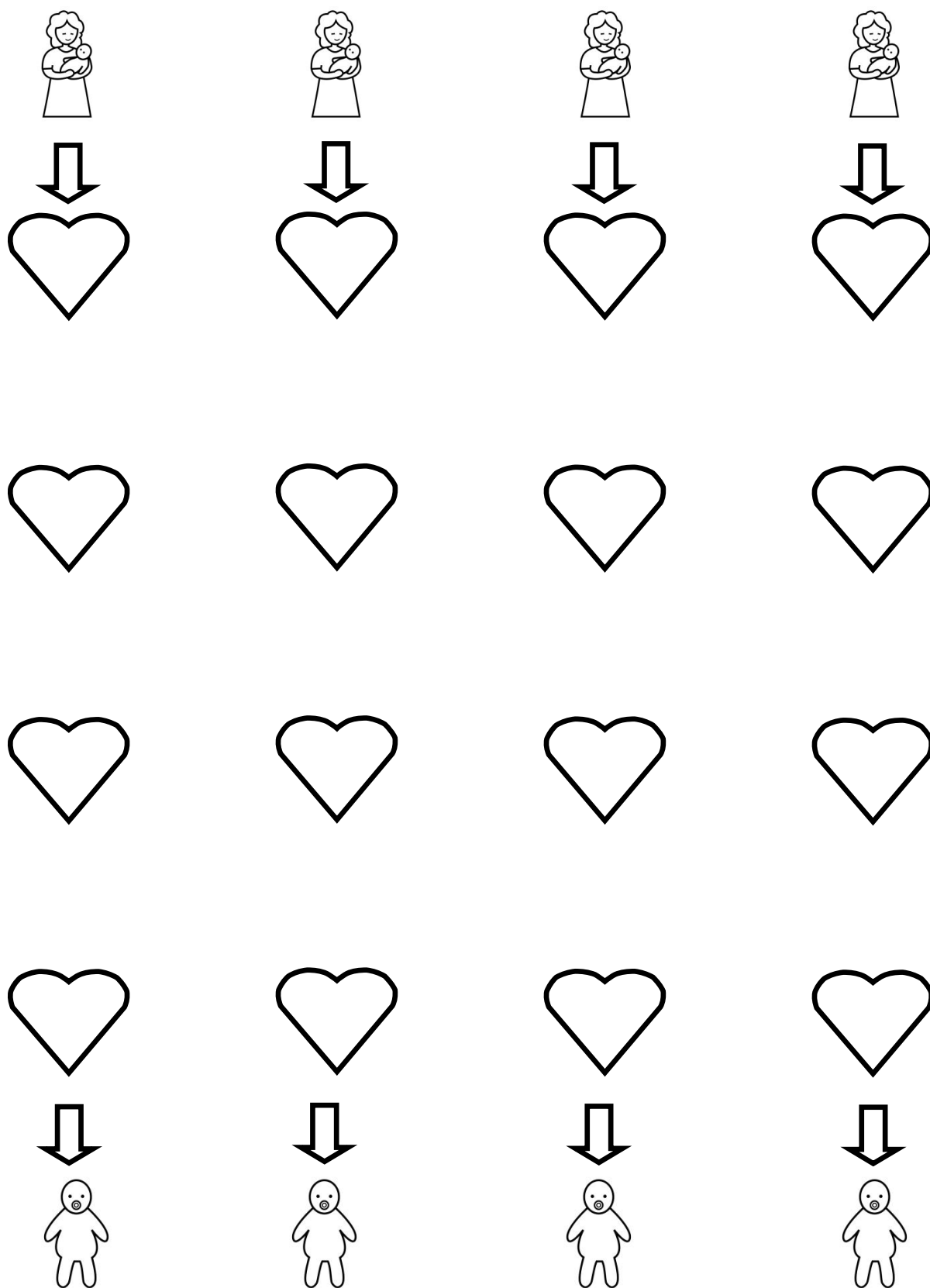

# Actividades para mejorar motricidad fina

Sigue con tu lápiz las caras para unir al niño con su amiga

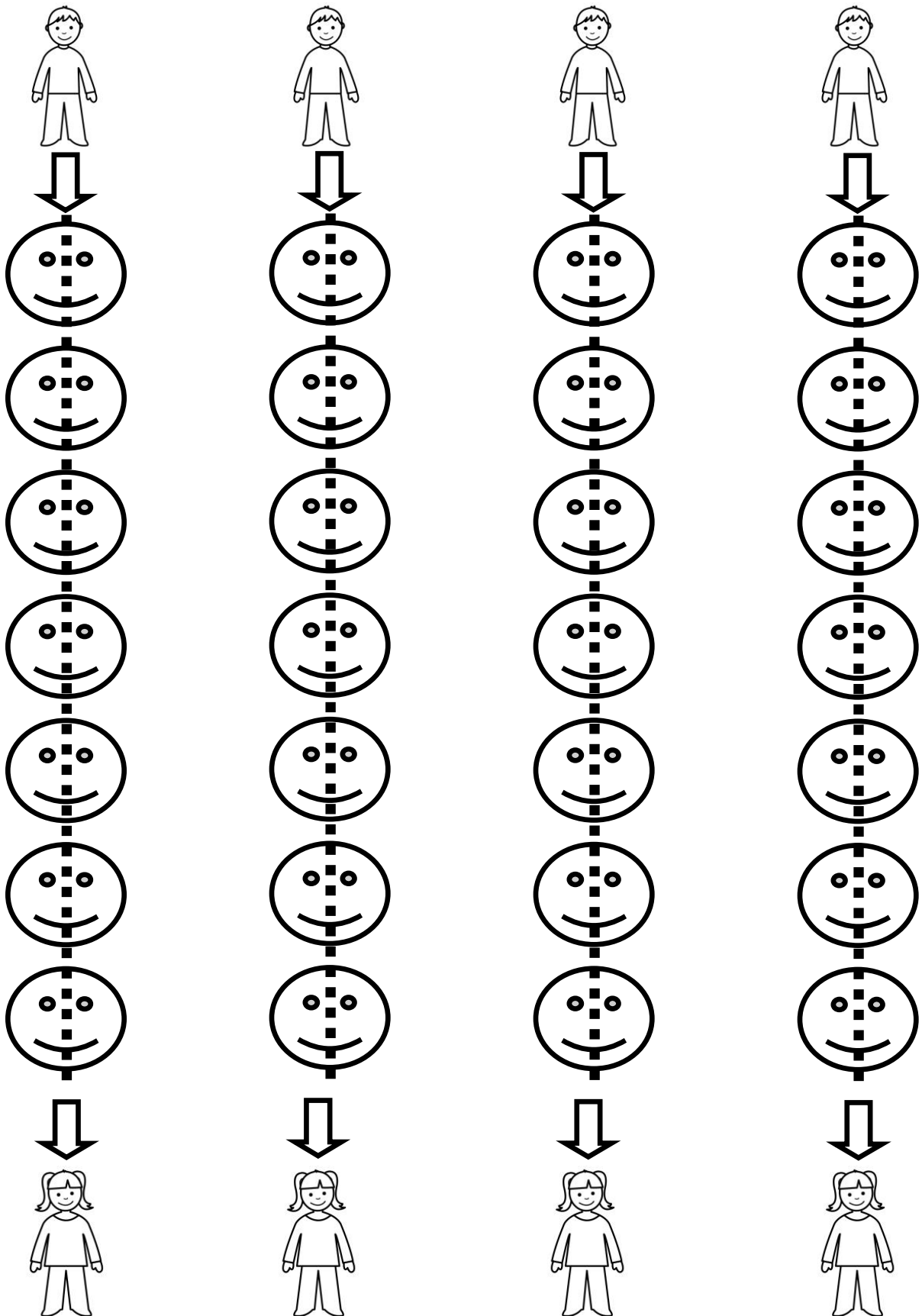

# Actividades para mejorar motricidad fina

Sigue con tu lápiz caras para unir al niño con su amiga

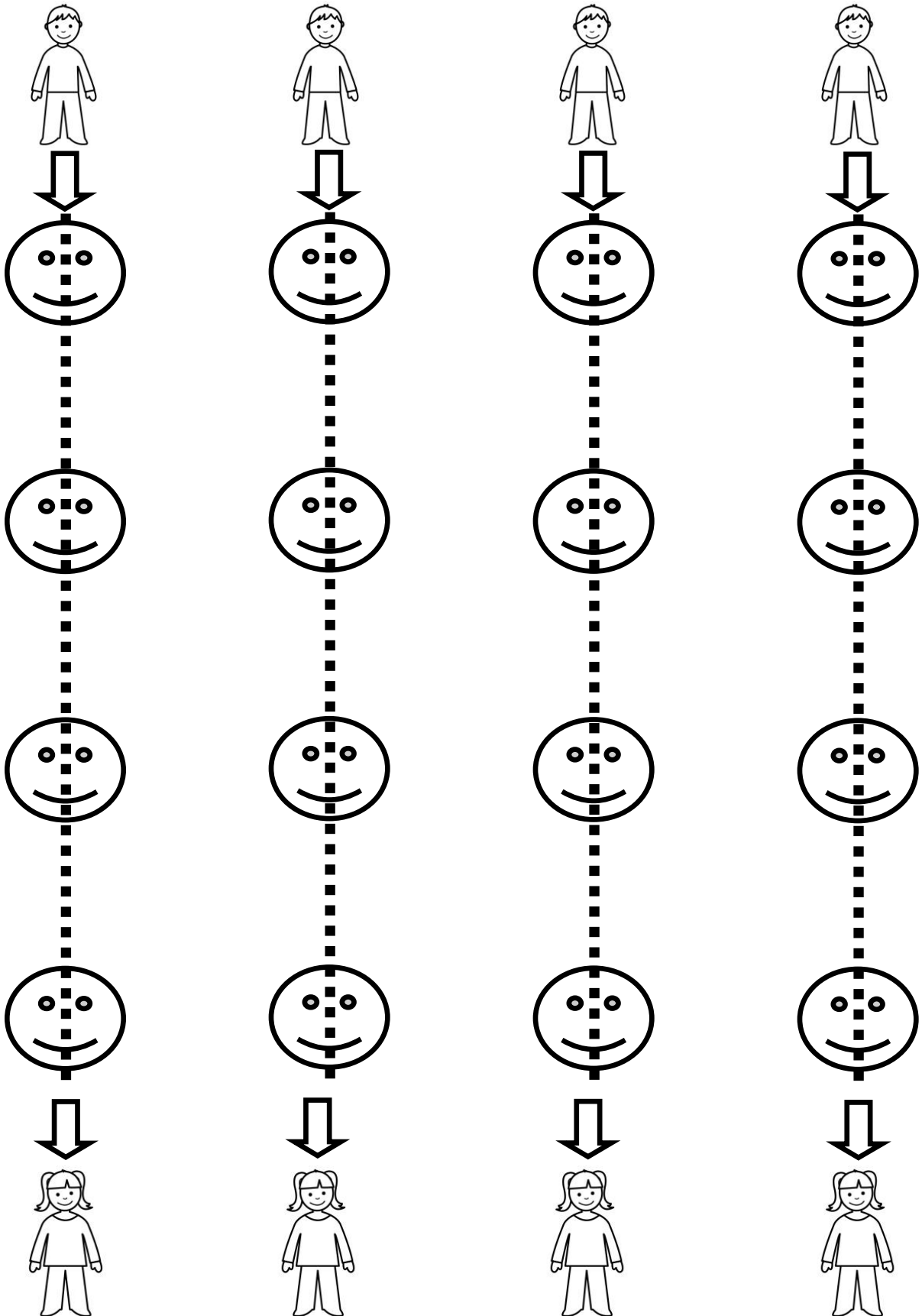

# Actividades para mejorar motricidad fina

Sigue con tu lápiz caras para unir al niño con su amiga

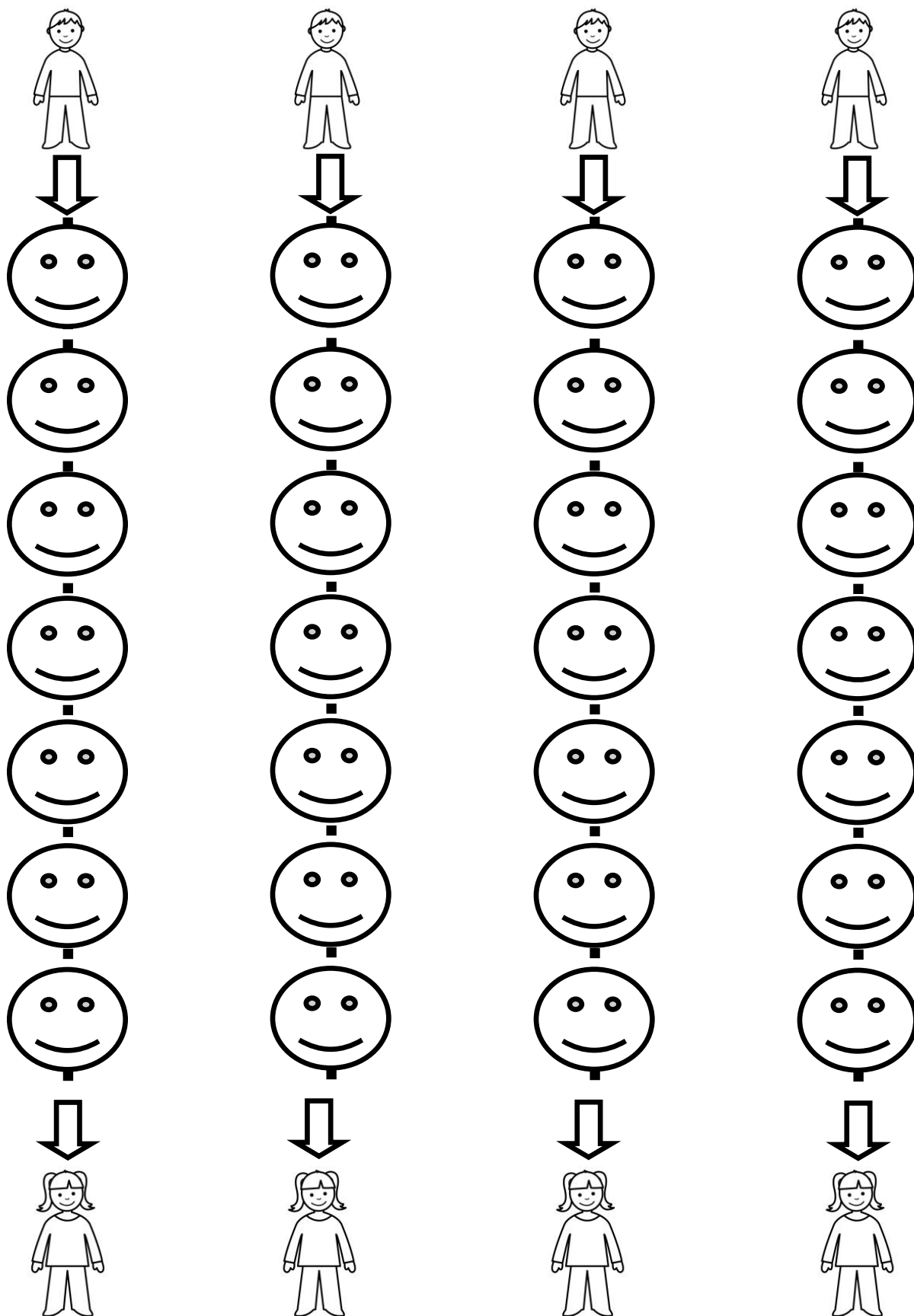

# Actividades para mejorar motricidad fina

Sigue con tu lápiz caras para unir al niño con su amiga

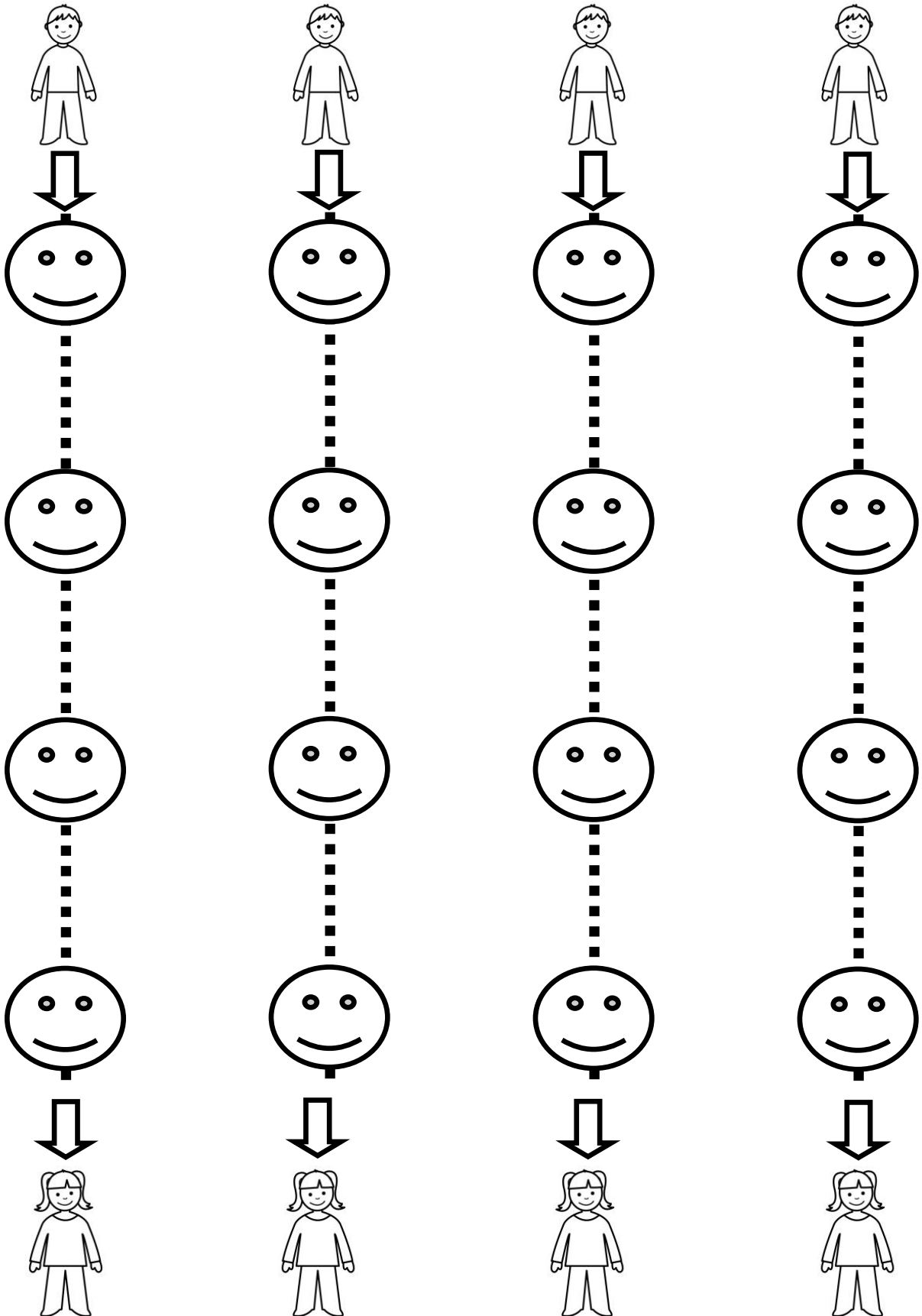

# Actividades para mejorar motricidad fina

Sigue con tu lápiz caras para unir al niño con su amiga

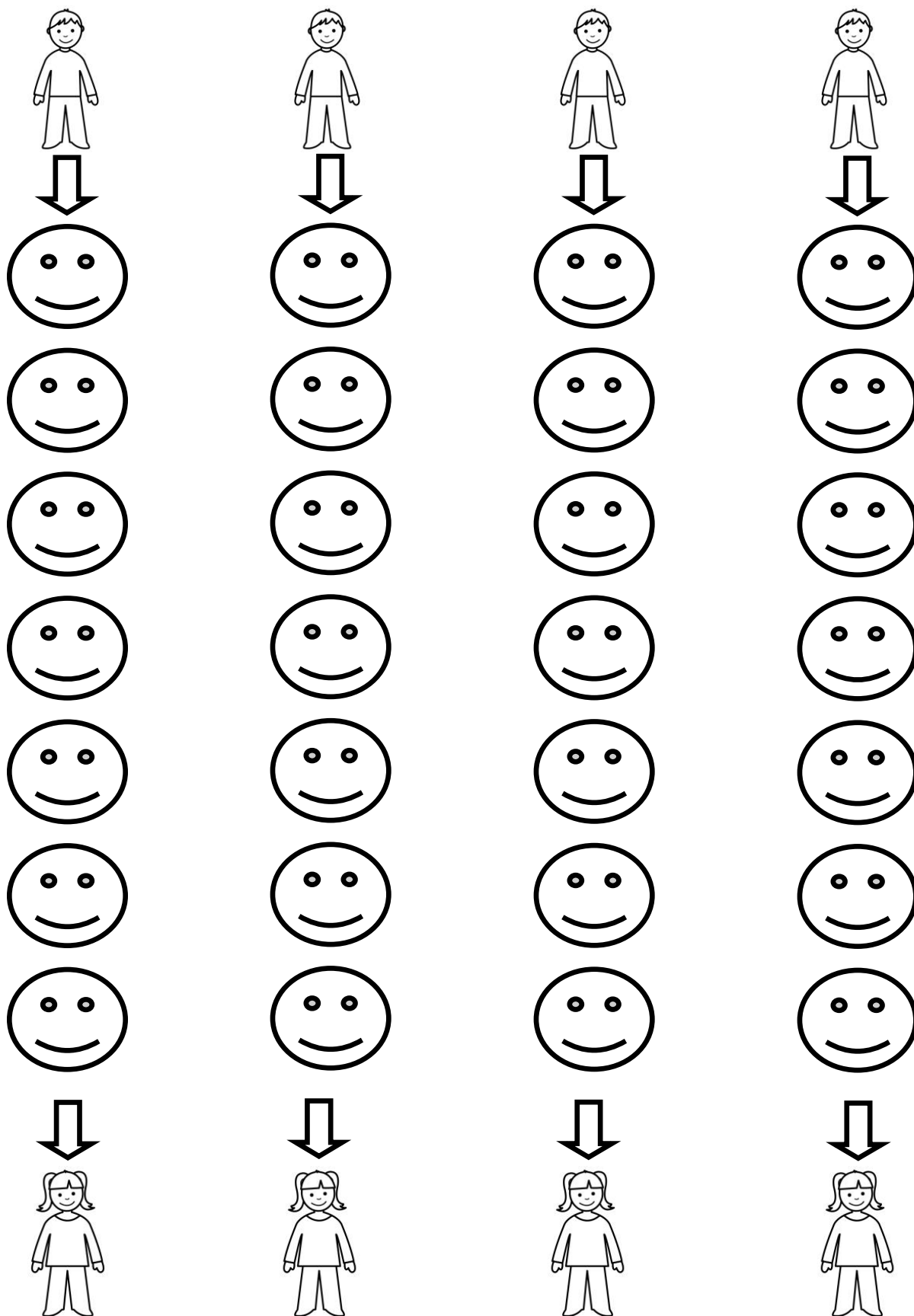

# Actividades para mejorar motricidad fina

Sigue con tu lápiz caras para unir al niño con su amiga

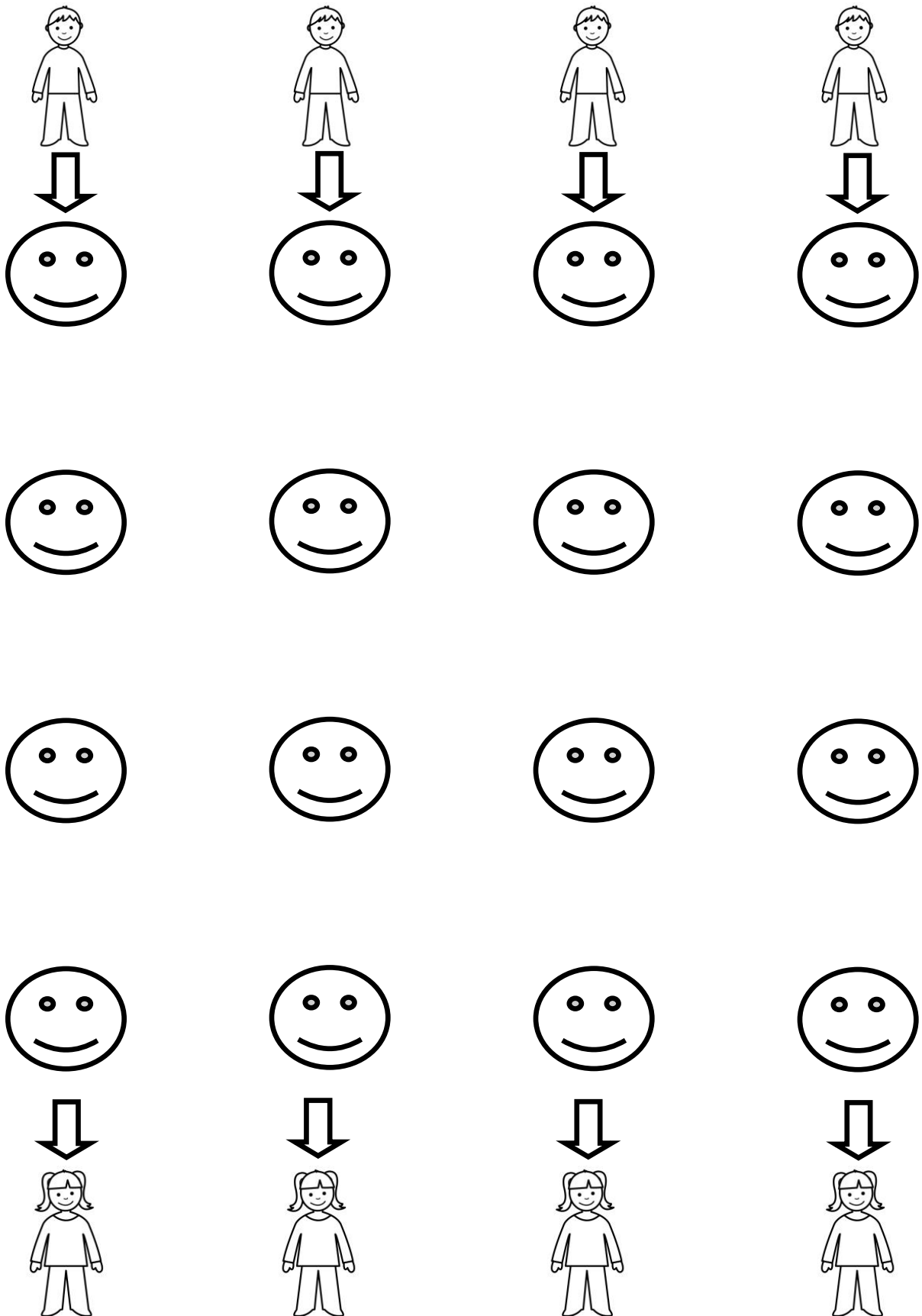



## Actividades para mejorar motricidad fina

Sigue con tu lápiz los círculos para unir al niño con su balón

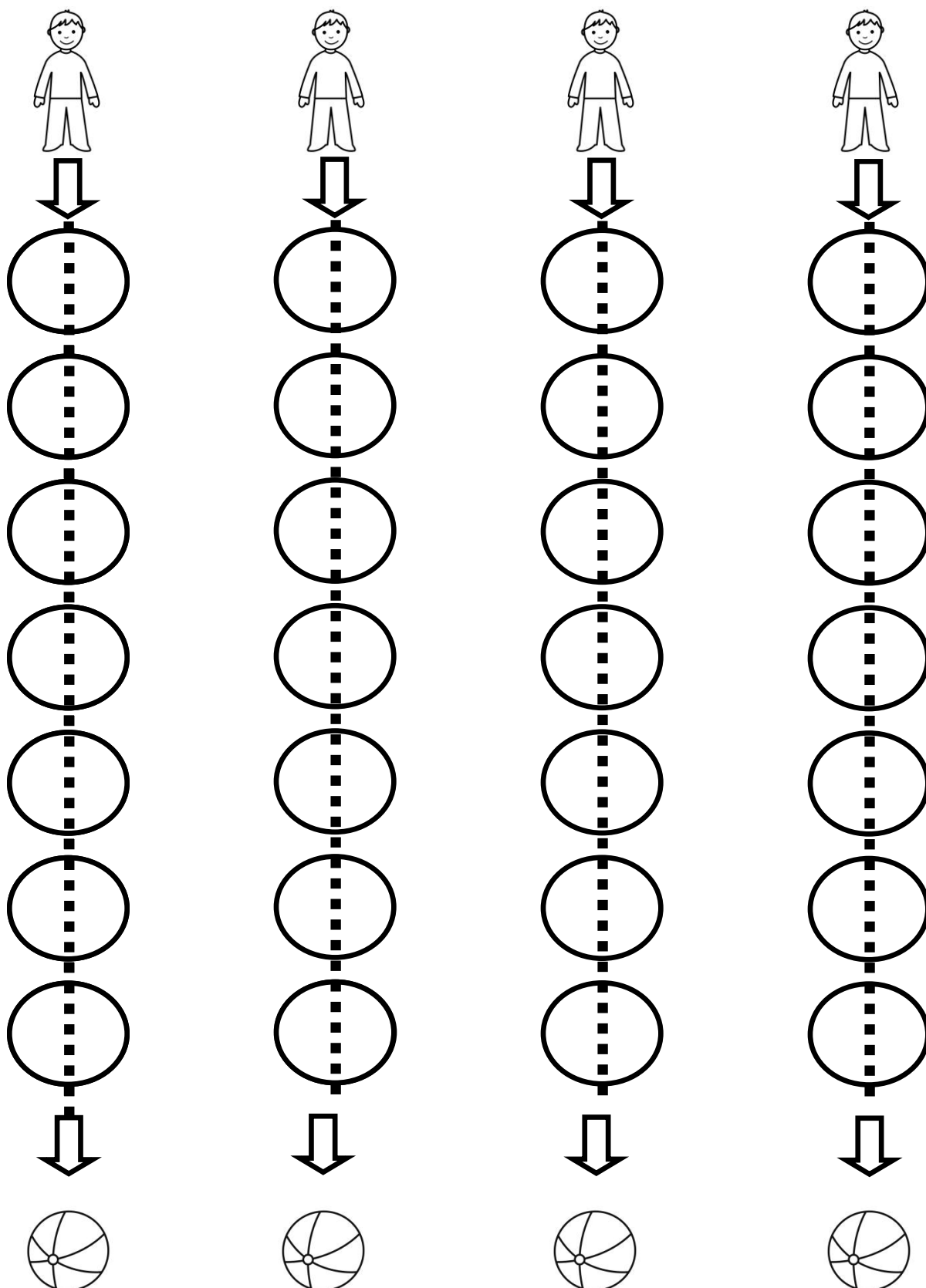

# Actividades para mejorar motricidad fina

Sigue con tu lápiz los círculos para unir al niño con su balón

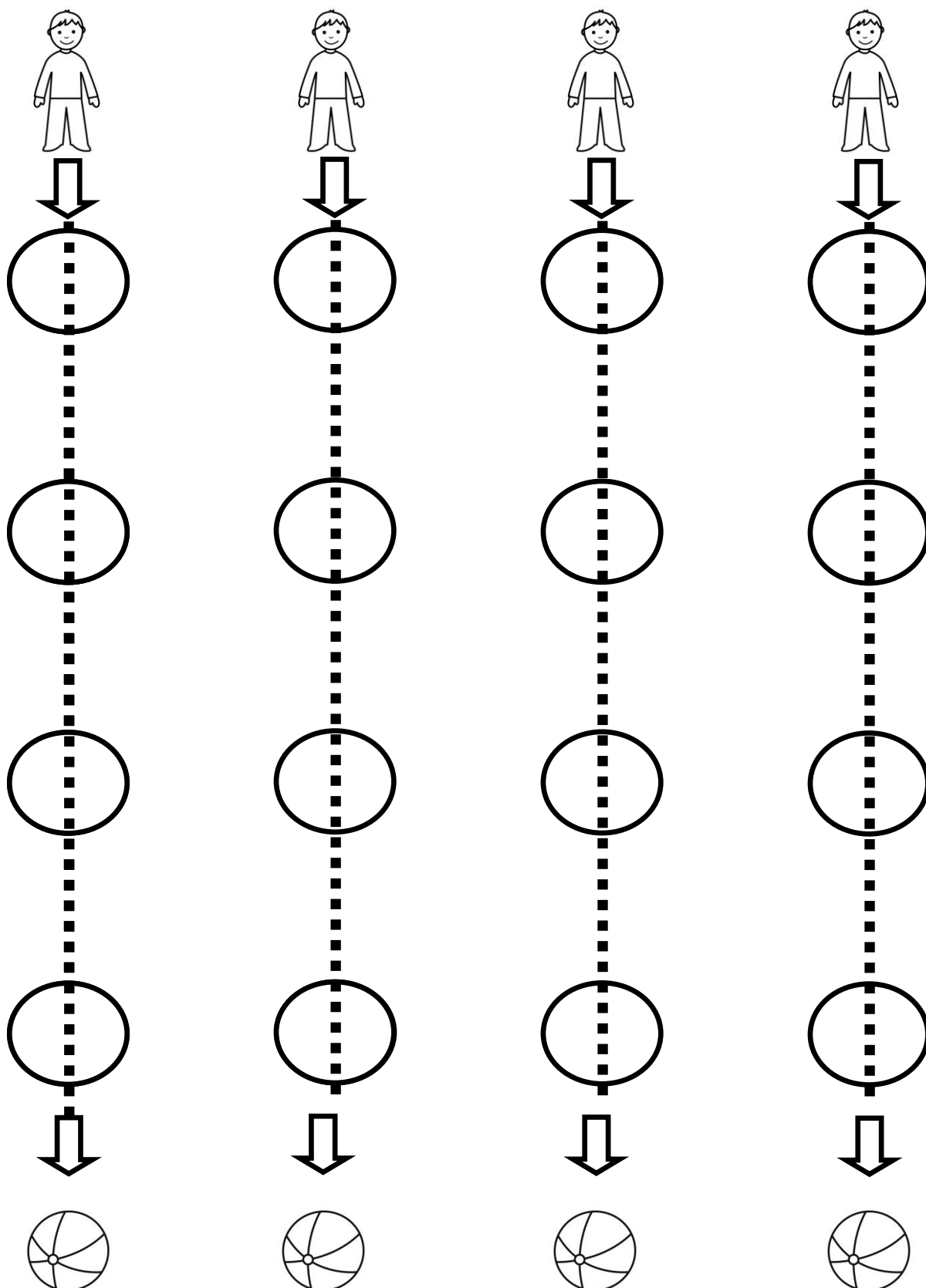

## Actividades para mejorar motricidad fina

Sigue con tu lápiz los círculos para unir al niño con su balón

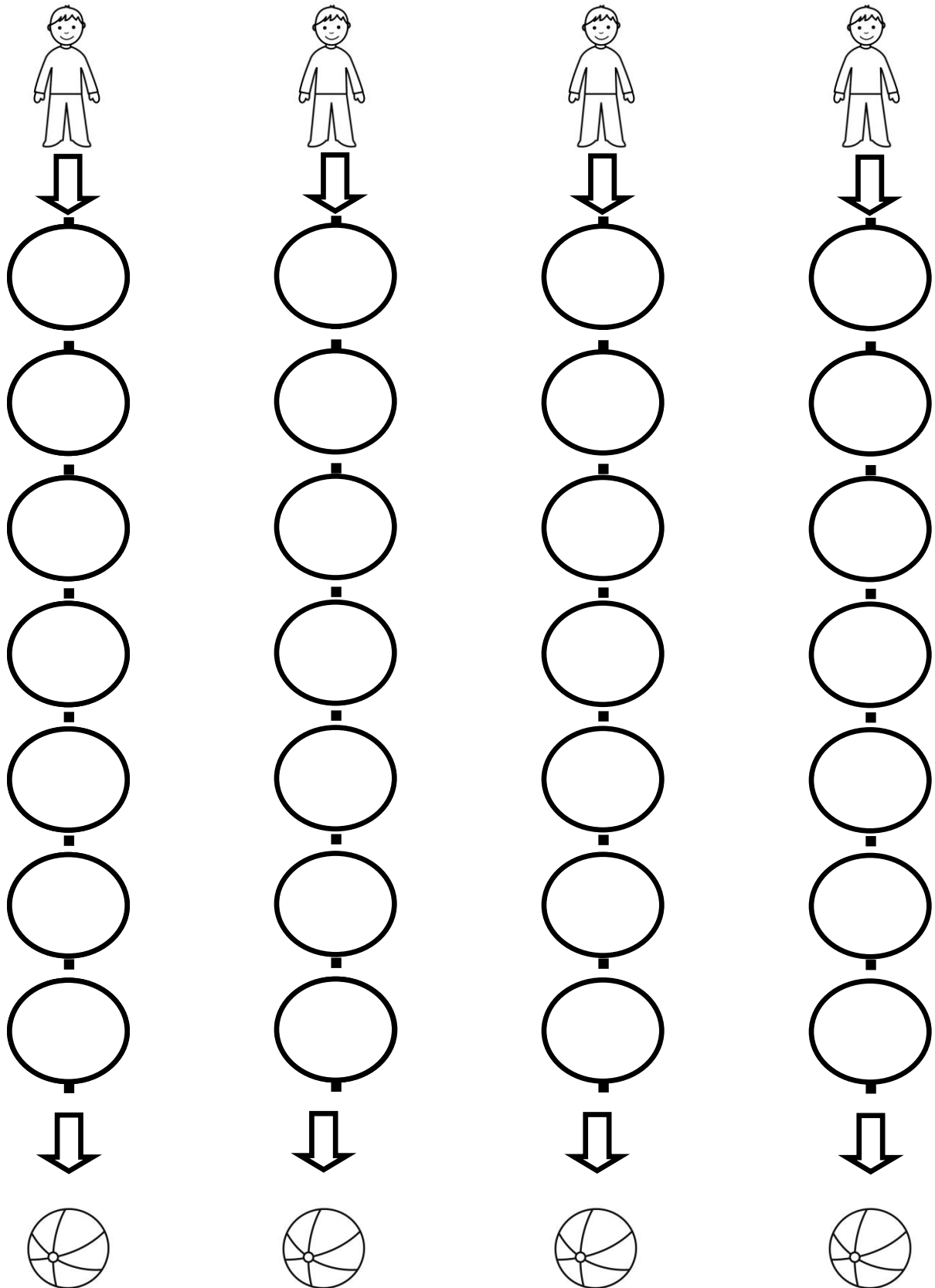

## Actividades para mejorar motricidad fina

Sigue con tu lápiz los círculos para unir al niño con su balón

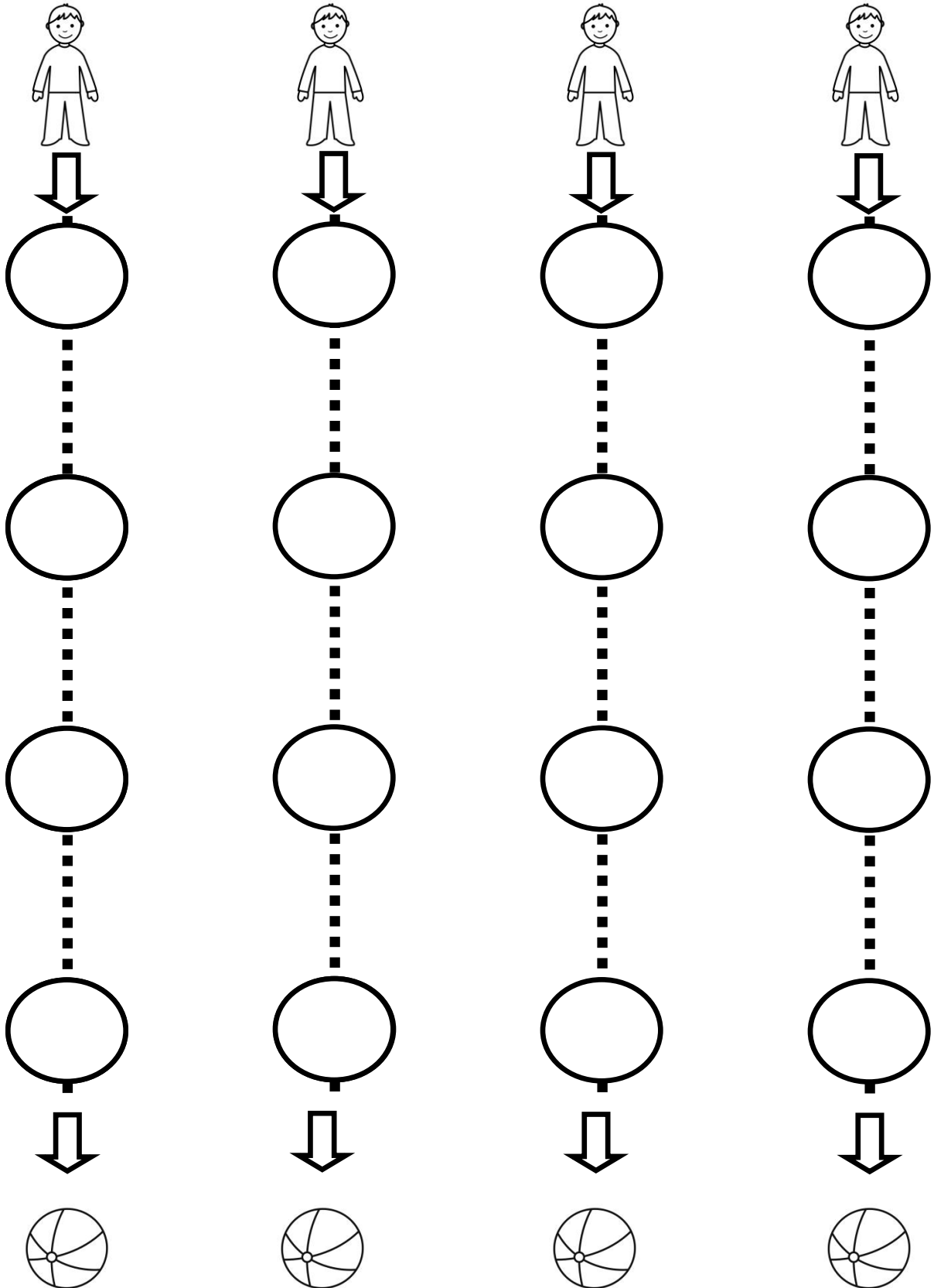

# Actividades para mejorar motricidad fina

Sigue con tu lápiz los círculos para unir al niño con su balón

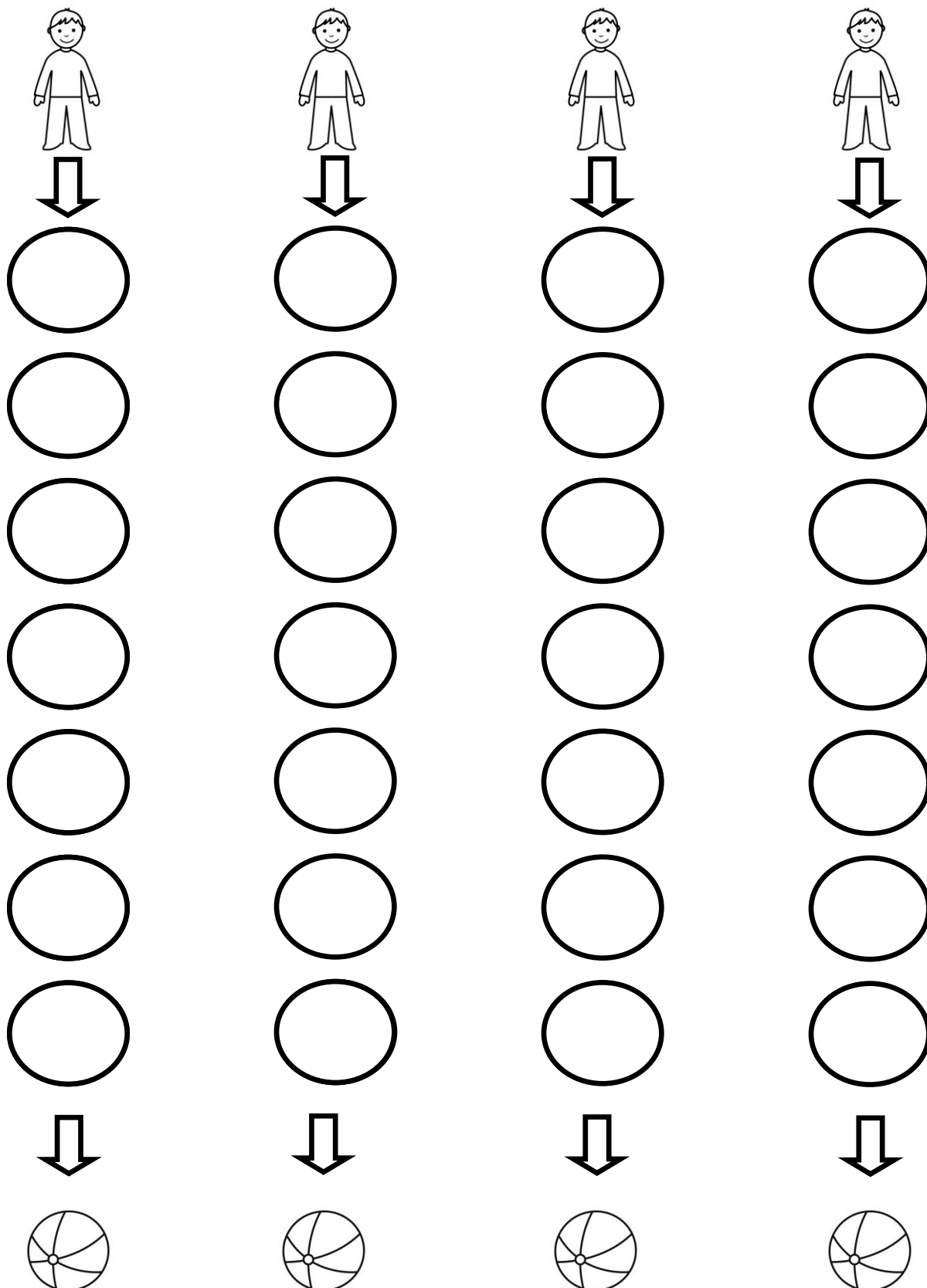

# Actividades para mejorar motricidad fina

Sigue con tu lápiz los círculos para unir al niño con su balón

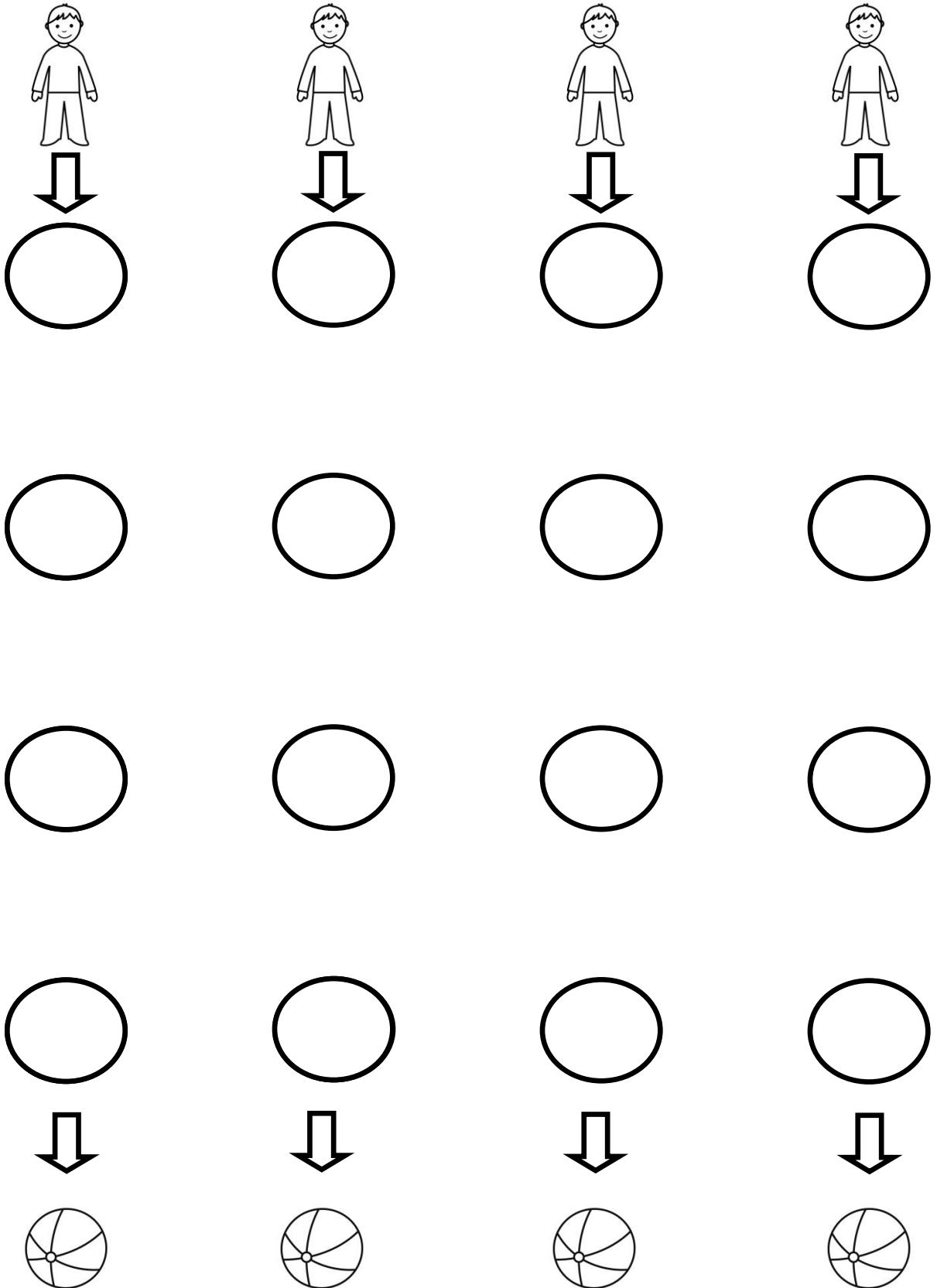

# Actividades para mejorar motricidad fina

Sigue con tu lápiz los rayos para unir a nube y la tierra

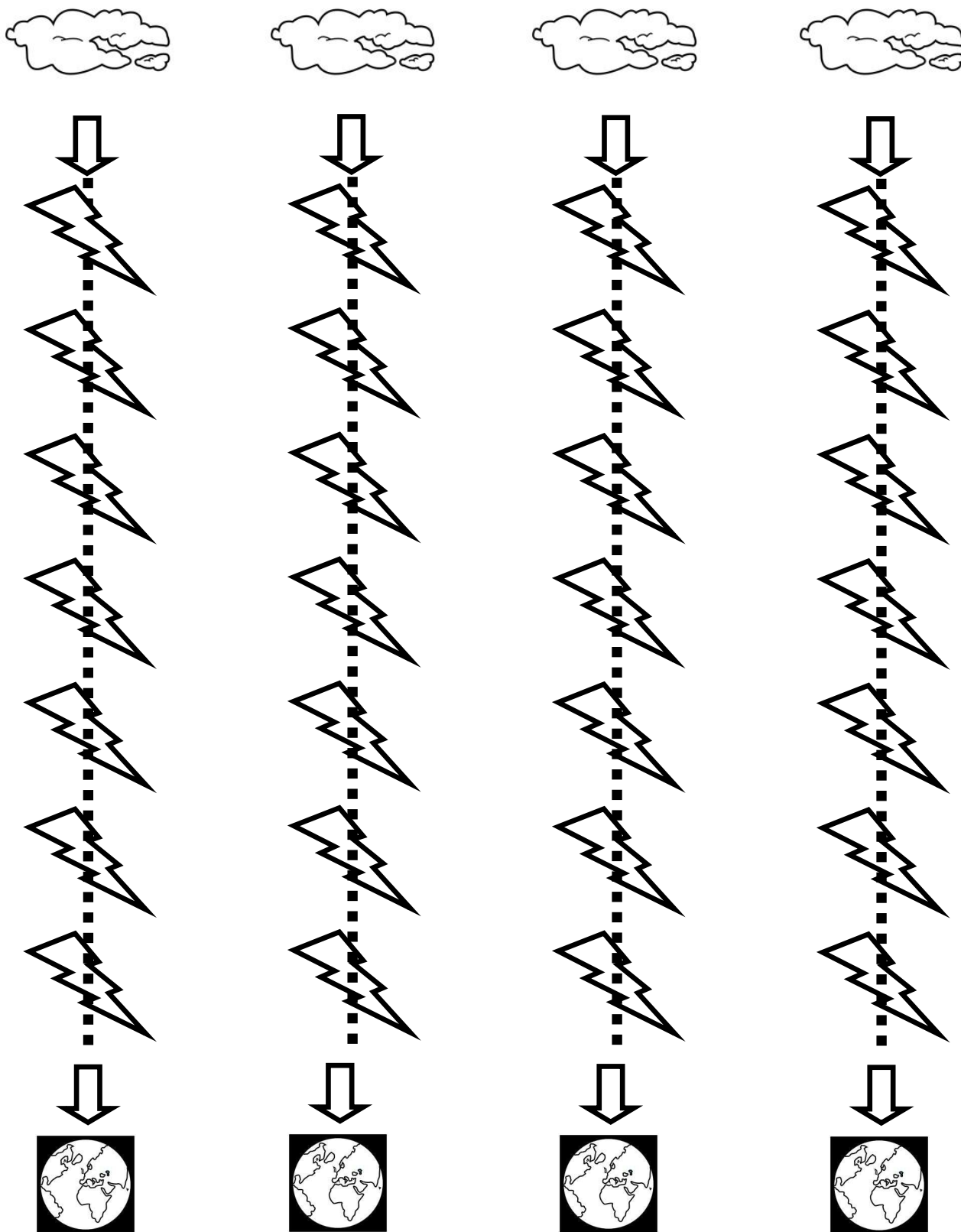

# Actividades para mejorar motricidad fina

Sigue con tu lápiz los rayos para unir a nube y la tierra

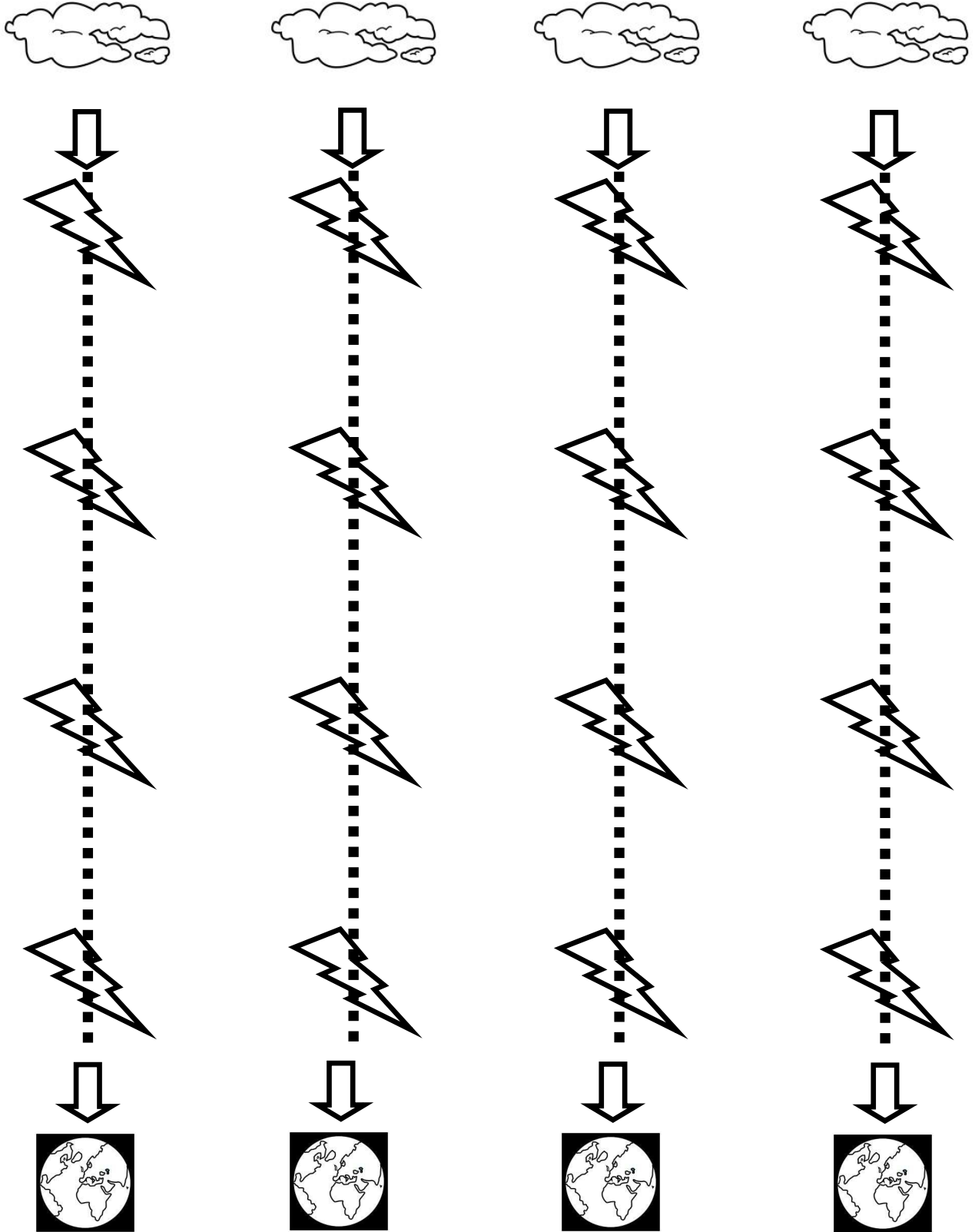



# Actividades para mejorar motricidad fina

Sigue con tu lápiz los rayos para unir a nube y la tierra

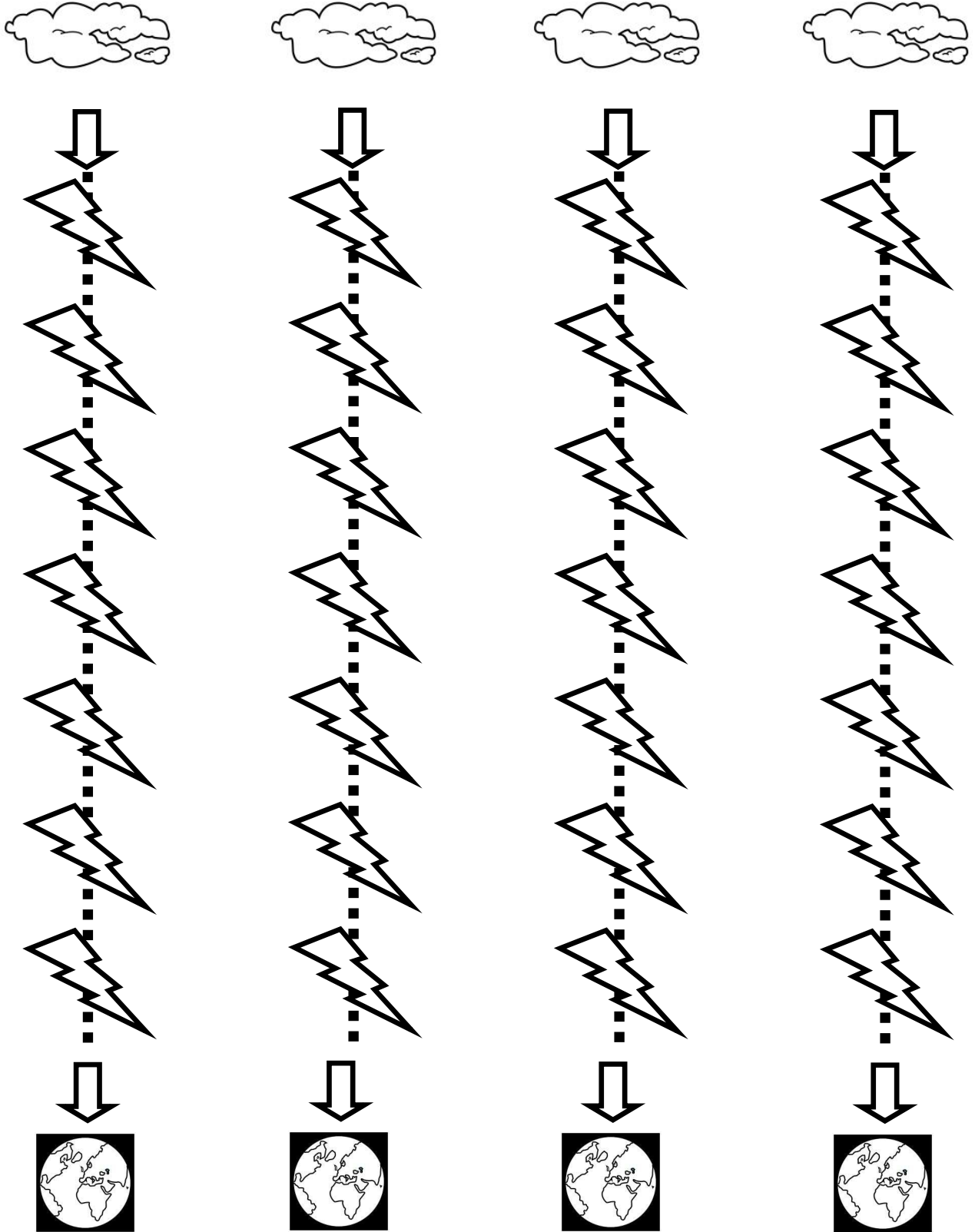

# Actividades para mejorar motricidad fina

Sigue con tu lápiz los rayos para unir a nube y la tierra

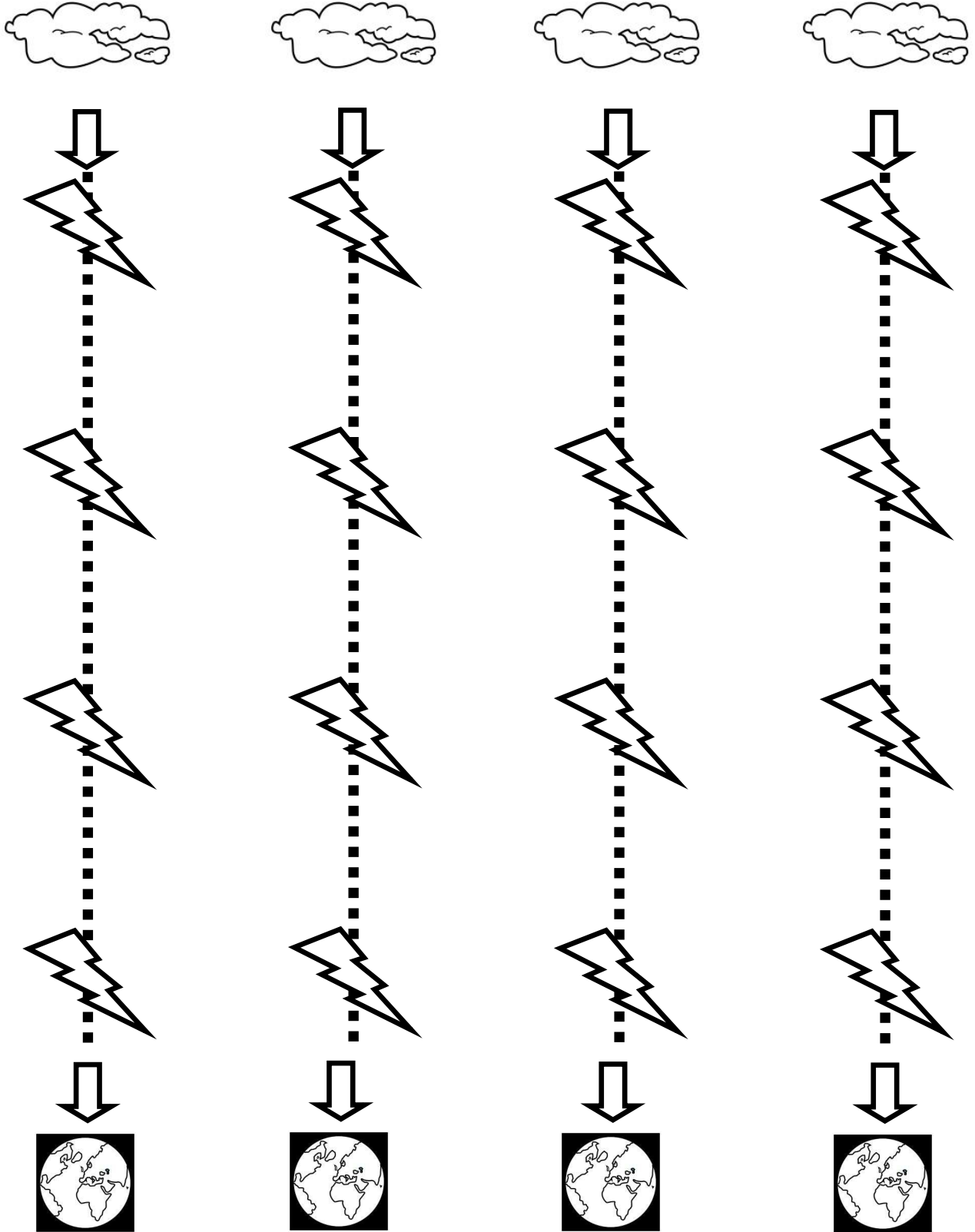

# Actividades para mejorar motricidad fina

Sigue con tu lápiz los rayos para unir a nube y la tierra

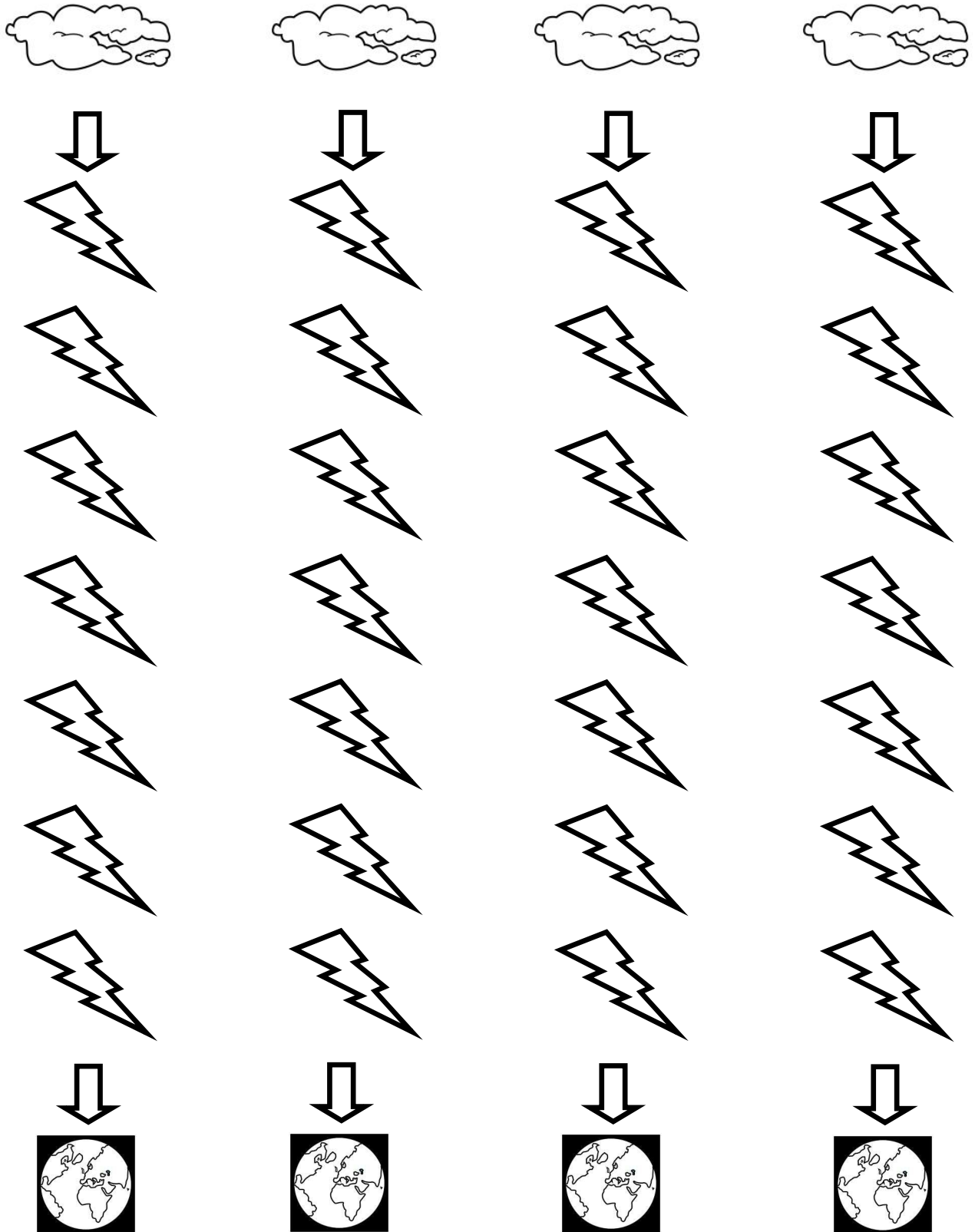

# Actividades para mejorar motricidad fina

Sigue con tu lápiz los rayos para unir a nube y la tierra

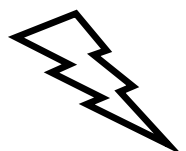
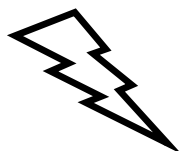
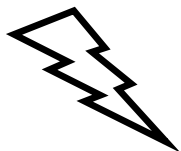
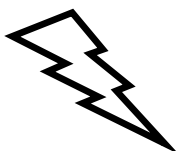
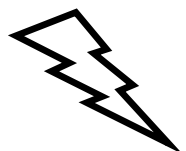
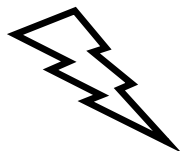
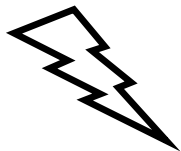
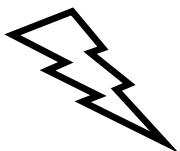
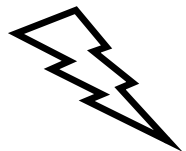
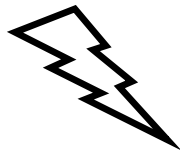
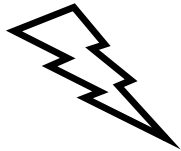
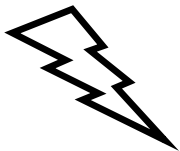
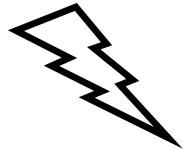
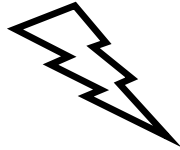
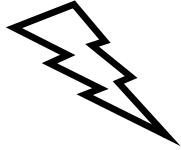
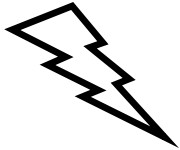

## Actividades para mejorar motricidad fina

Sigue con tu lápiz las estrellitas para ir desde el sol a la tierra



## Actividades para mejorar motricidad fina

Sigue con tu lápiz las estrellitas para ir desde el sol a la tierra



## Actividades para mejorar motricidad fina

Sigue con tu lápiz las estrellitas para ir desde el sol a la tierra



## Actividades para mejorar motricidad fina

Sigue con tu lápiz las estrellitas para ir desde el sol a la tierra

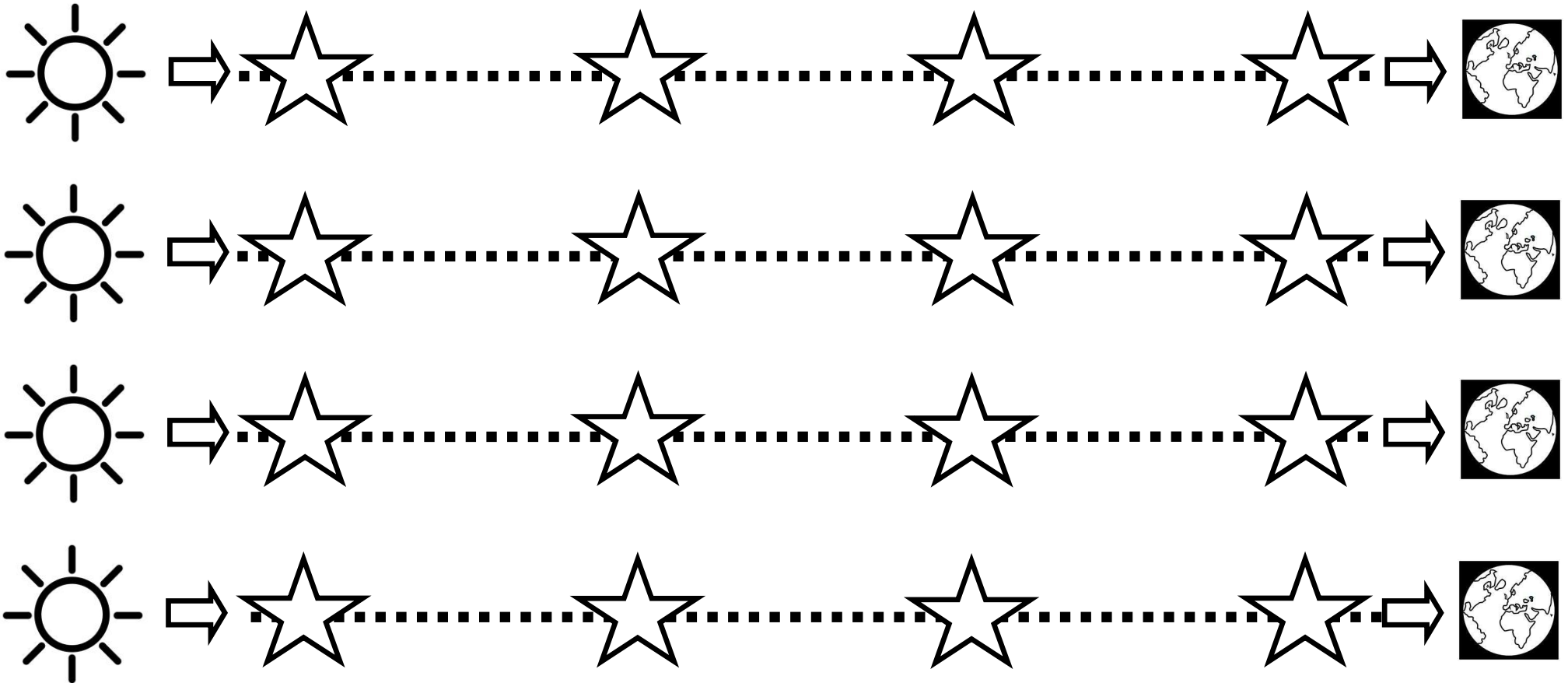



## Actividades para mejorar motricidad fina

Sigue con tu lápiz las estrellitas para ir desde el sol a la tierra



## Actividades para mejorar motricidad fina

Sigue con tu lápiz las estrellitas para ir desde el sol a la tierra

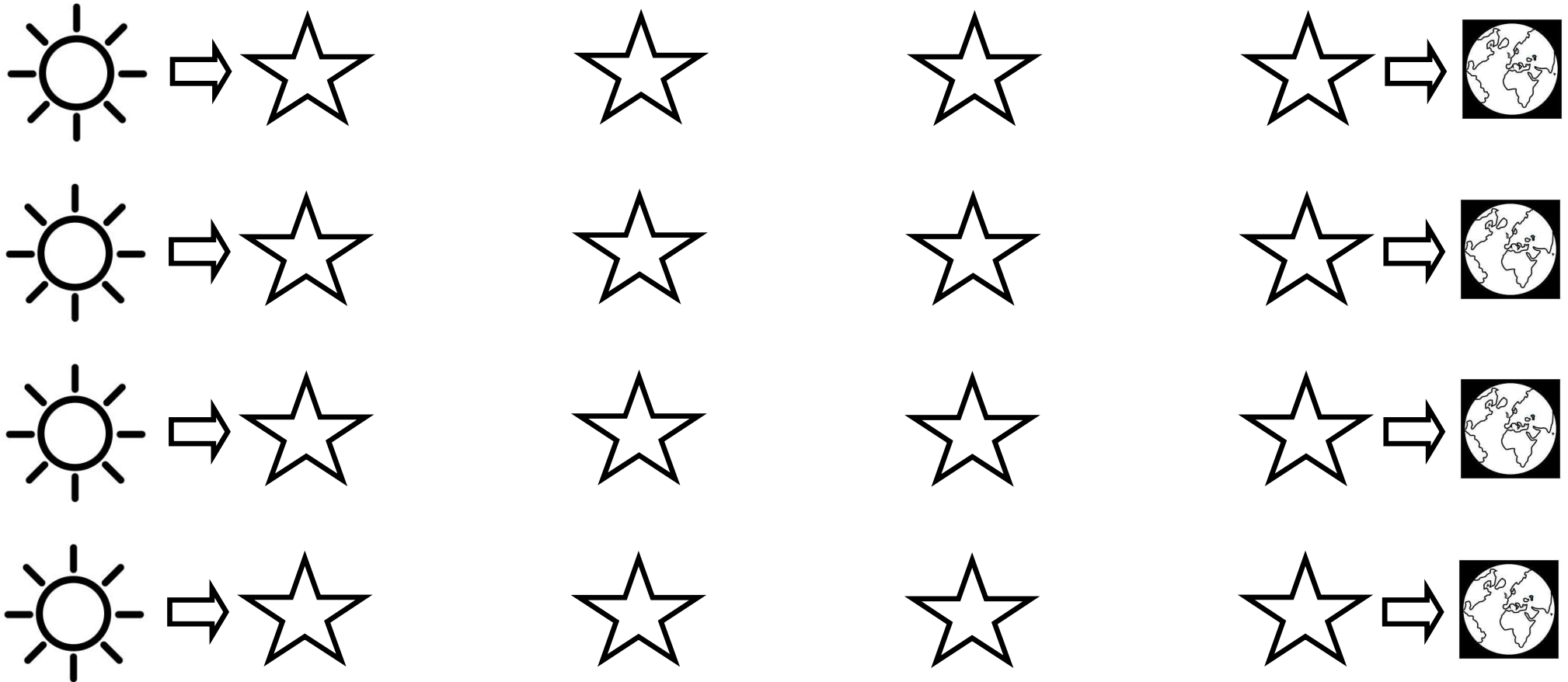

## Actividades para mejorar motricidad fina

Sigue con tu lápiz los corazones para unir a la mama y a su bebe

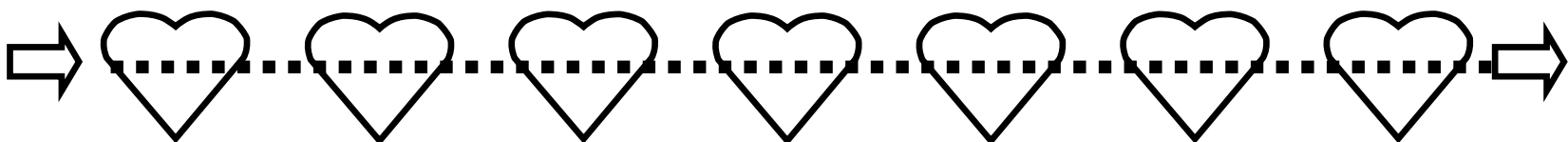
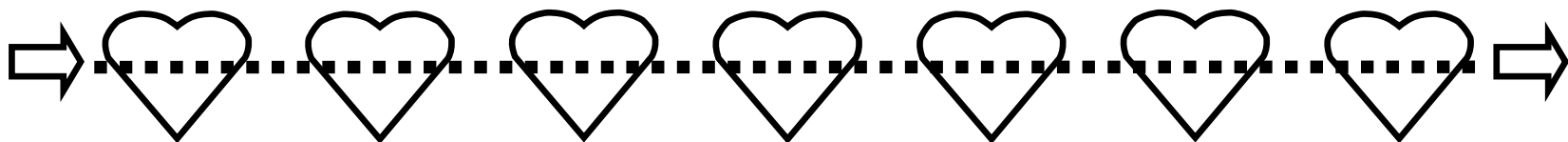
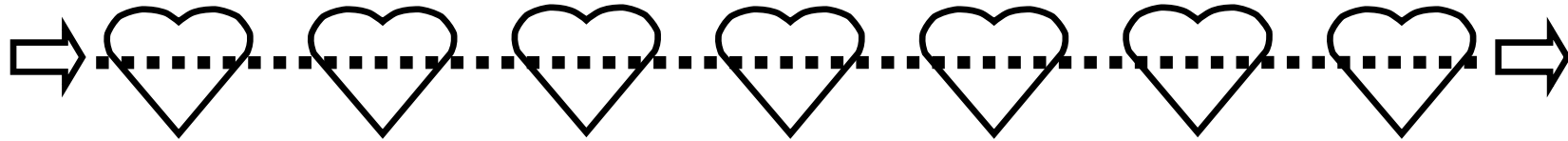

## Actividades para mejorar motricidad fina

Sigue con tu lápiz los corazones para unir a la mama y a su bebe

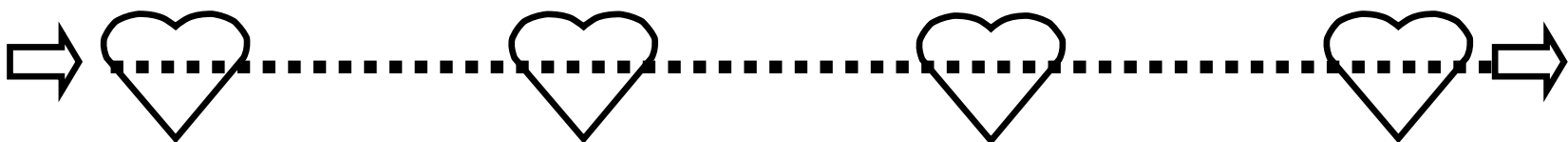
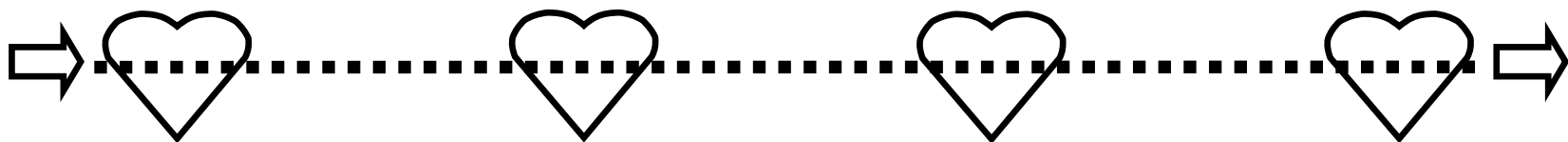
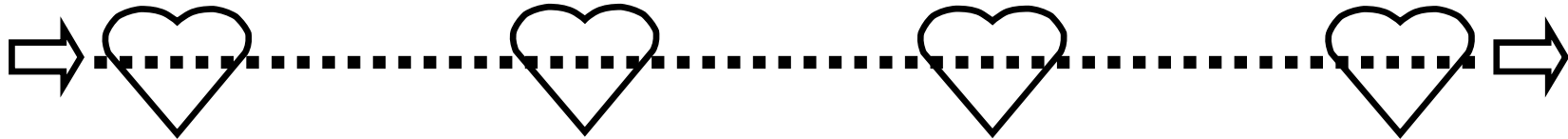
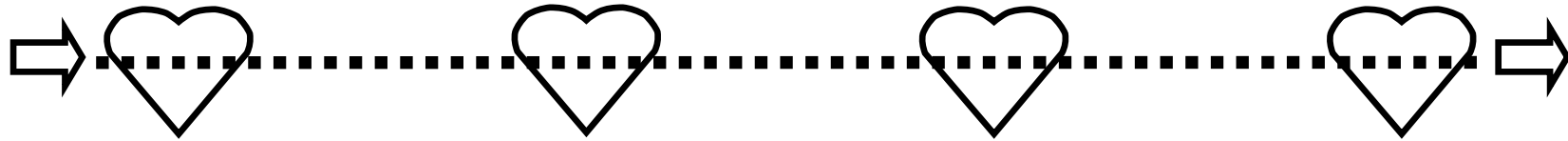

## Actividades para mejorar motricidad fina

Sigue con tu lápiz los corazones para unir a la mama y a su bebe

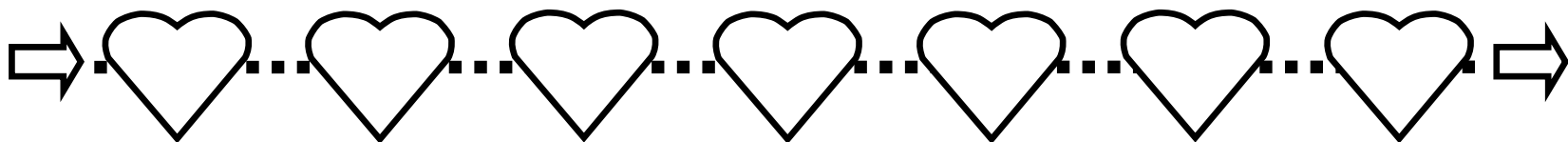
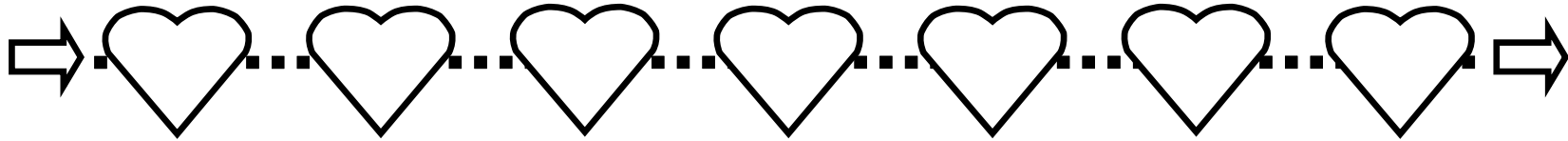

## Actividades para mejorar motricidad fina

Sigue con tu lápiz los corazones para unir a la mama y a su bebe

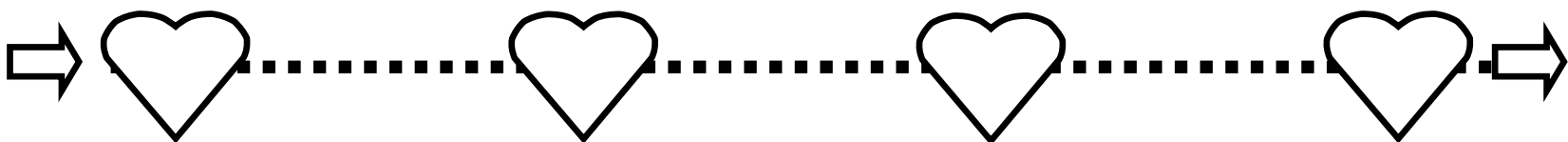
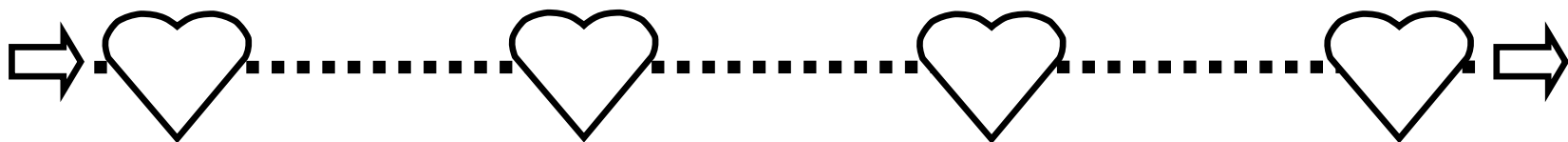
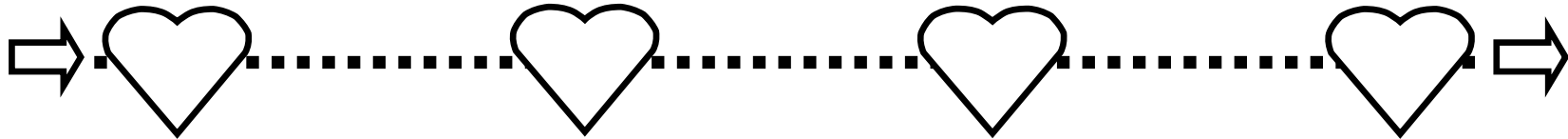
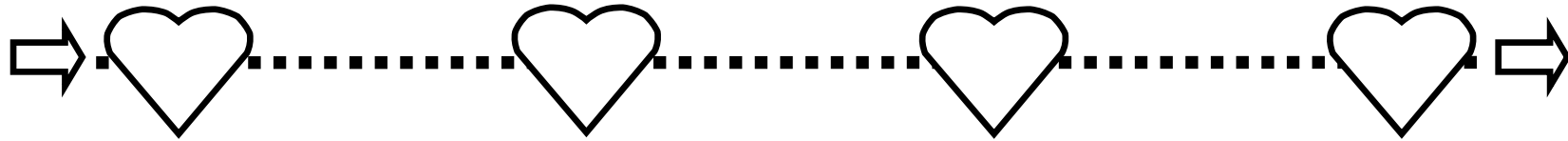

## Actividades para mejorar motricidad fina

Sigue con tu lápiz los corazones para unir a la mama y a su bebe

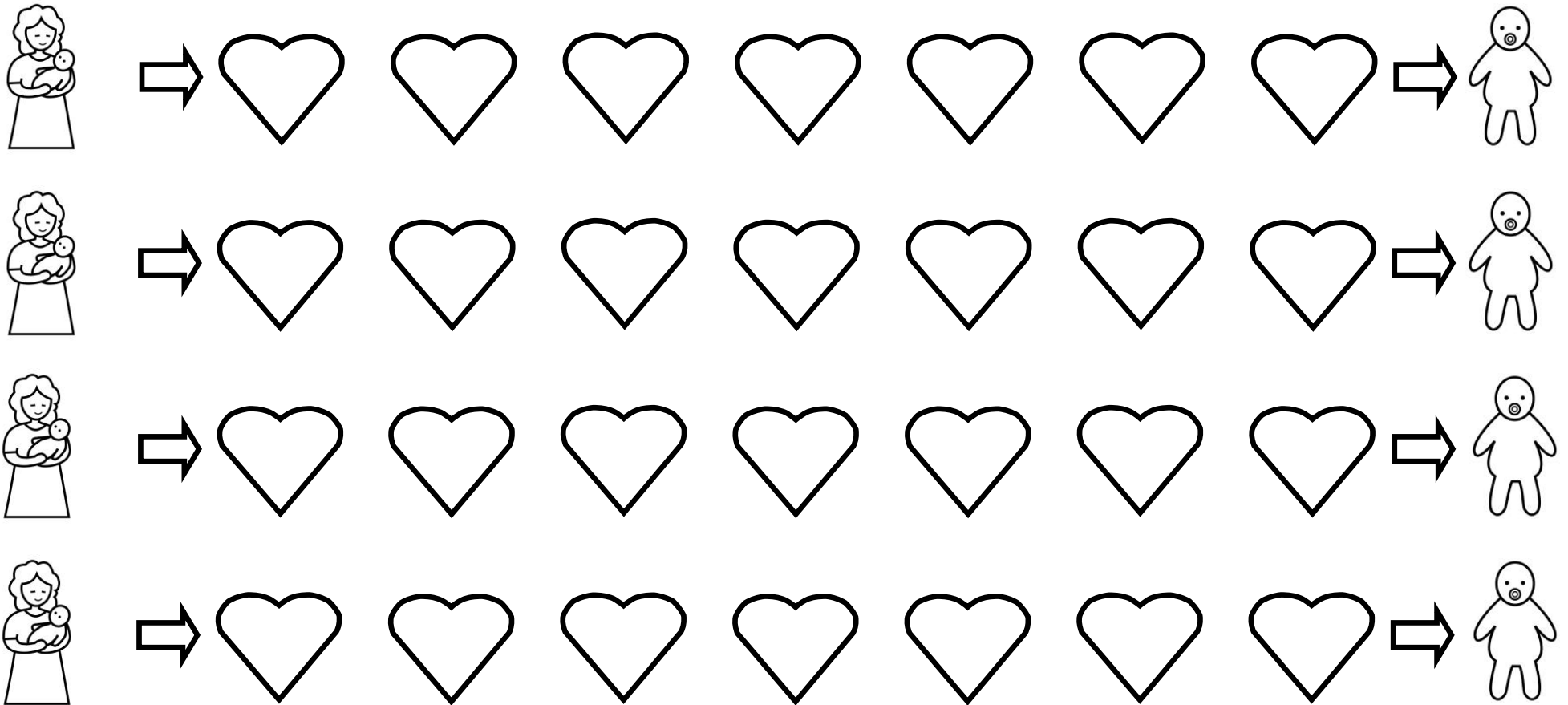

## Actividades para mejorar motricidad fina

Sigue con tu lápiz los corazones para unir a la mama y a su bebe

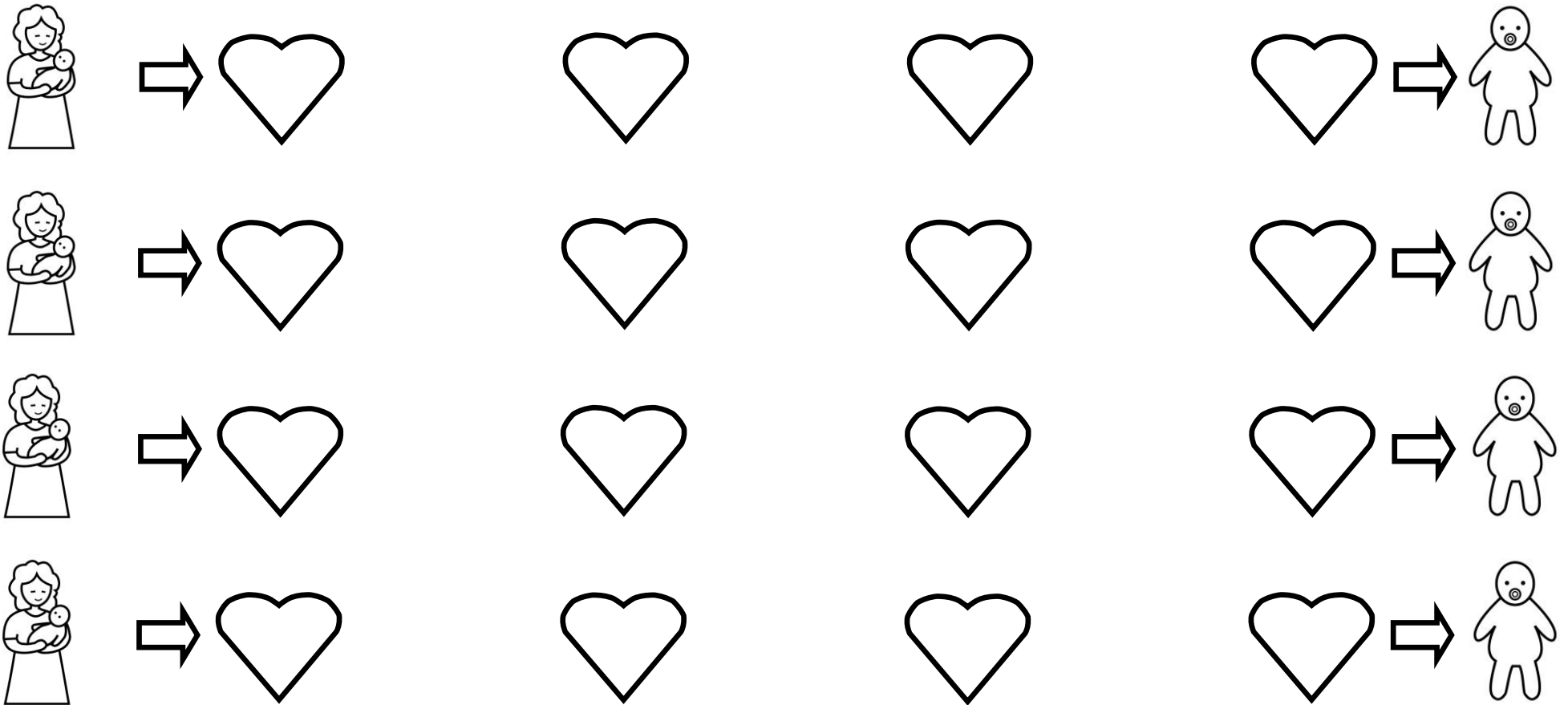



## Actividades para mejorar motricidad fina

Sigue con tu lápiz las caras para unir al niño con su amiga

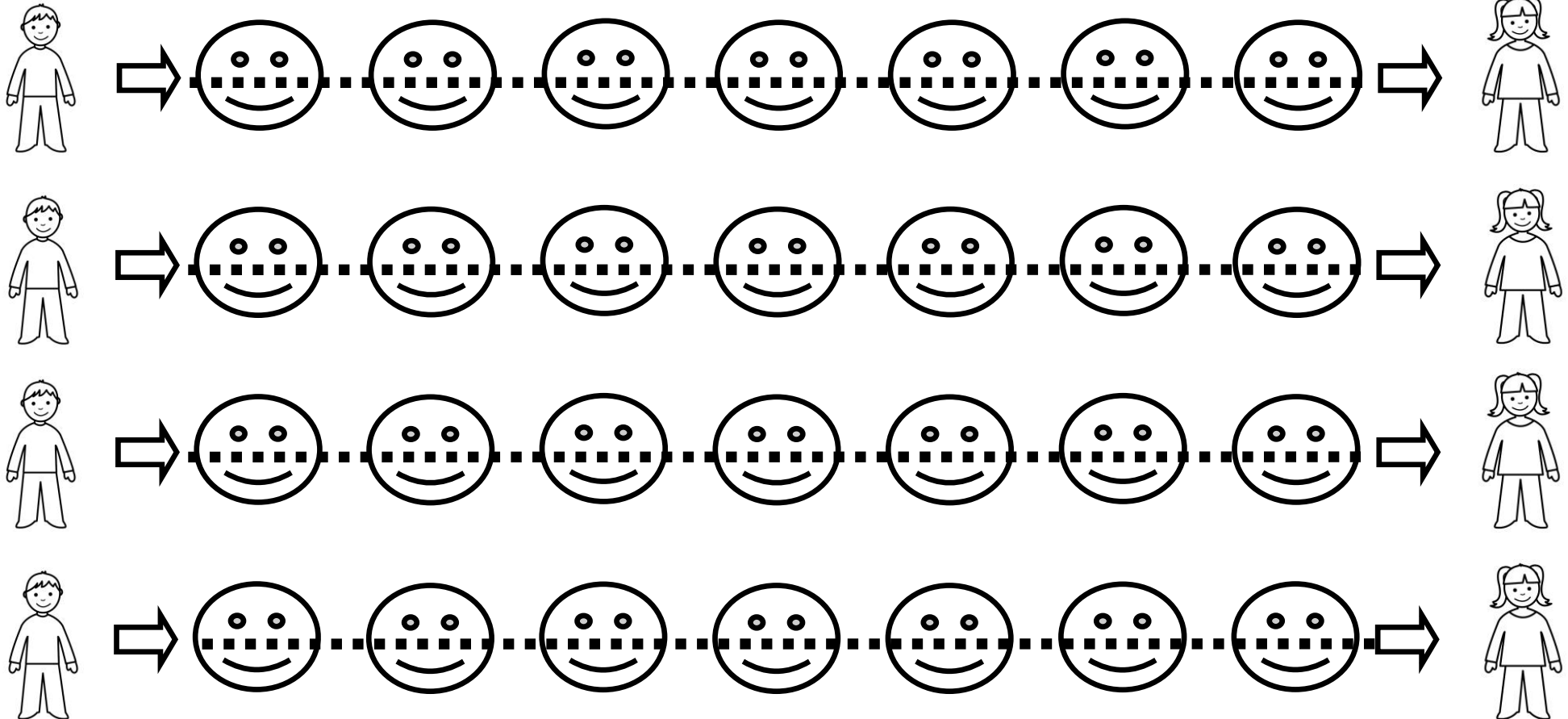

## Actividades para mejorar motricidad fina

Sigue con tu lápiz las caras para unir al niño con su amiga

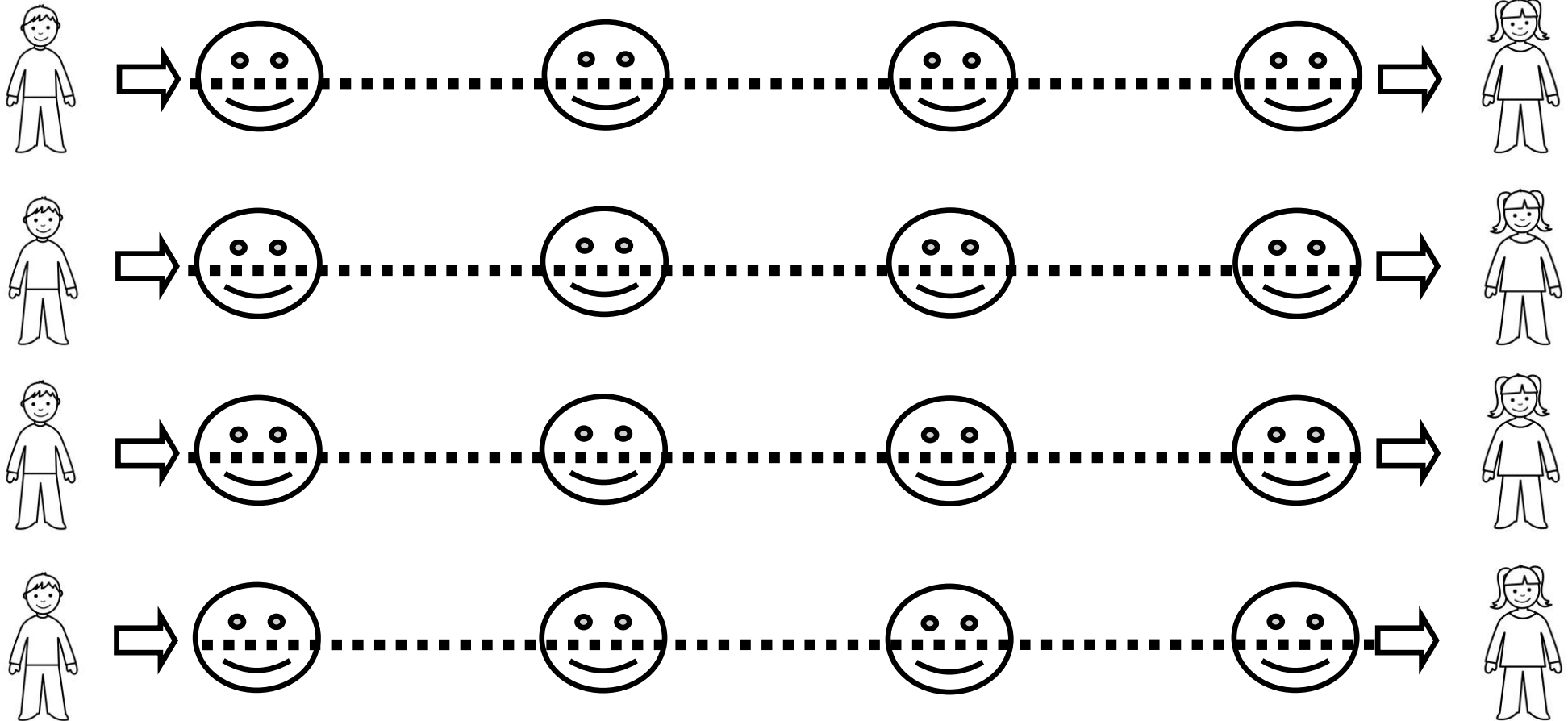

## Actividades para mejorar motricidad fina

Sigue con tu lápiz las caras para unir al niño con su amiga

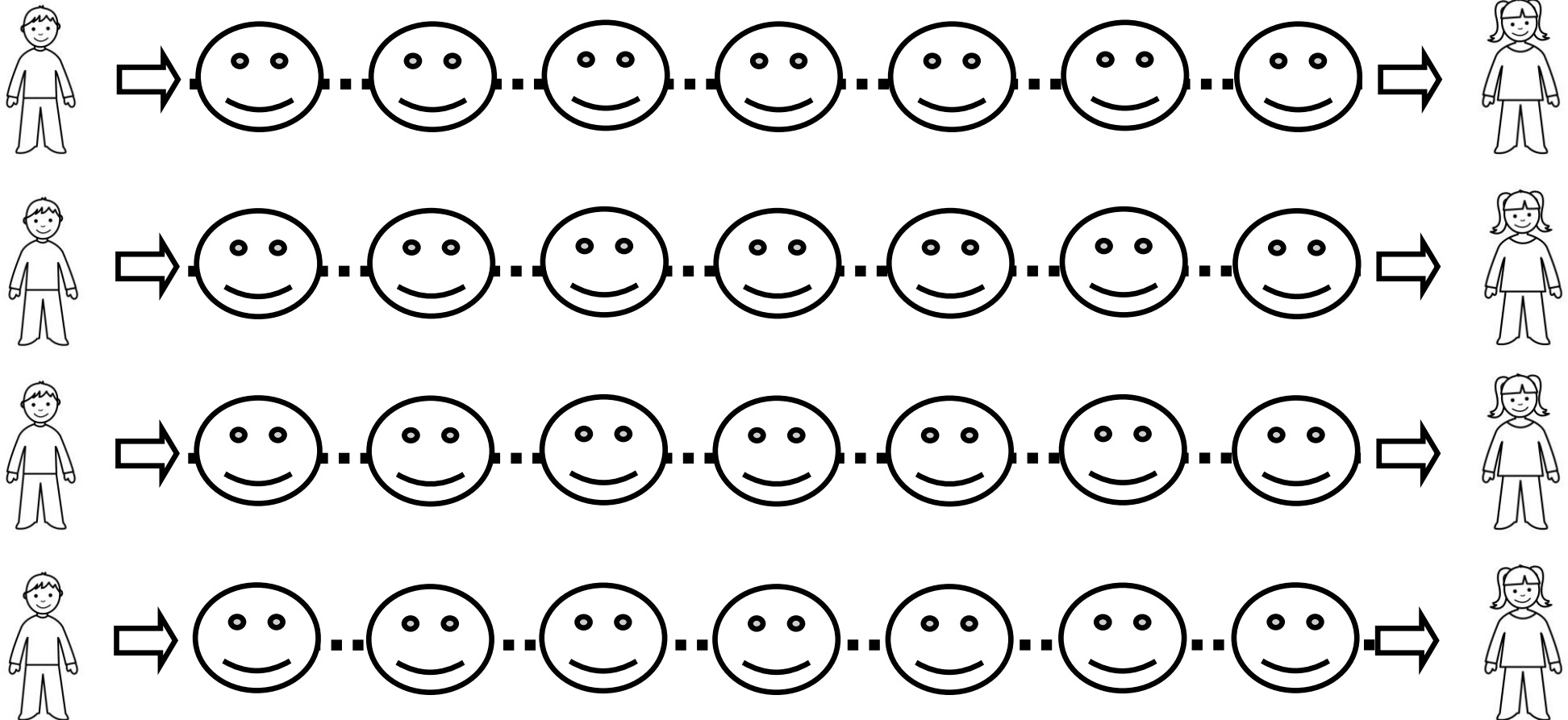

## Actividades para mejorar motricidad fina

Sigue con tu lápiz las caras para unir al niño con su amiga

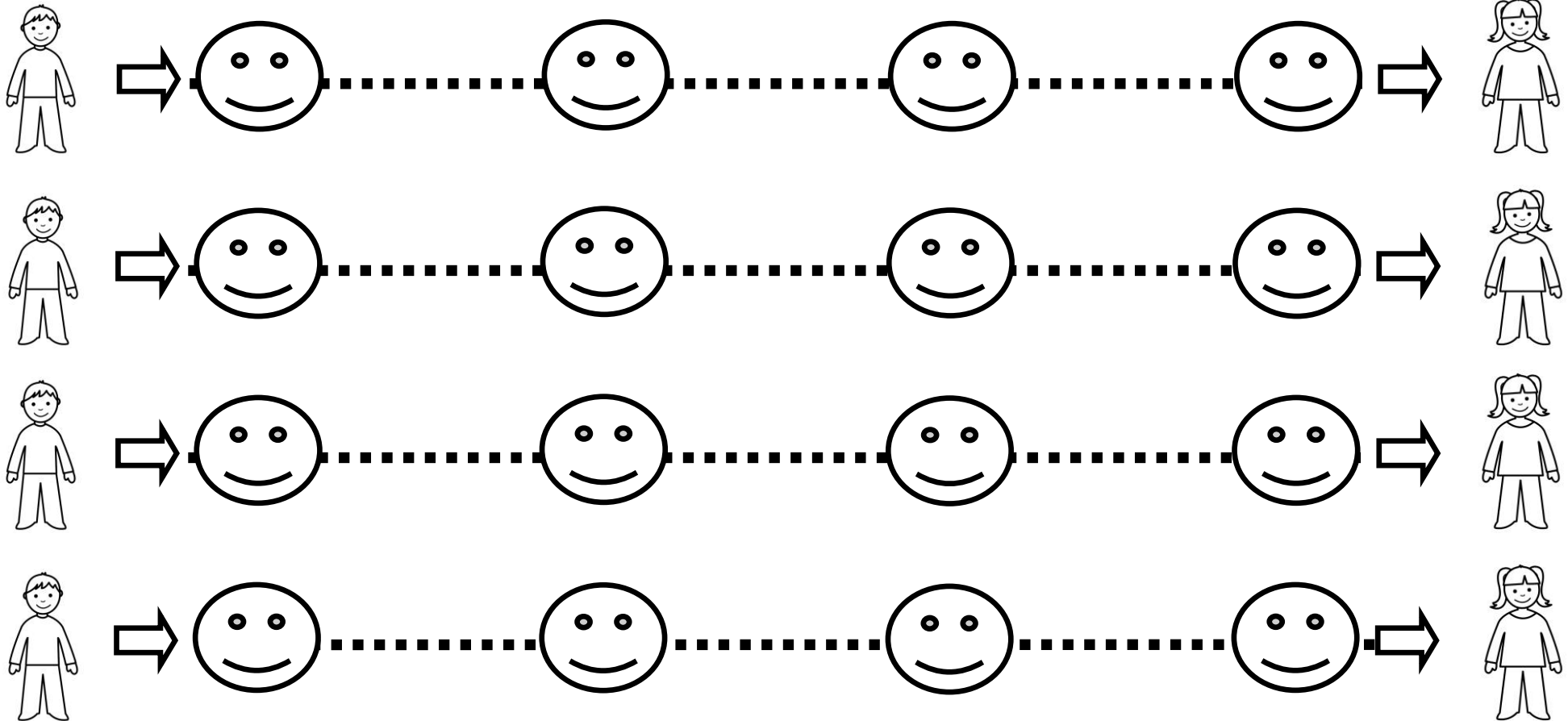

## Actividades para mejorar motricidad fina

Sigue con tu lápiz las caras para unir al niño con su amiga

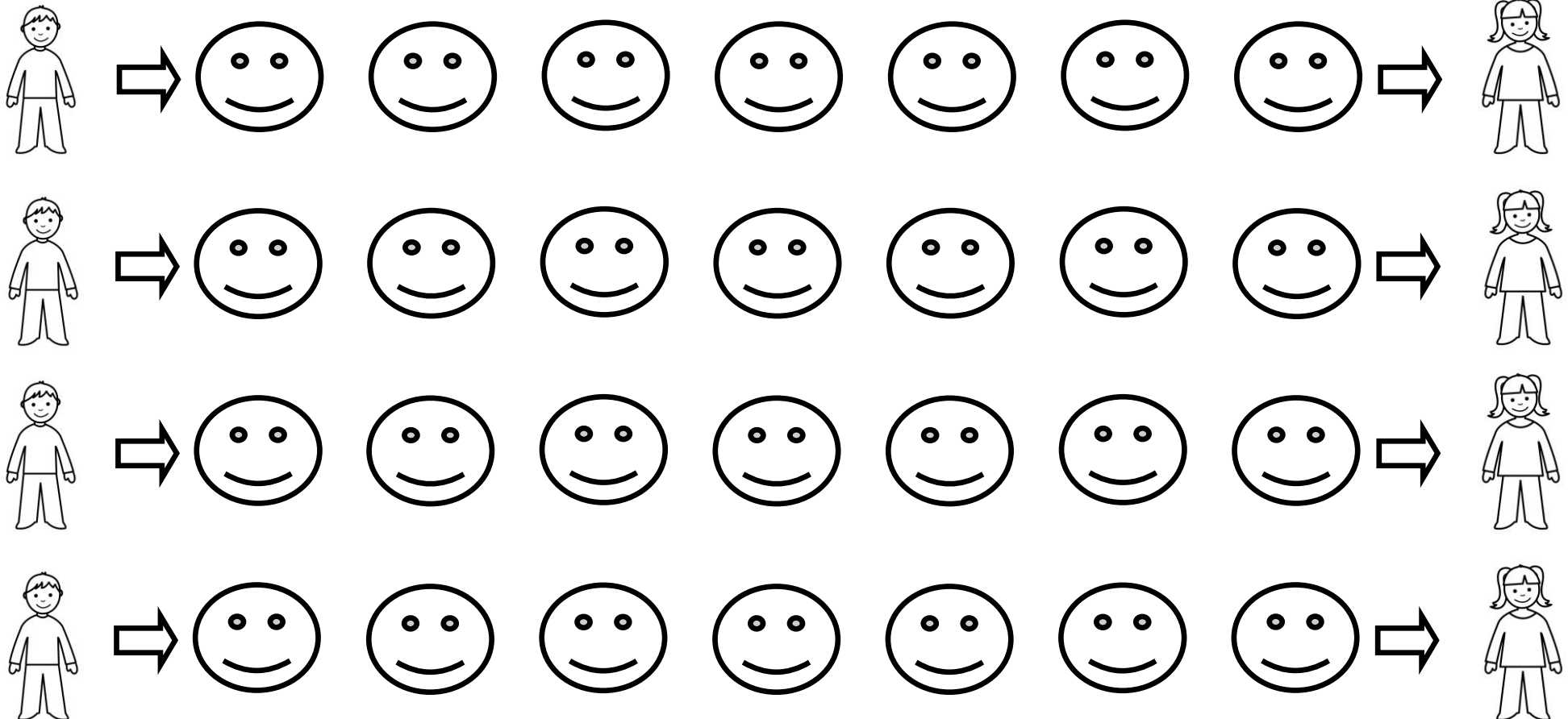

## Actividades para mejorar motricidad fina

Sigue con tu lápiz las caras para unir al niño con su amiga

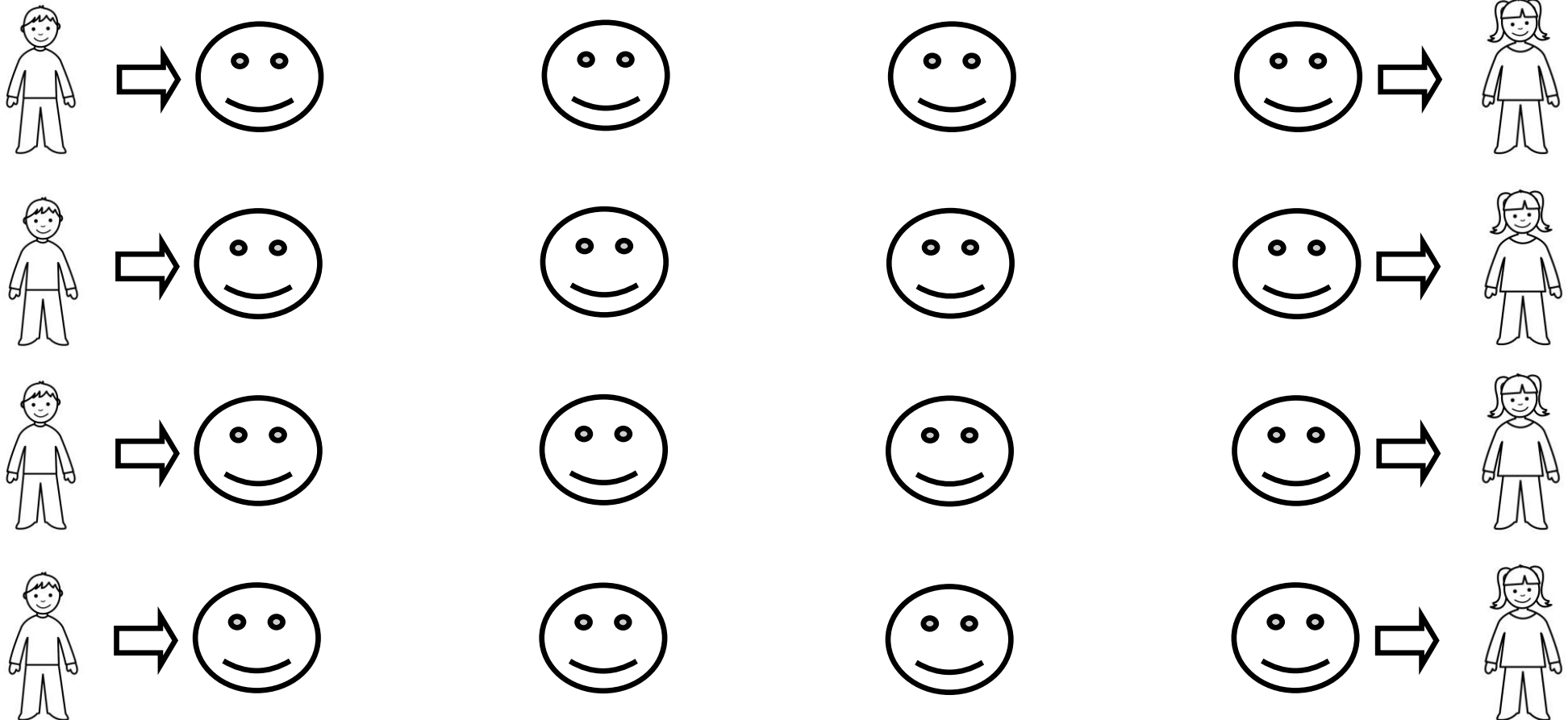

## Actividades para mejorar motricidad fina

Sigue con tu lápiz los círculos para unir al niño con su balón

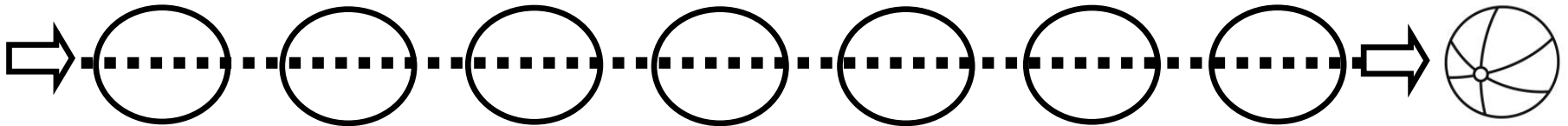
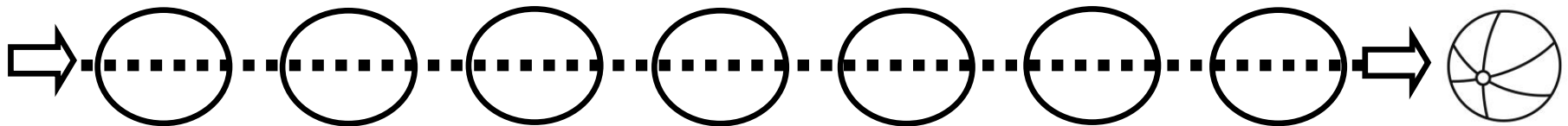
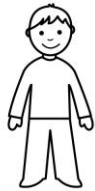
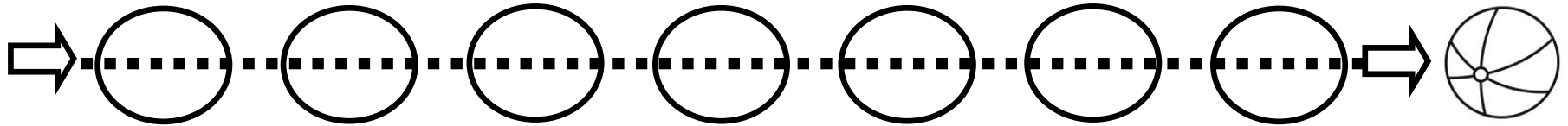
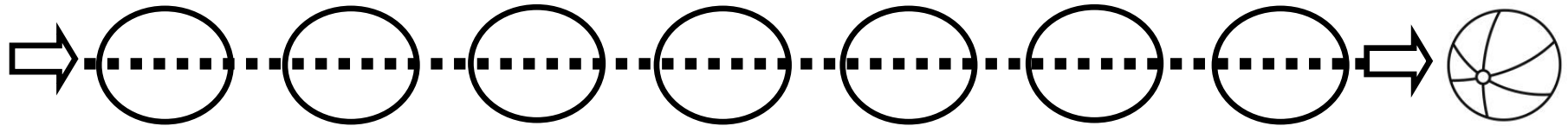
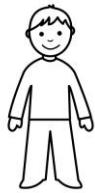

## Actividades para mejorar motricidad fina

Sigue con tu lápiz los círculos para unir al niño con su balón

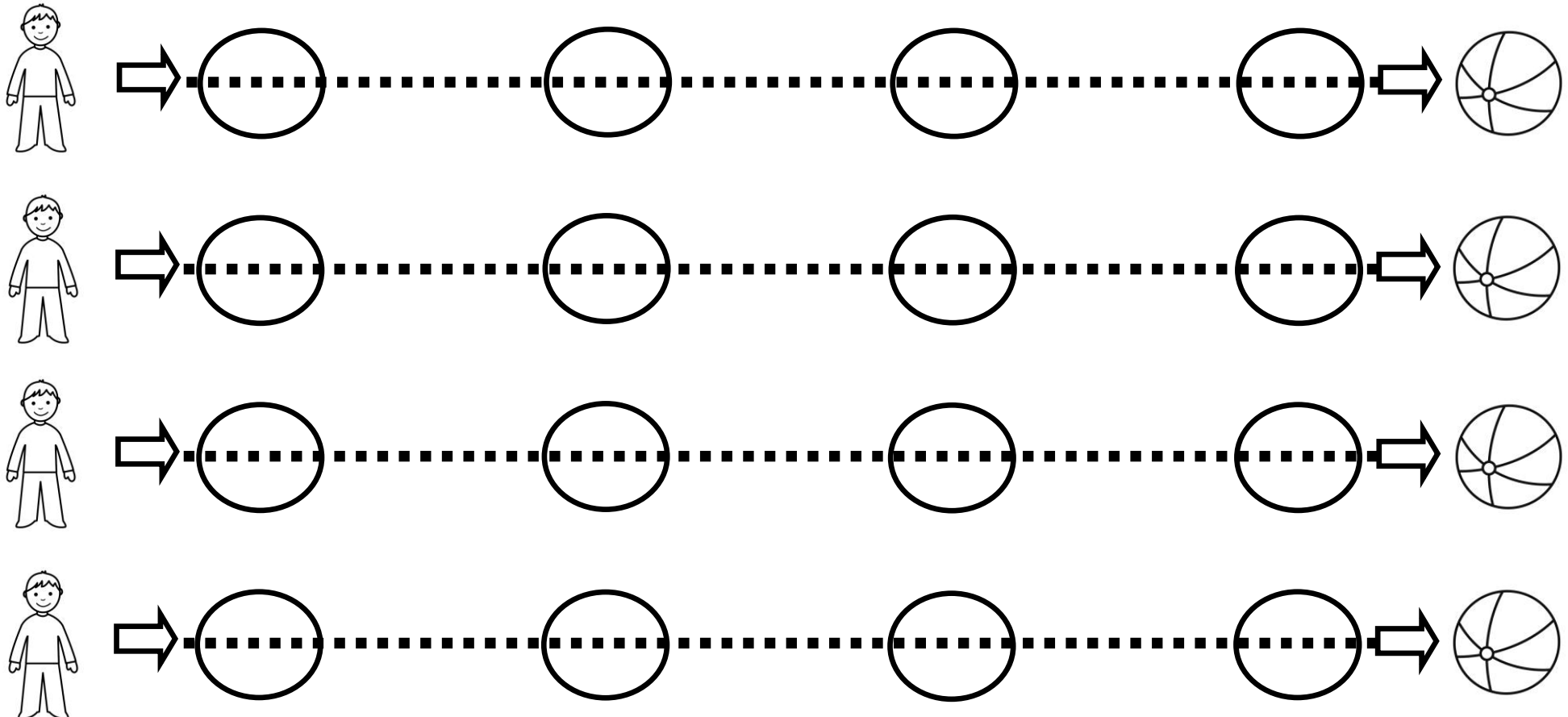



## Actividades para mejorar motricidad fina

Sigue con tu lápiz los círculos para unir al niño con su balón

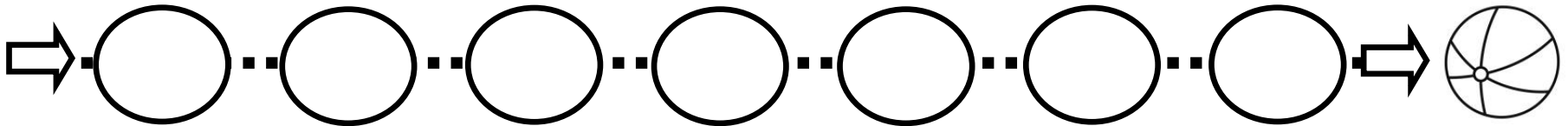
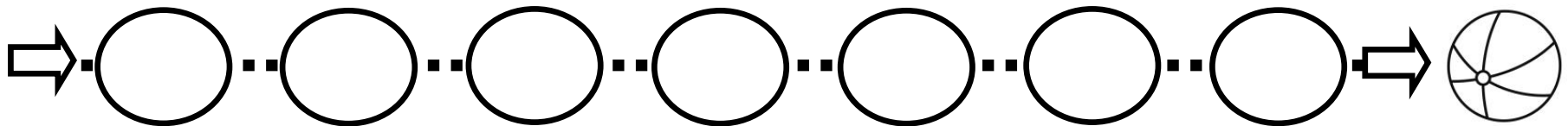
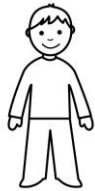
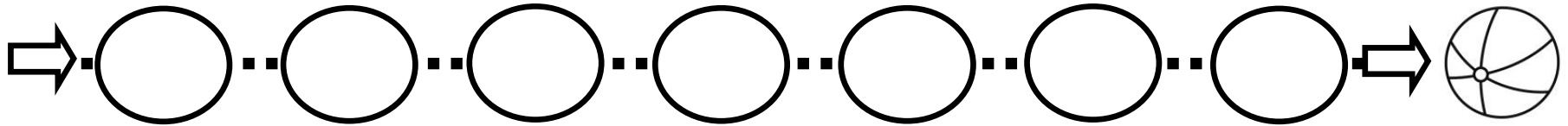
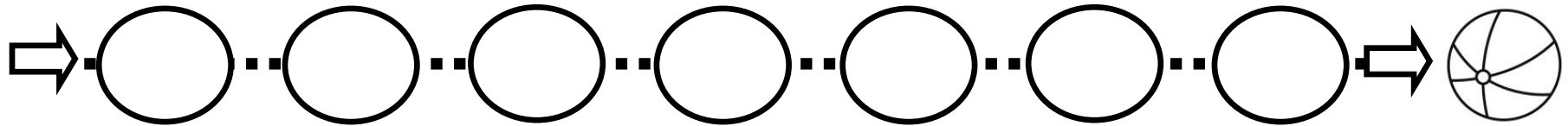
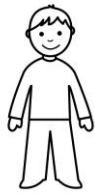

## Actividades para mejorar motricidad fina

Sigue con tu lápiz los círculos para unir al niño con su balón

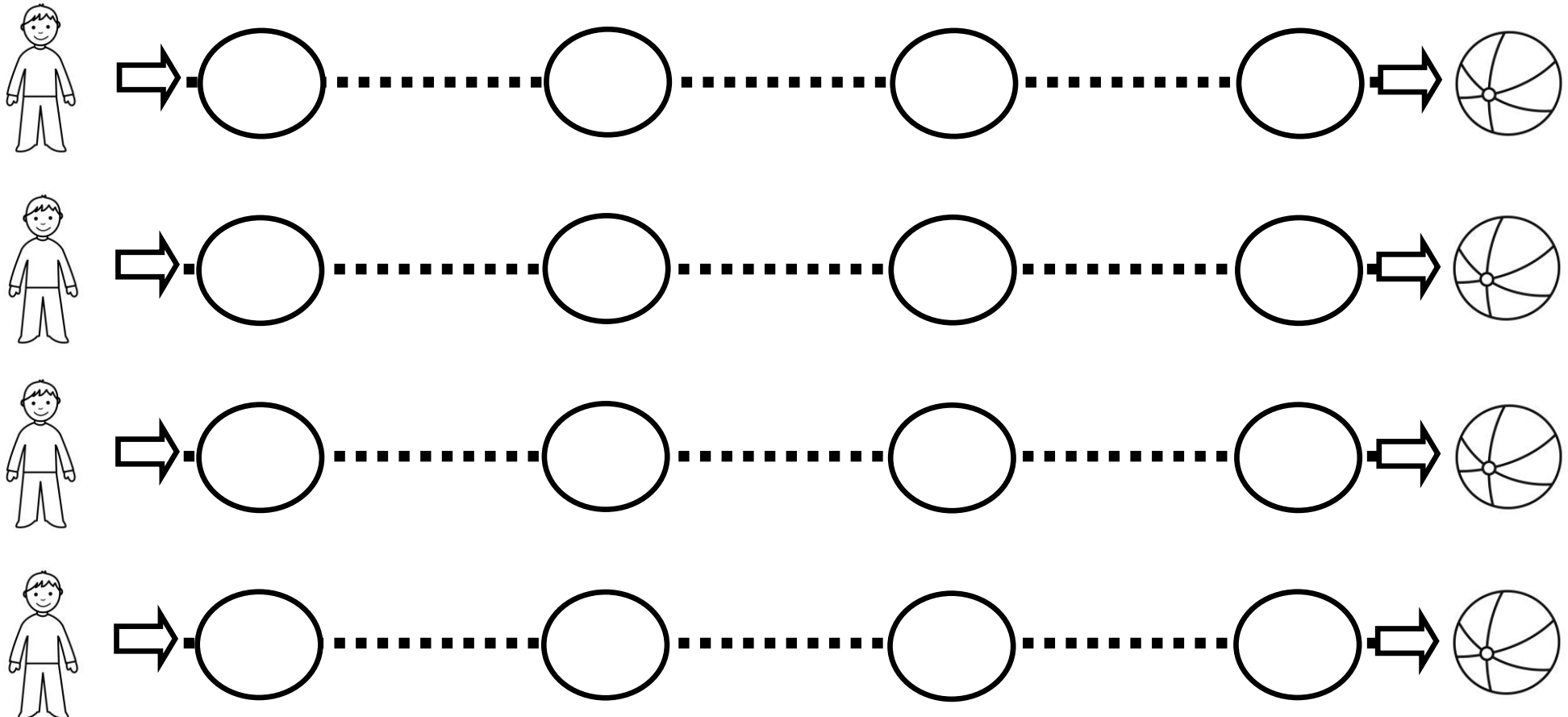

## Actividades para mejorar motricidad fina

Sigue con tu lápiz los círculos para unir al niño con su balón

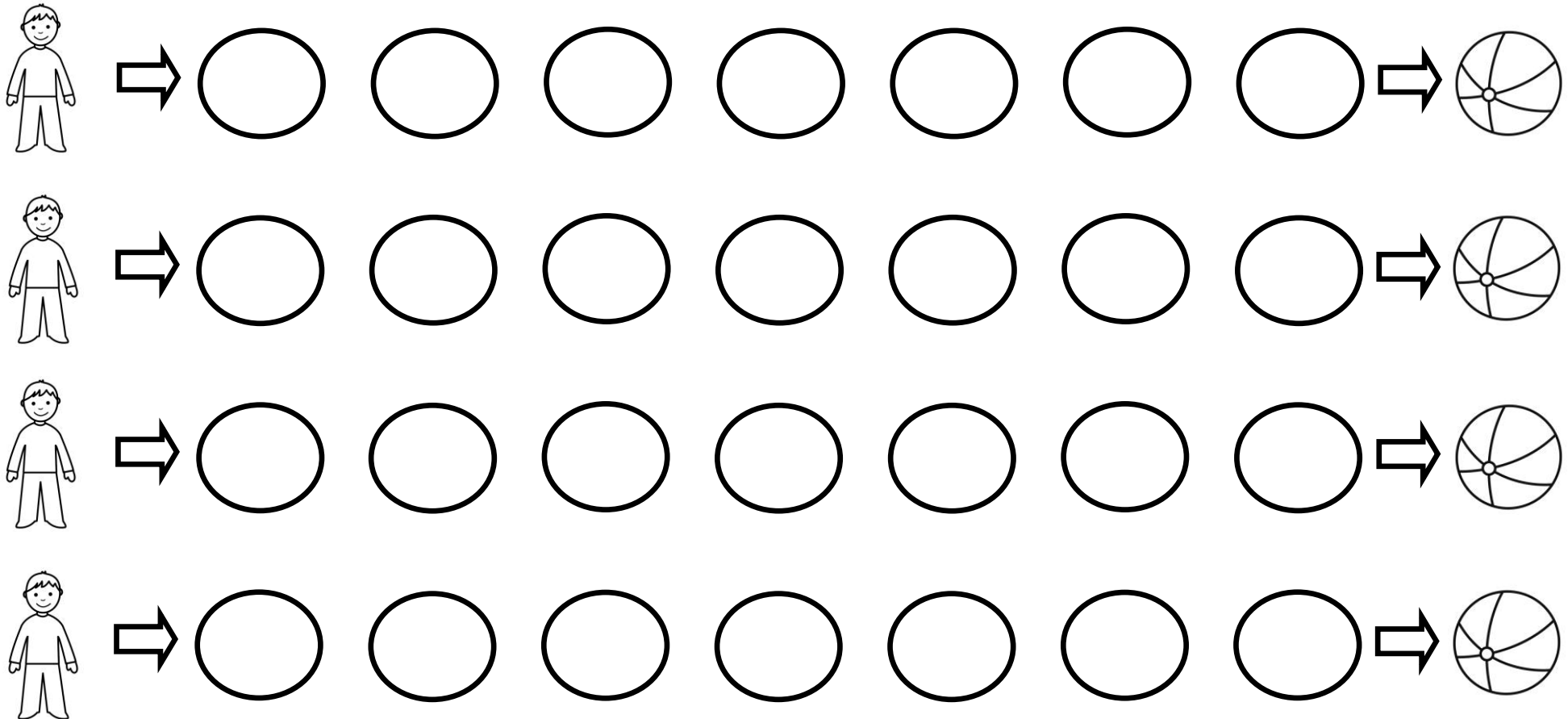

## Actividades para mejorar motricidad fina

Sigue con tu lápiz los círculos para unir al niño con su balón

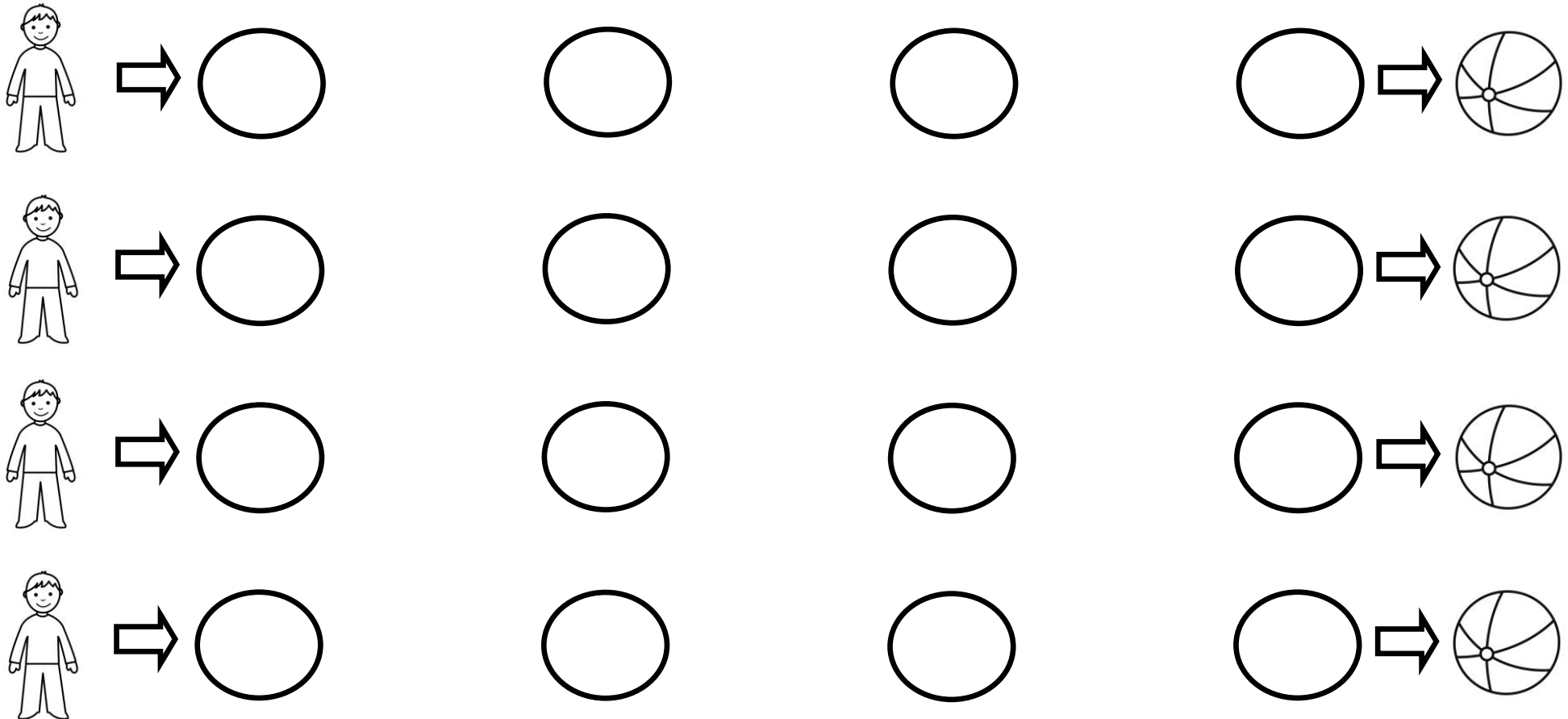

## Actividades para mejorar motricidad fina

Sigue con tu lápiz los rayos para unir a nube y la tierra

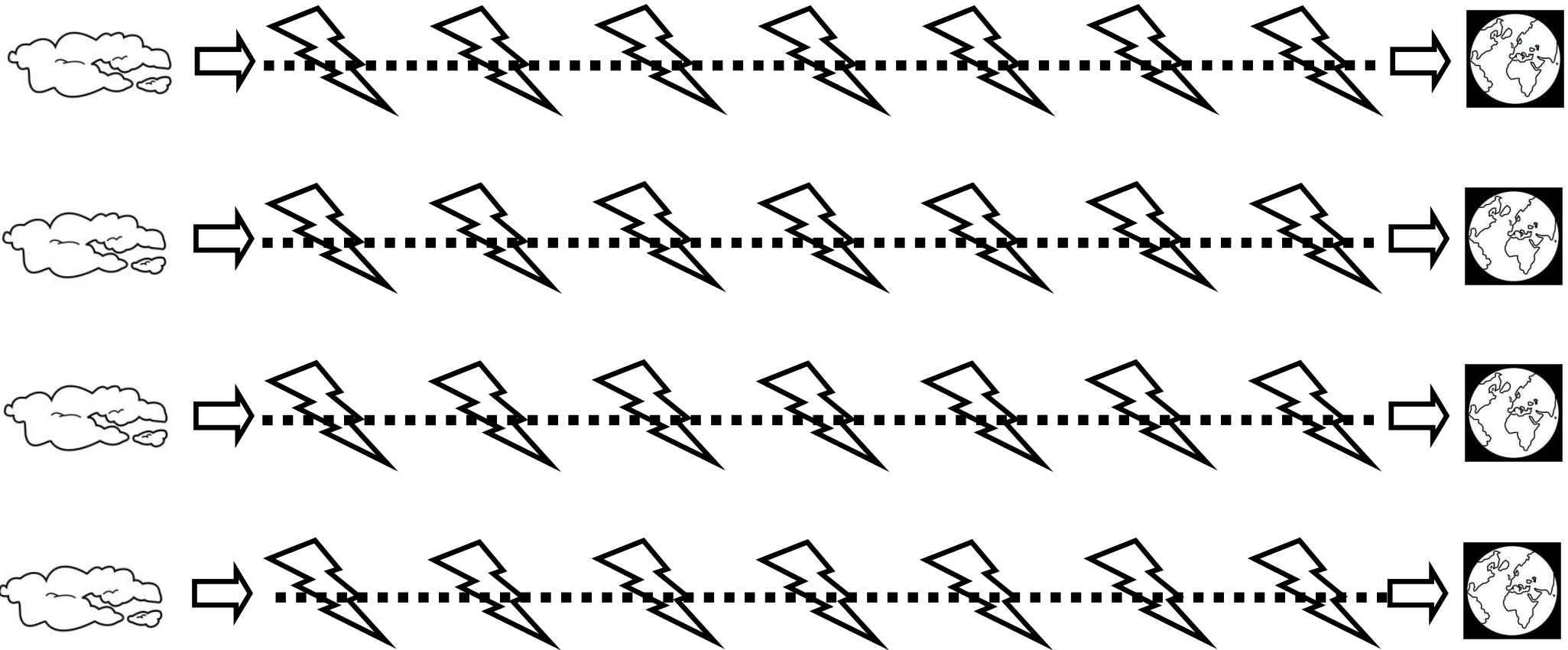

## Actividades para mejorar motricidad fina

Sigue con tu lápiz los rayos para unir a nube y la tierra

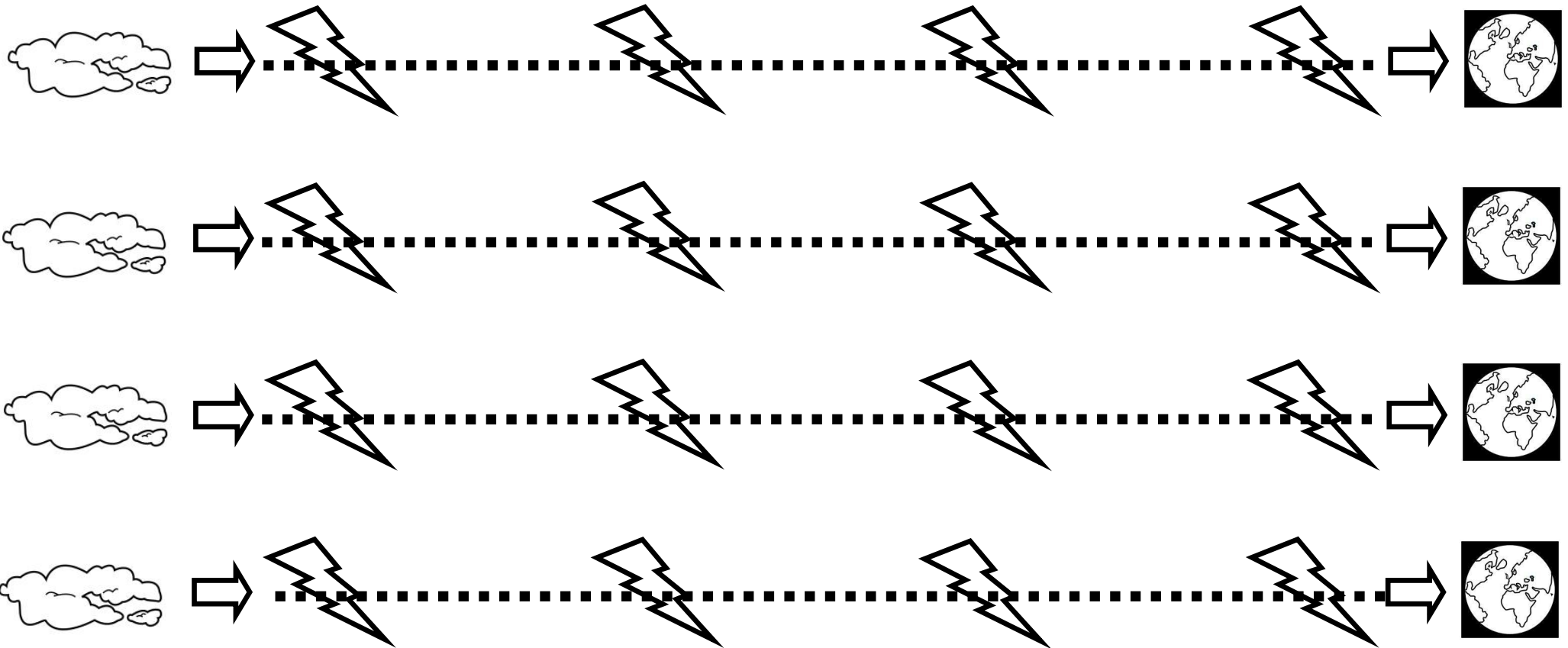

## Actividades para mejorar motricidad fina

Sigue con tu lápiz los rayos para unir a nube y la tierra

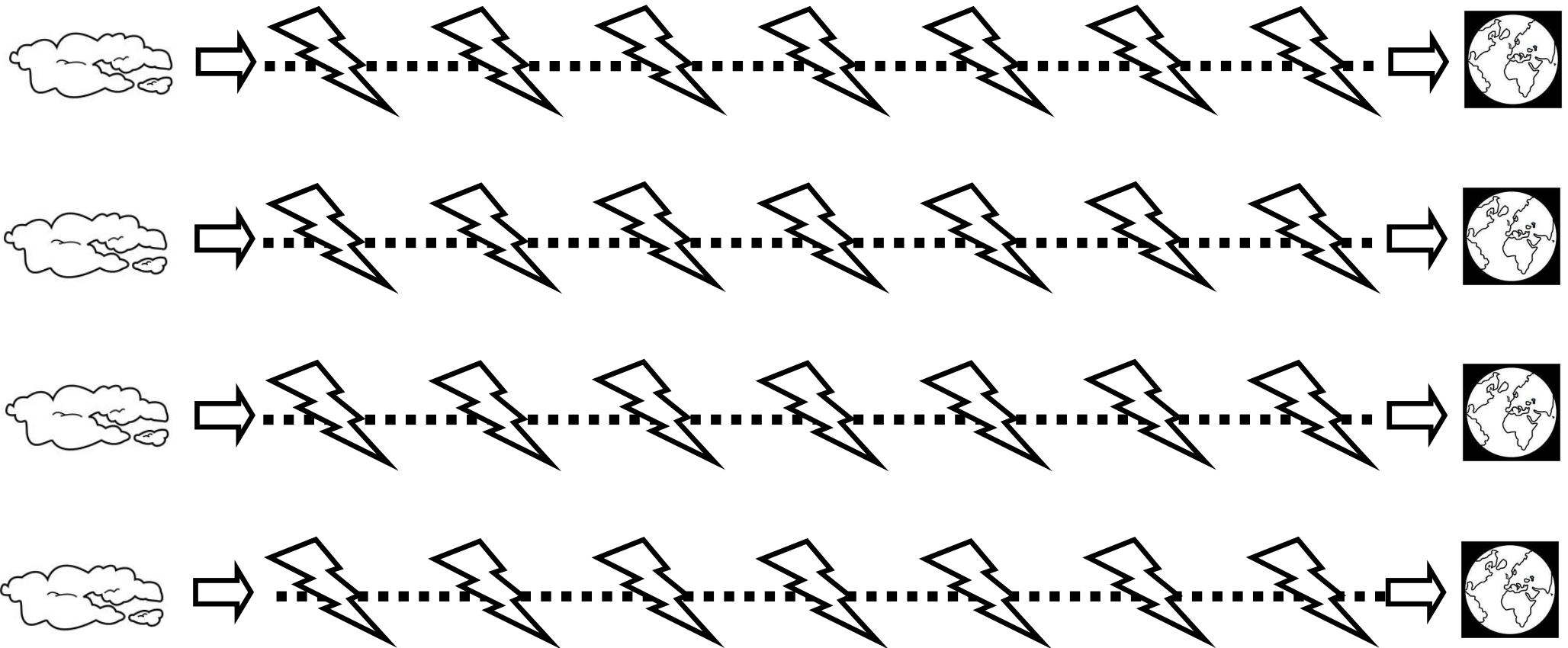

## Actividades para mejorar motricidad fina

Sigue con tu lápiz los rayos para unir a nube y la tierra

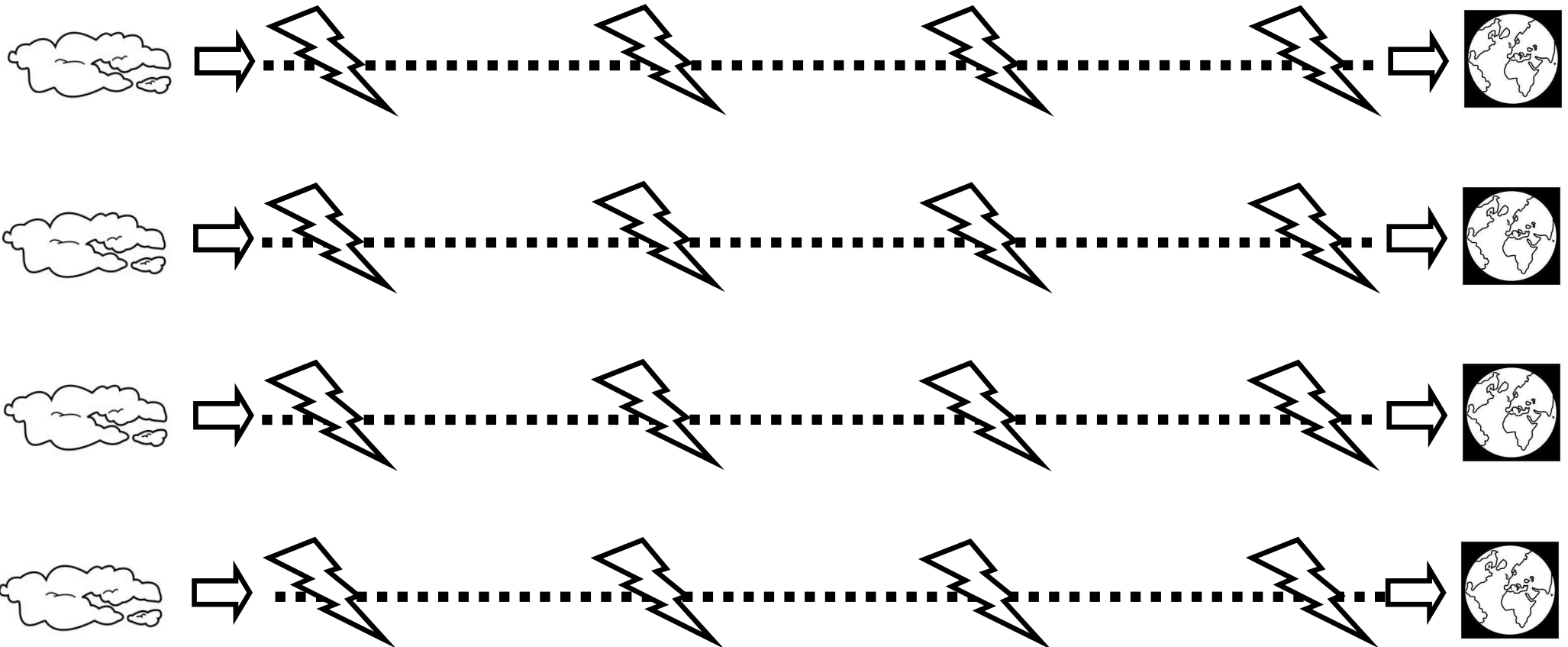



## Actividades para mejorar motricidad fina

Sigue con tu lápiz los rayos para unir a nube y la tierra

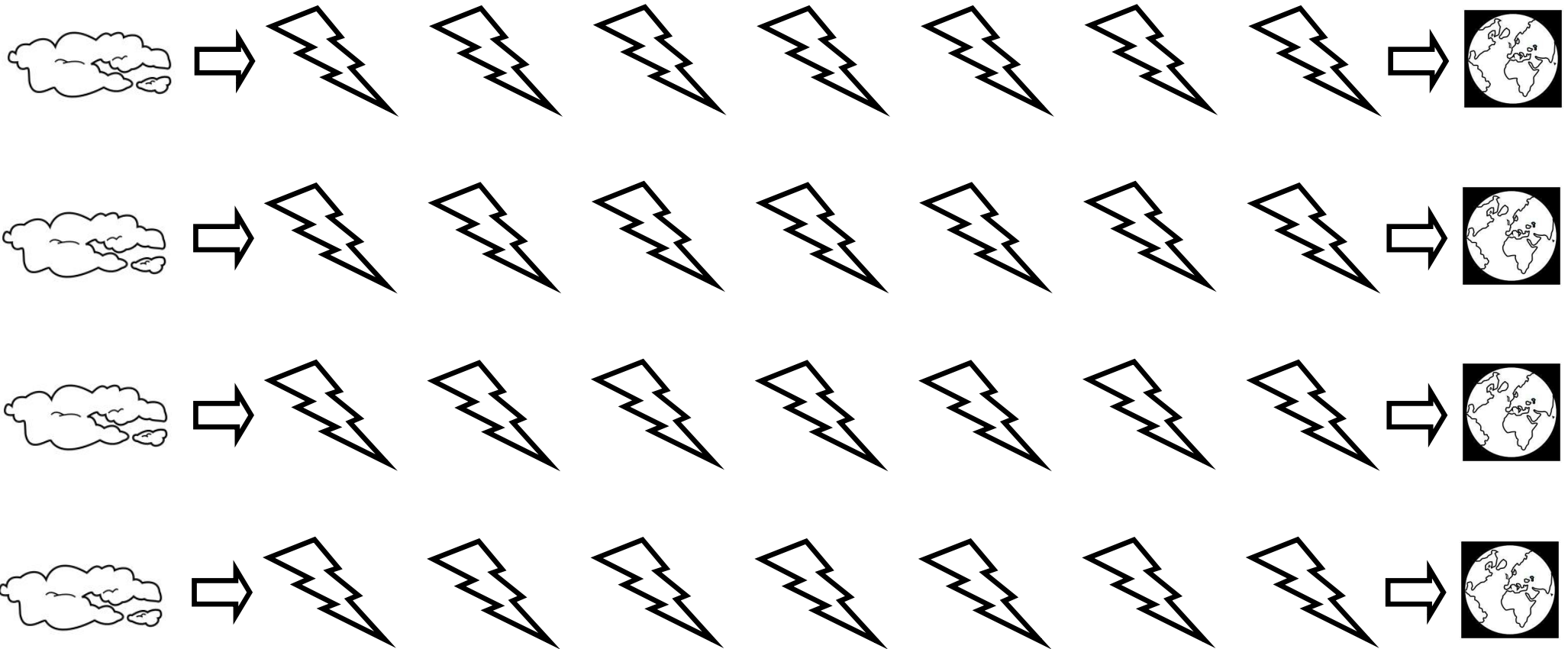

## Actividades para mejorar motricidad fina

Sigue con tu lápiz los rayos para unir a nube y la tierra

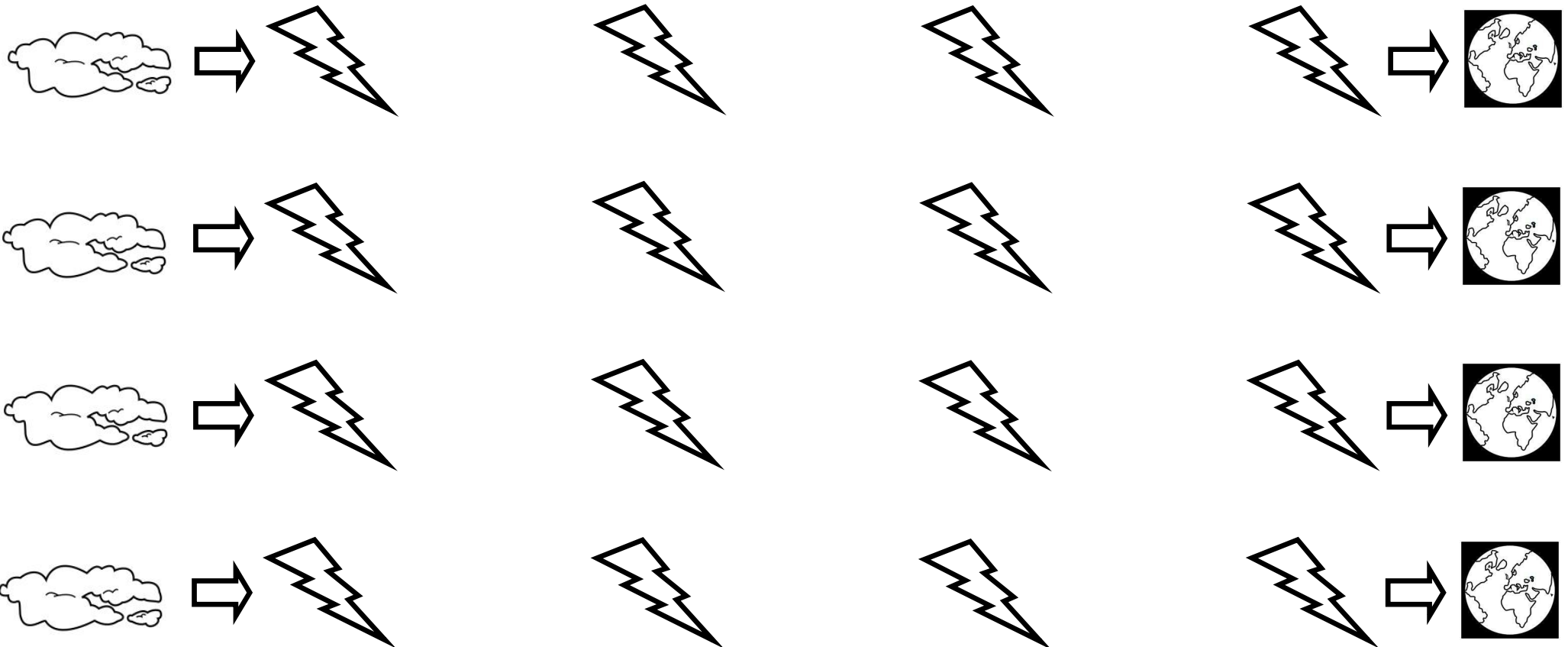

# Actividades para mejorar motricidad fina

Sigue con tu lápiz las estrellitas para ir desde el sol a la tierra

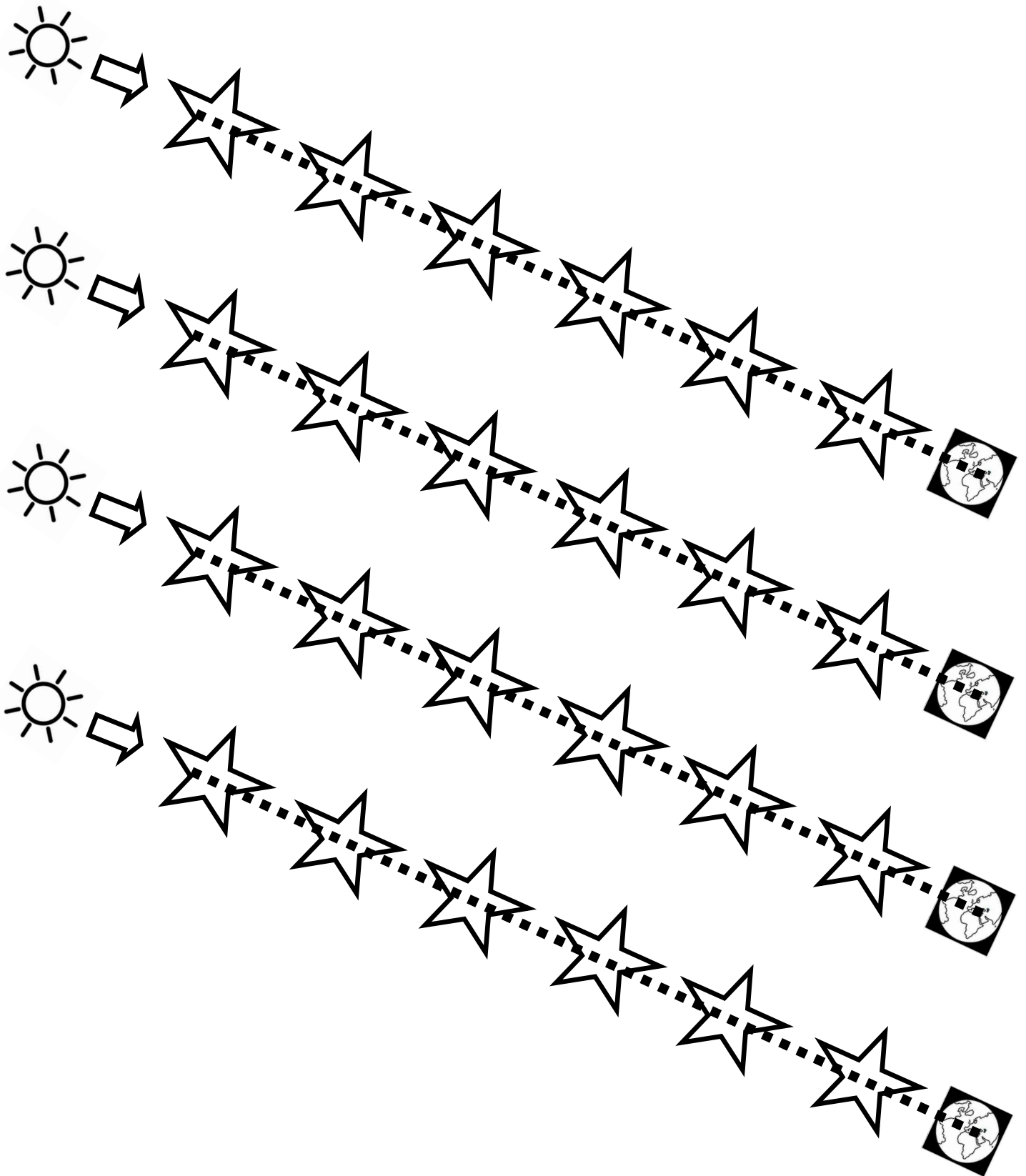

# Actividades para mejorar motricidad fina

Sigue con tu lápiz las estrellitas para ir desde el sol a la tierra

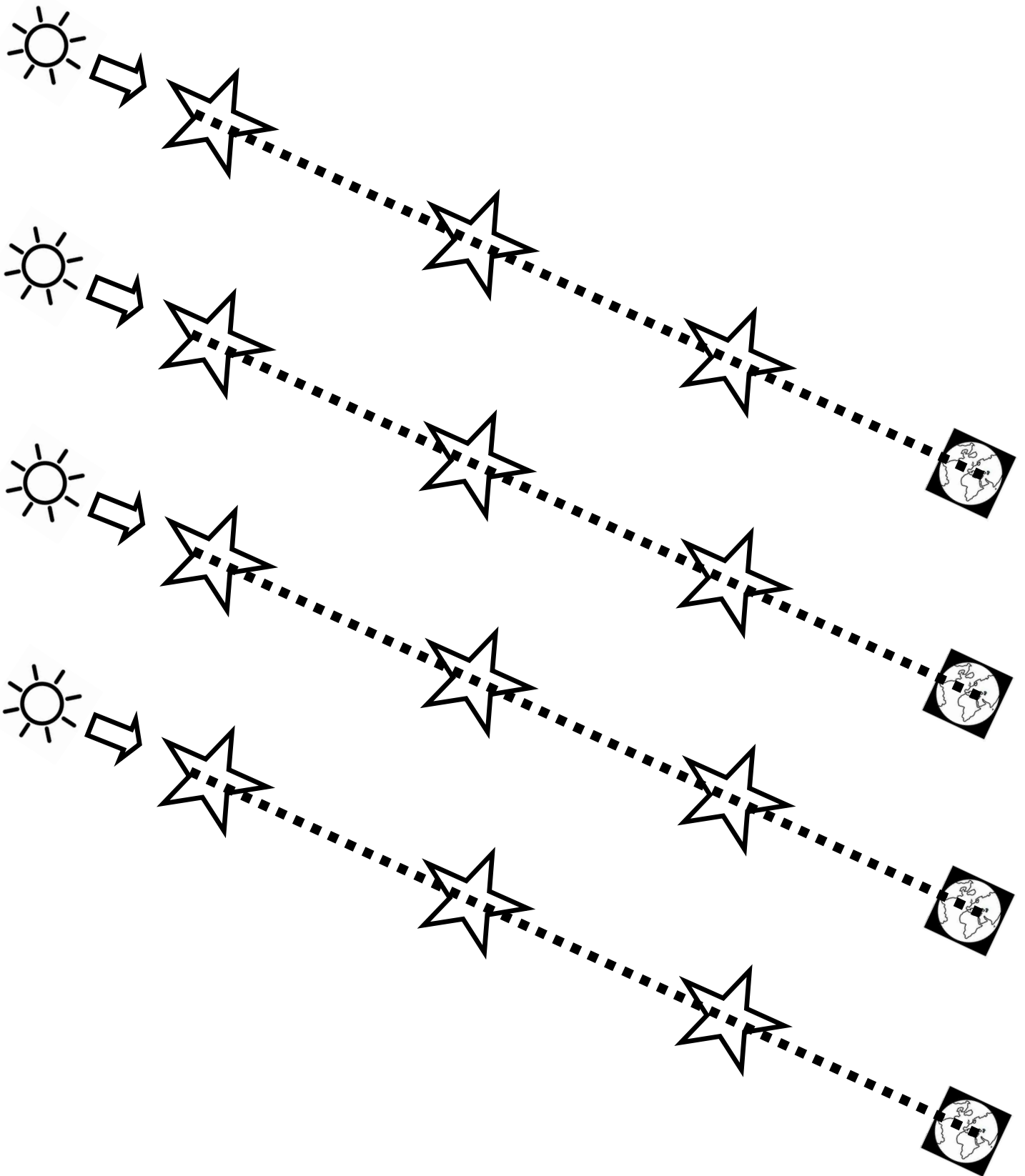

# Actividades para mejorar motricidad fina

Sigue con tu lápiz las estrellitas para ir desde el sol a la tierra

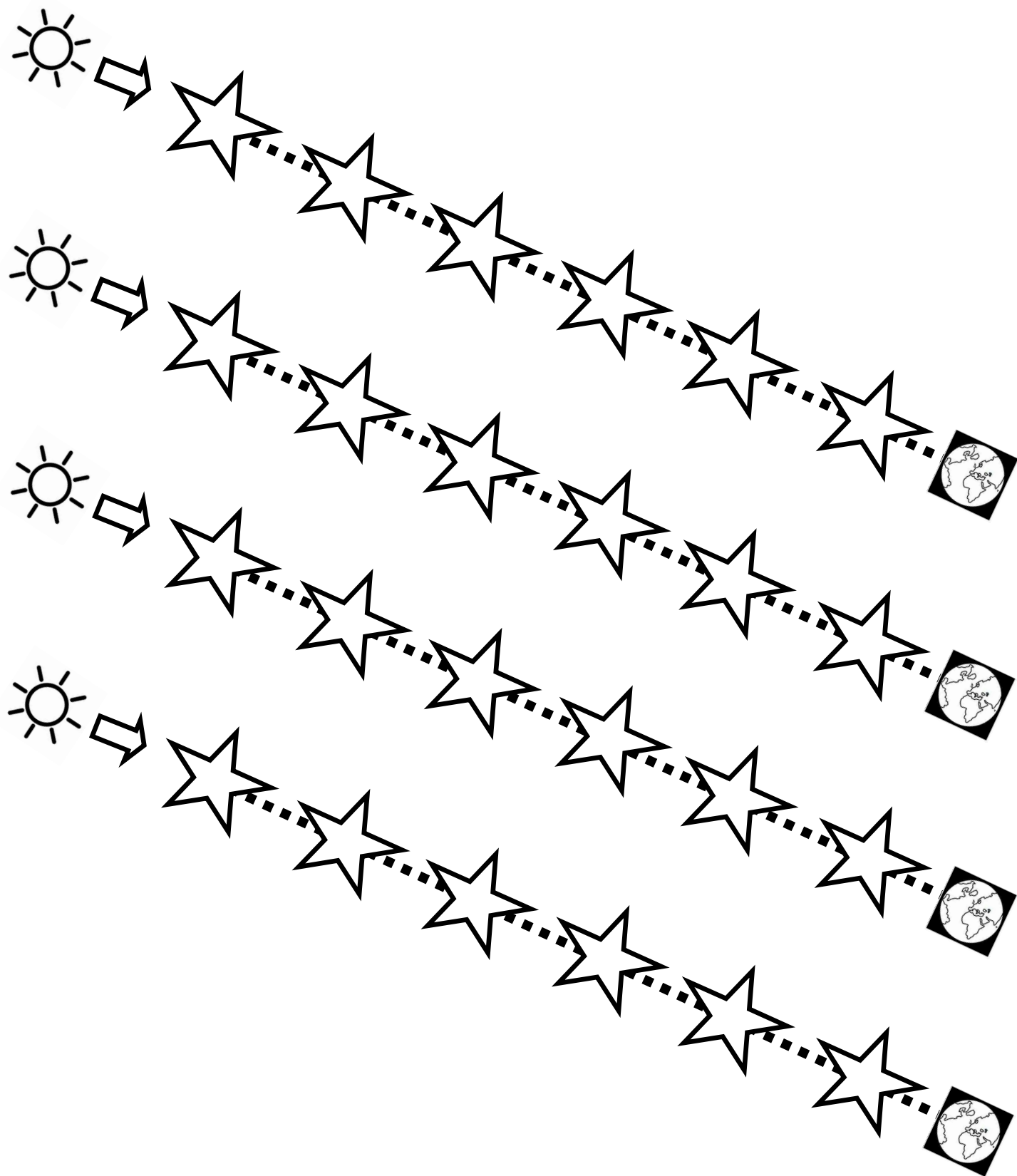

# Actividades para mejorar motricidad fina

Sigue con tu lápiz las estrellitas para ir desde el sol a la tierra

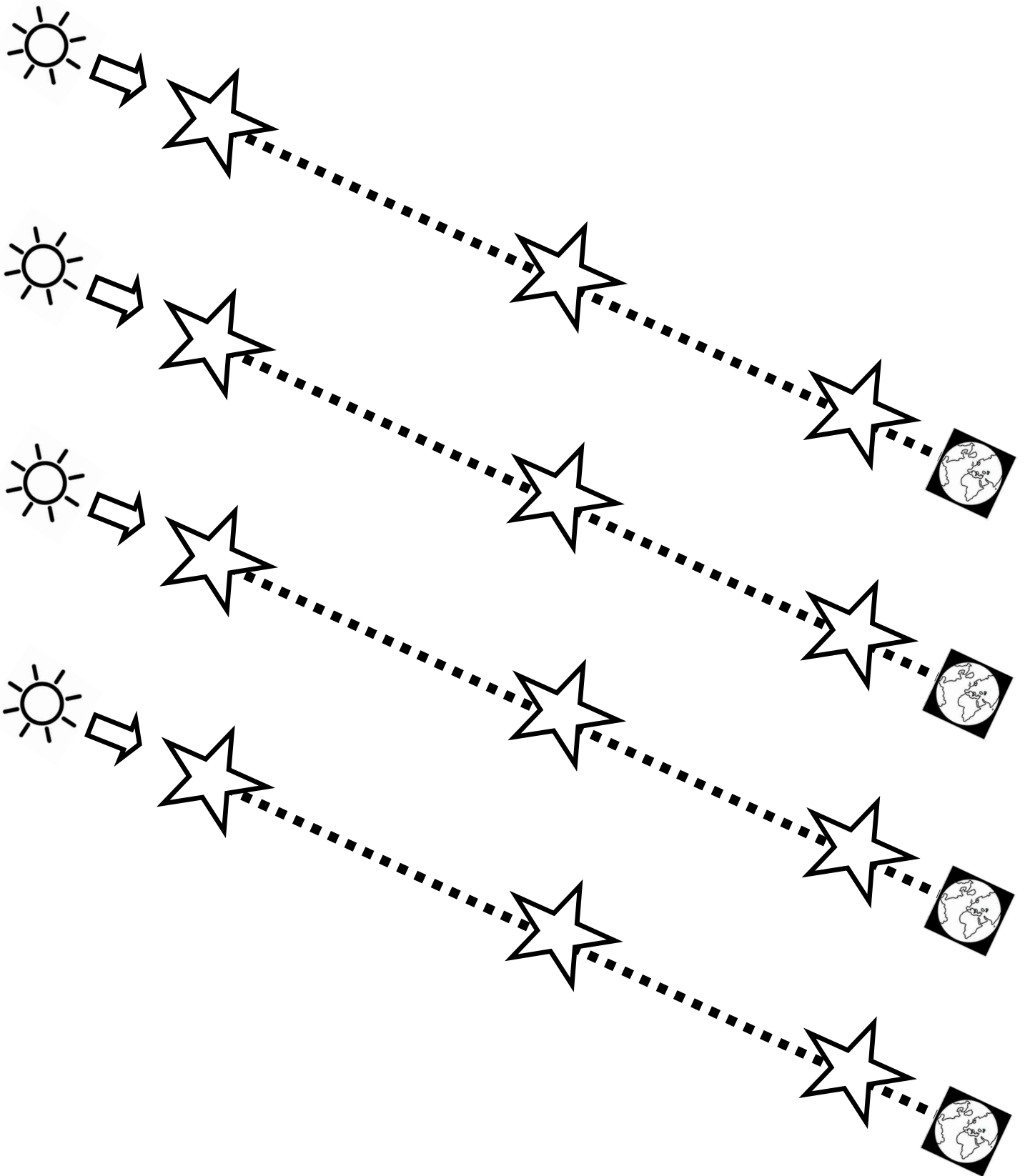

# Actividades para mejorar motricidad fina

Sigue con tu lápiz las estrellitas para ir desde el sol a la tierra

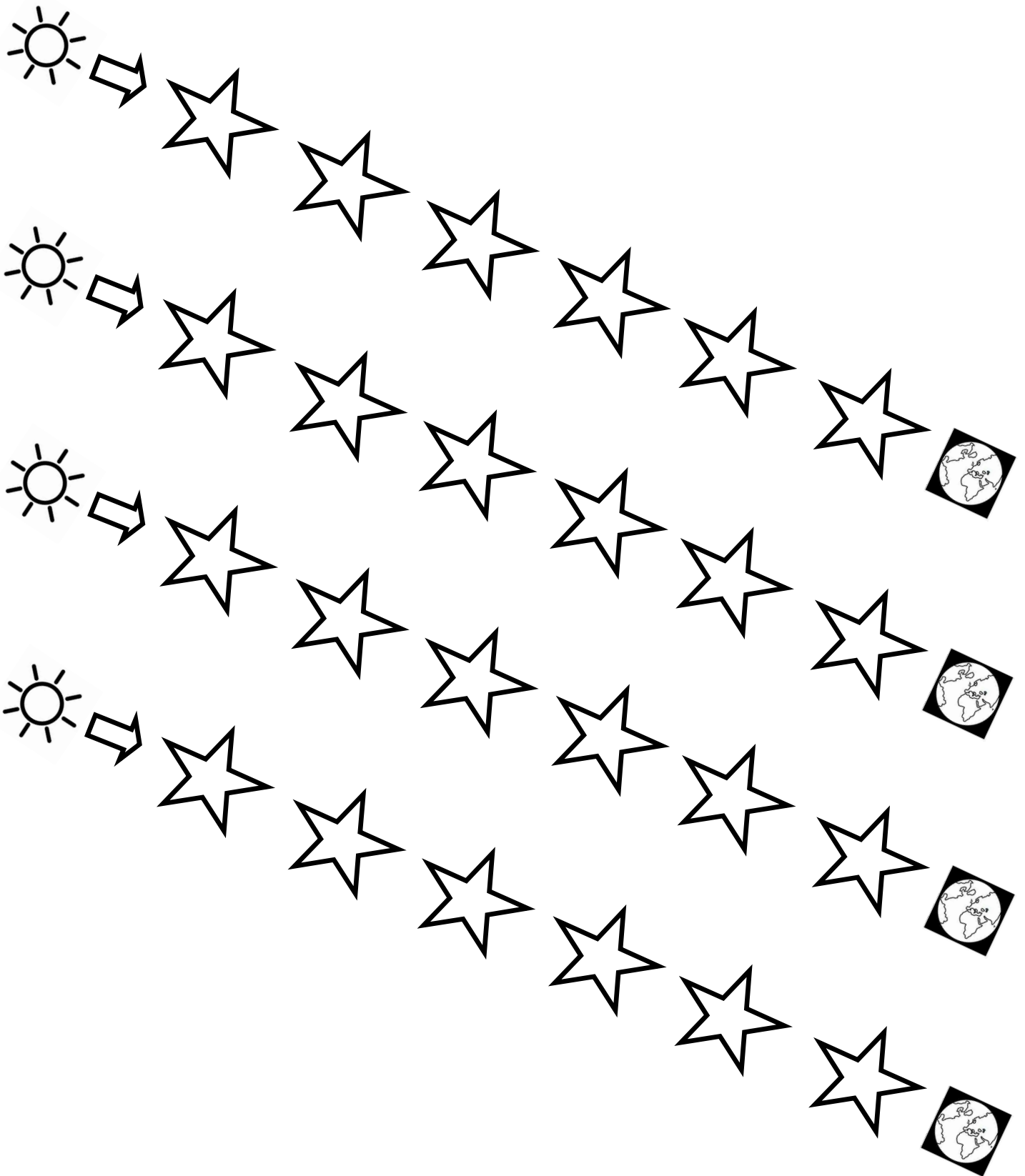

# Actividades para mejorar motricidad fina

Sigue con tu lápiz las estrellitas para ir desde el sol a la tierra

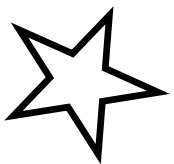
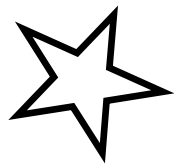
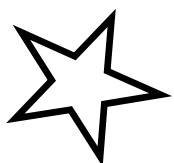
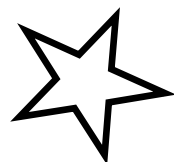
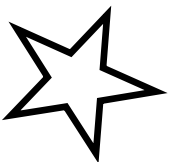
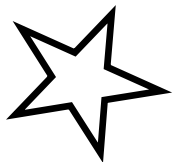
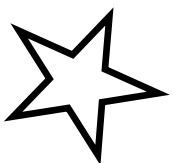
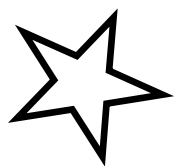
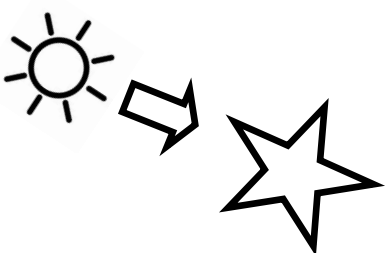
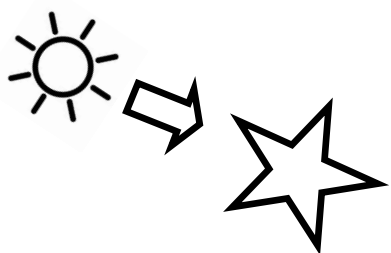
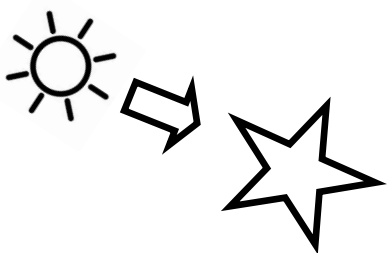
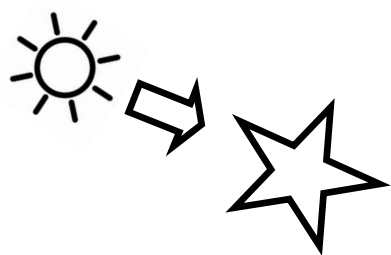



# Actividades para mejorar motricidad fina

Sigue con tu lápiz los corazones para unir a la mama y a su bebe

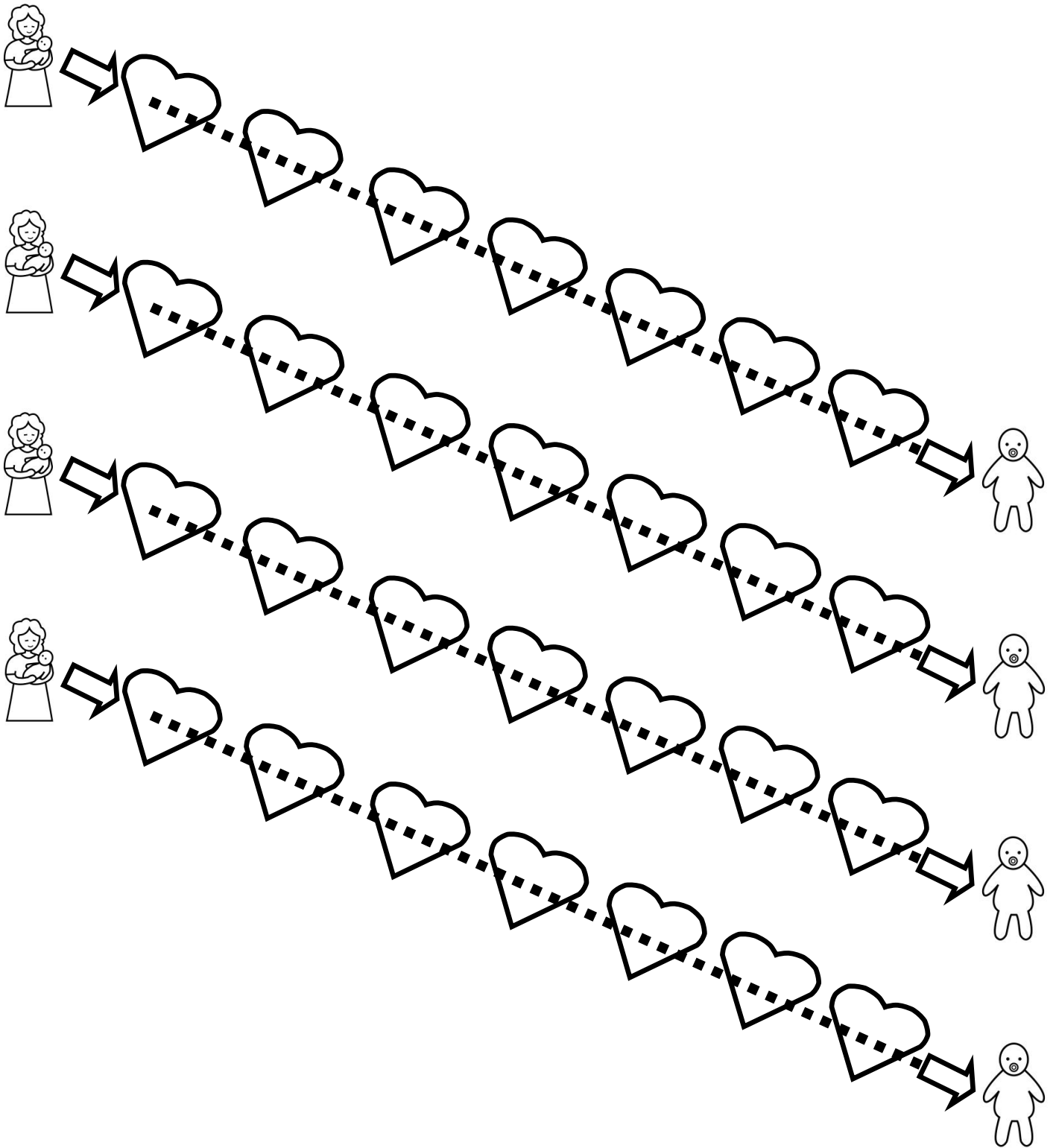

# Actividades para mejorar motricidad fina

Sigue con tu lápiz los corazones para unir a la mama y a su bebe

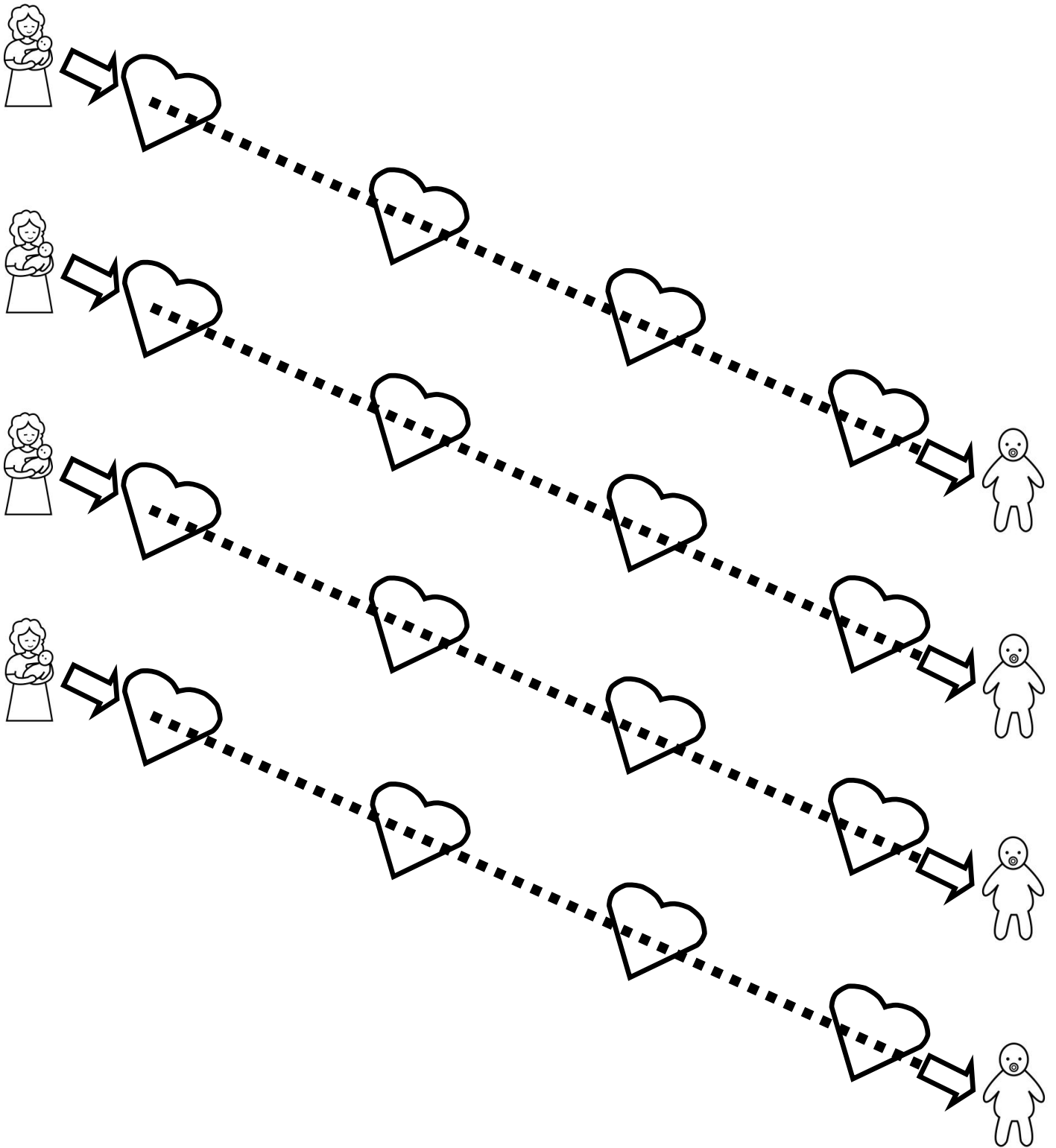

# Actividades para mejorar motricidad fina

Sigue con tu lápiz los corazones para unir a la mama y a su bebe

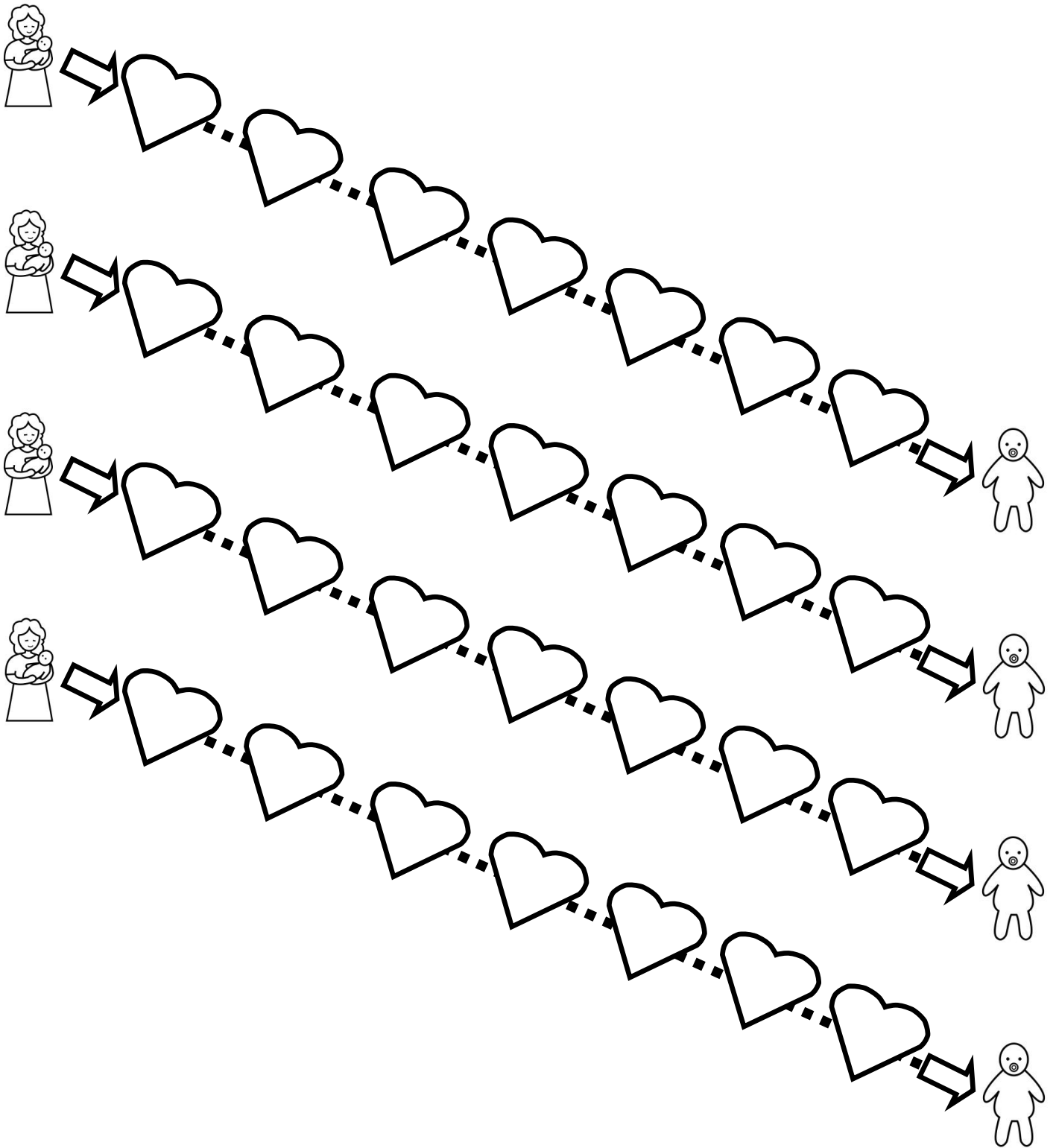

# Actividades para mejorar motricidad fina

Sigue con tu lápiz los corazones para unir a la mama y a su bebe

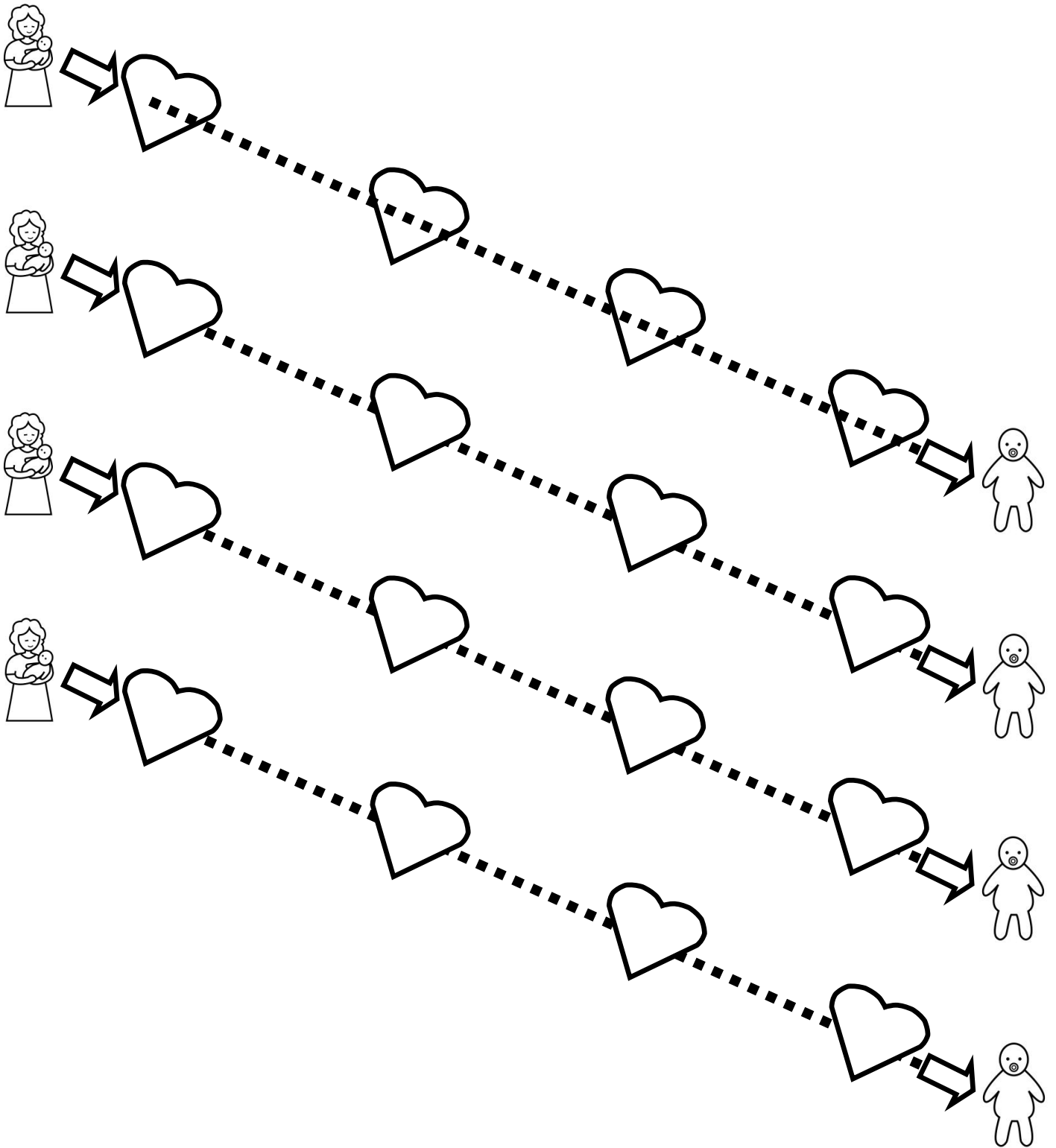

# Actividades para mejorar motricidad fina

Sigue con tu lápiz los corazones para unir a la mama y a su bebe

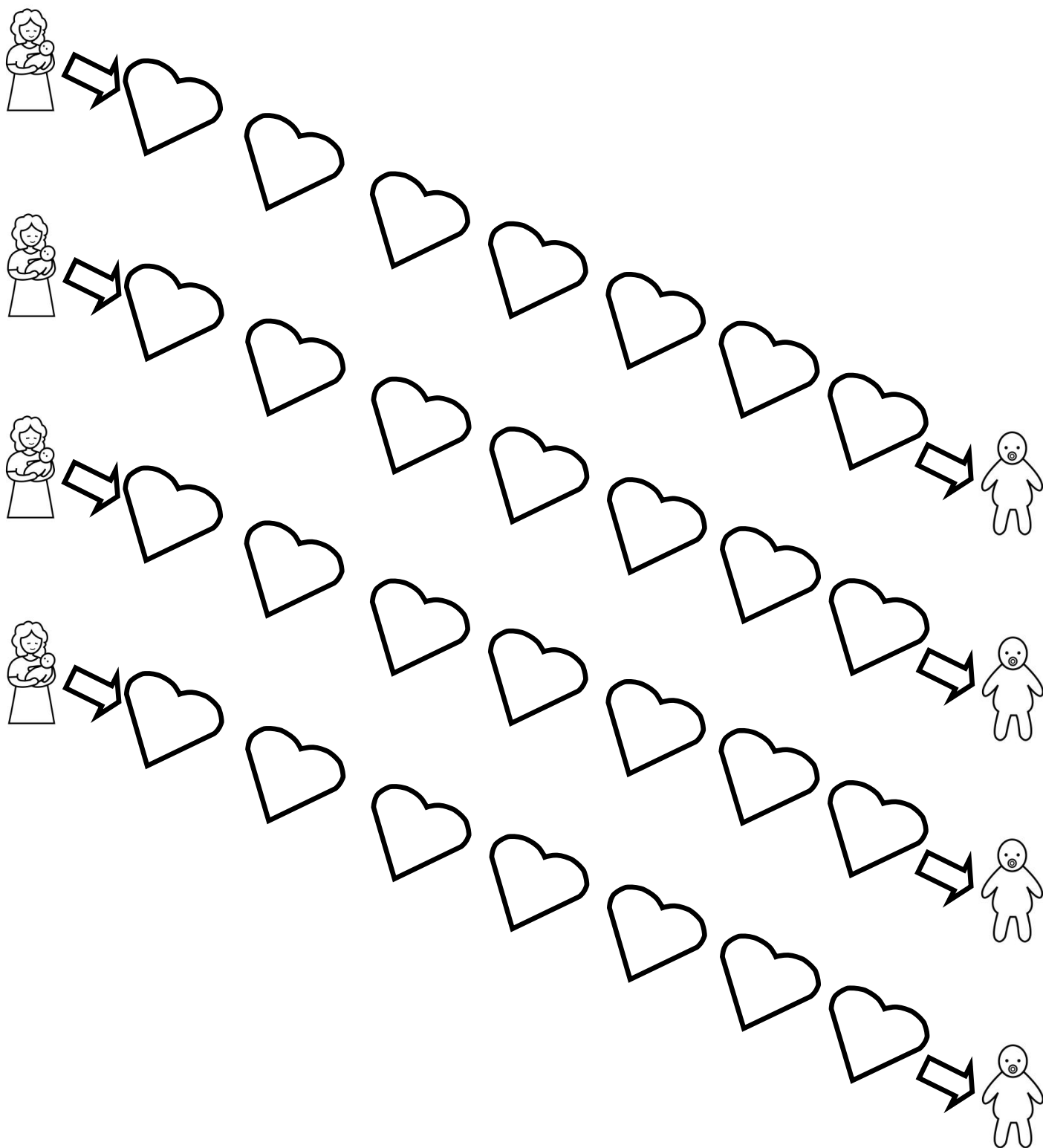

# Actividades para mejorar motricidad fina

Sigue con tu lápiz los corazones para unir a la mama y a su bebe

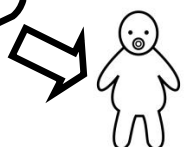
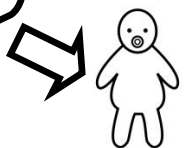
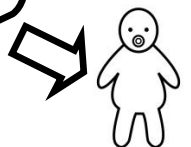
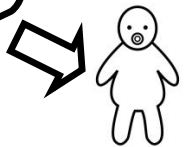
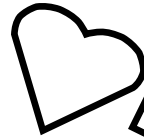
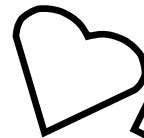
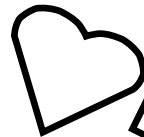
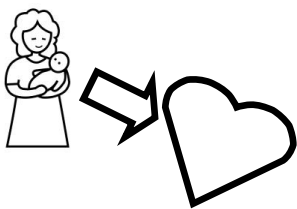
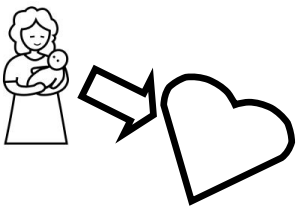
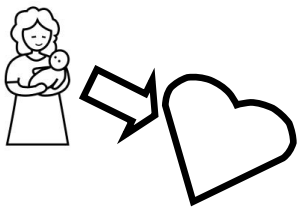
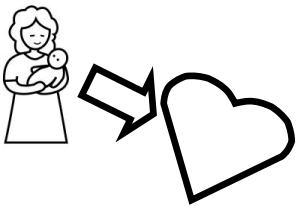



# Actividades para mejorar motricidad fina

Sigue con tu lápiz las caras para unir al niño con su amiga

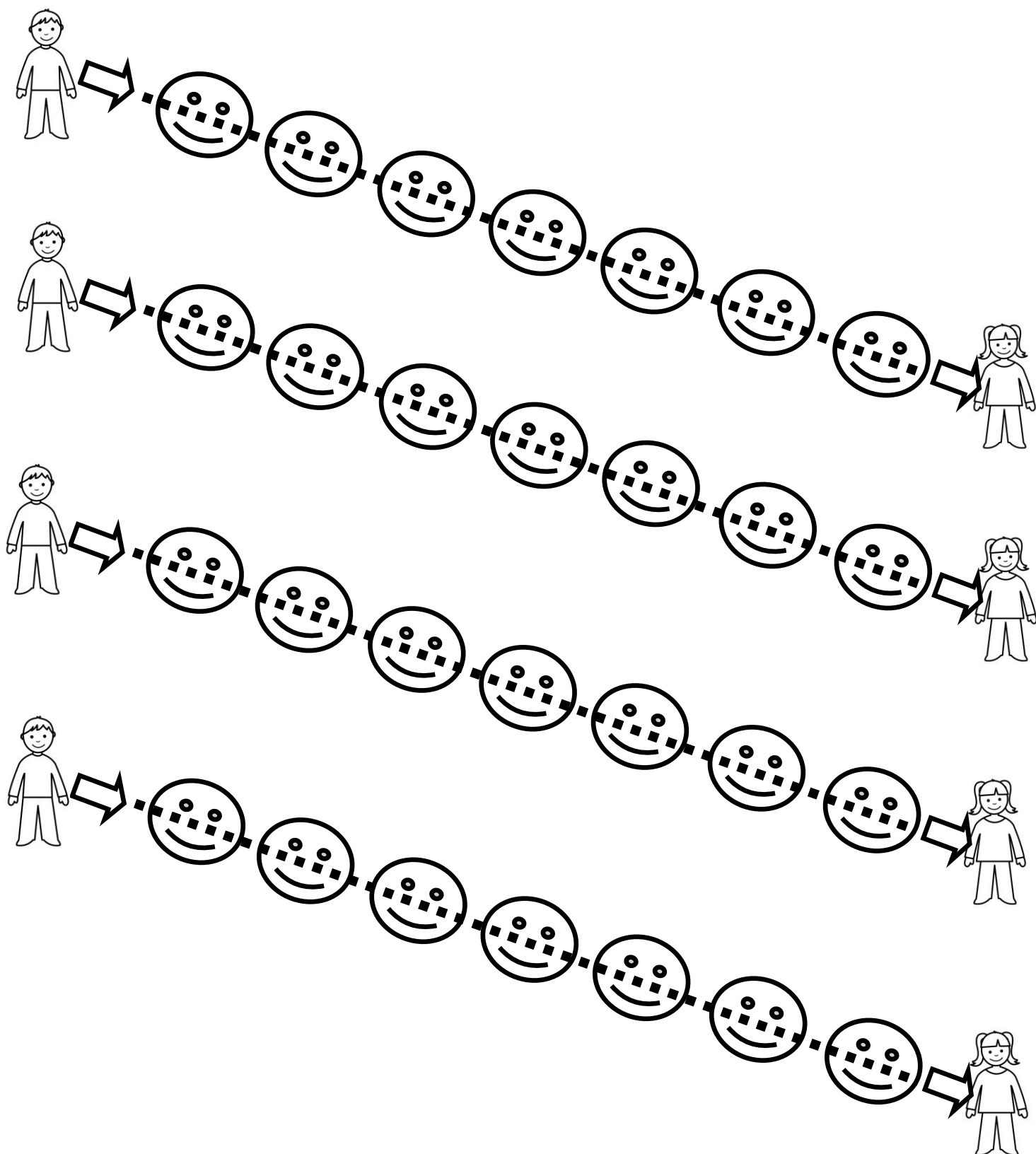



# Actividades para mejorar motricidad fina

Sigue con tu lápiz las caras para unir al niño con su amiga

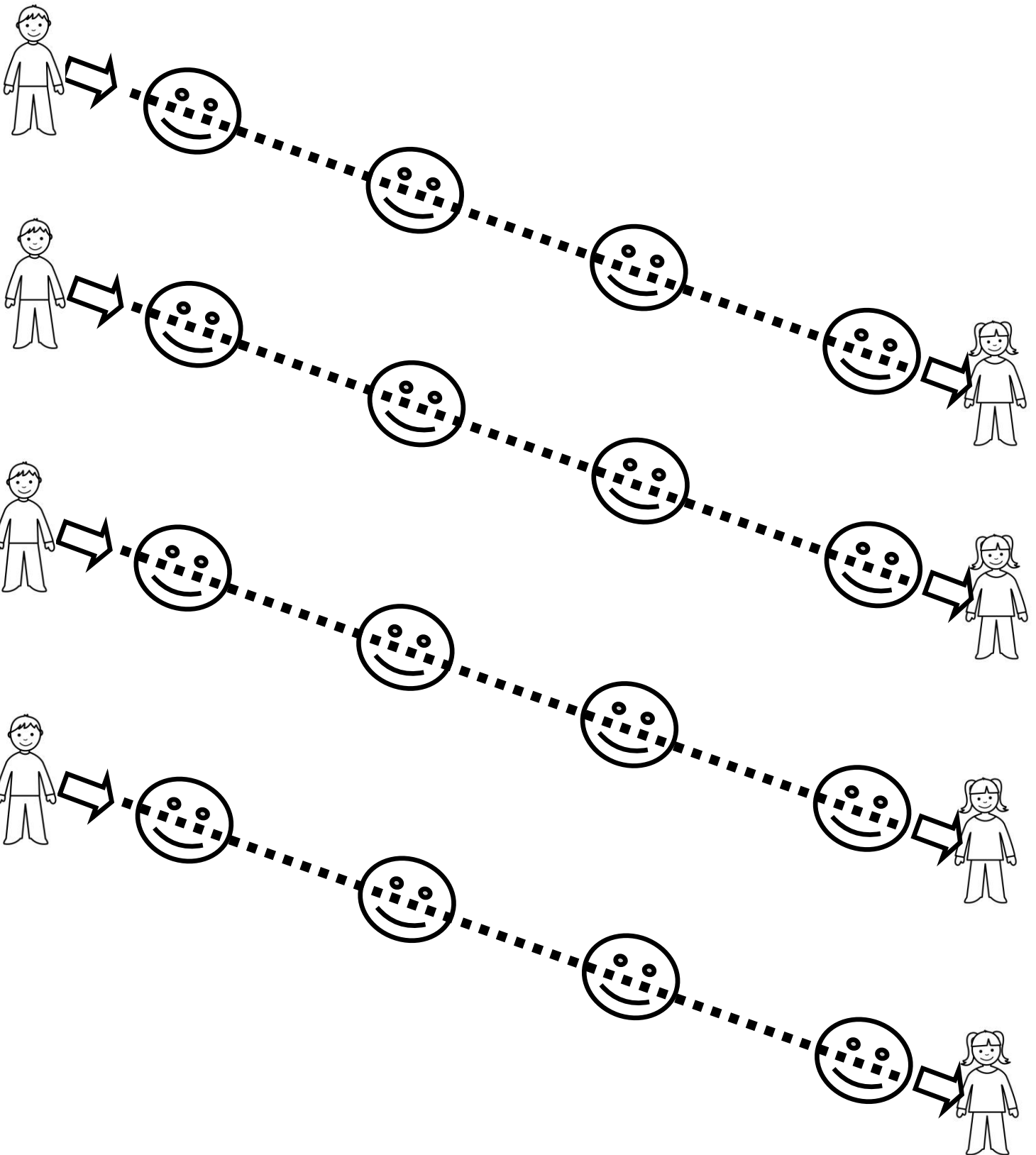

# Actividades para mejorar motricidad fina

Sigue con tu lápiz las caras para unir al niño con su amiga

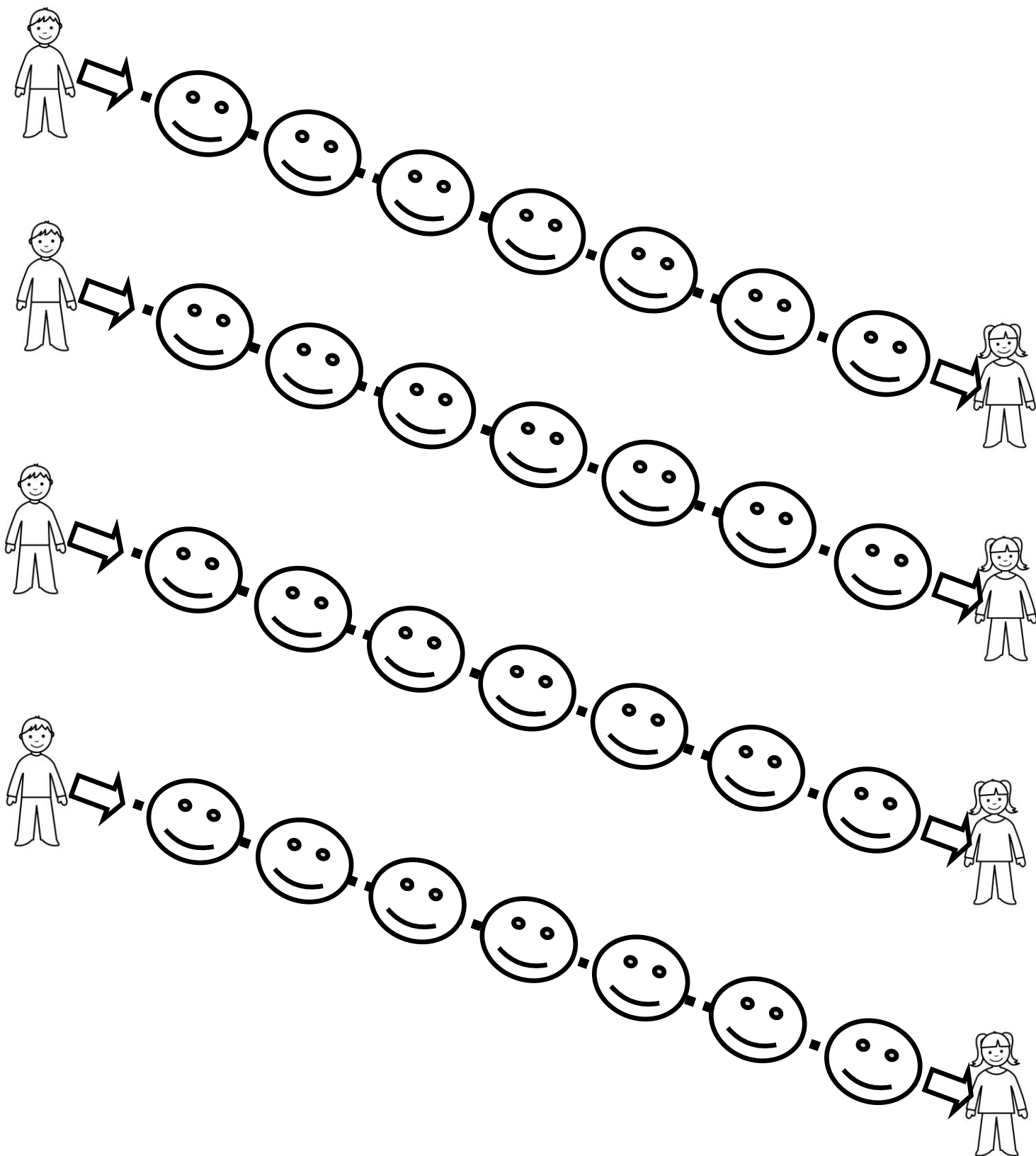

# Actividades para mejorar motricidad fina

Sigue con tu lápiz las caras para unir al niño con su amiga

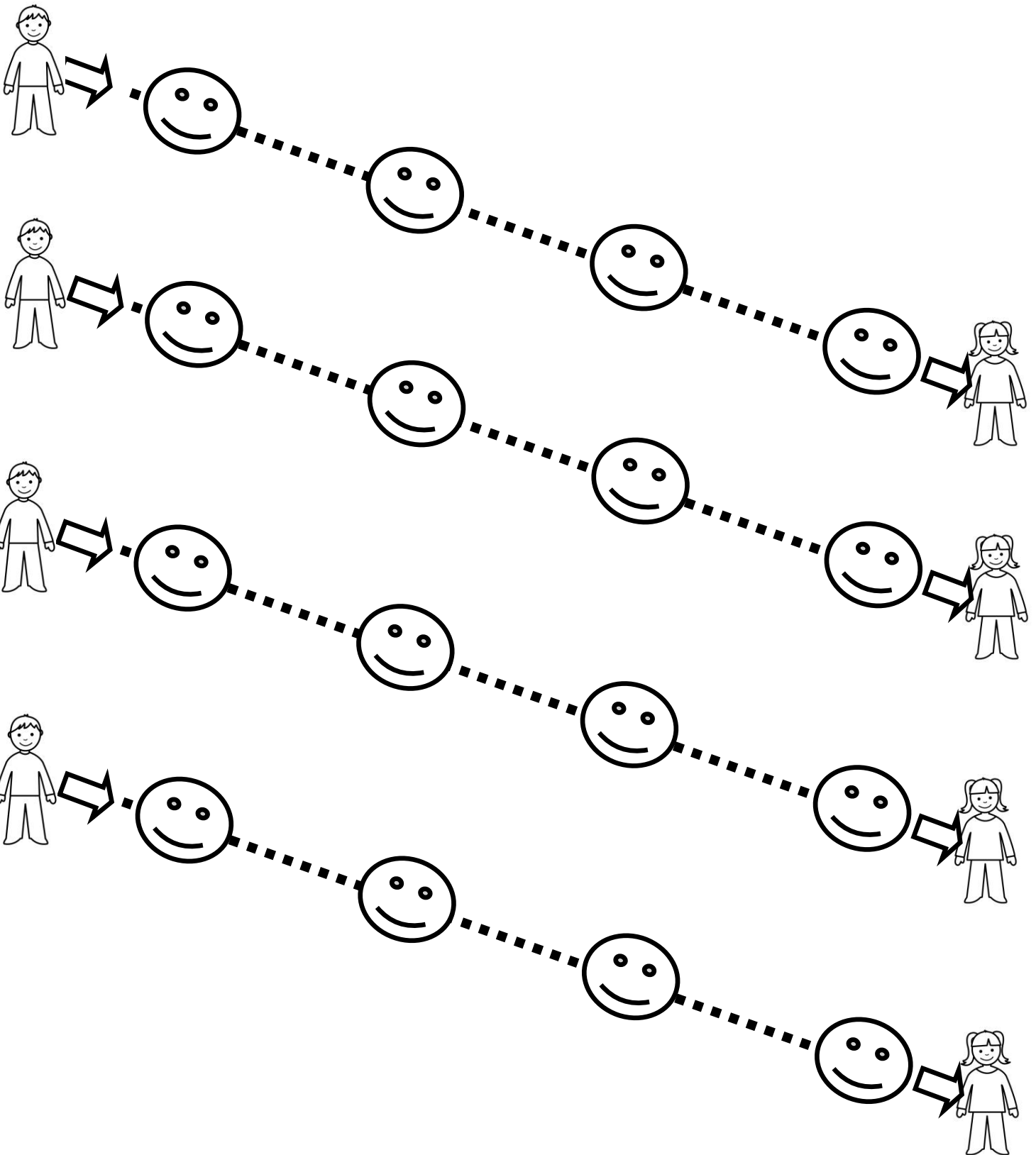

## Actividades para mejorar motricidad fina

Sigue con tu lápiz las caras para unir al niño con su amiga

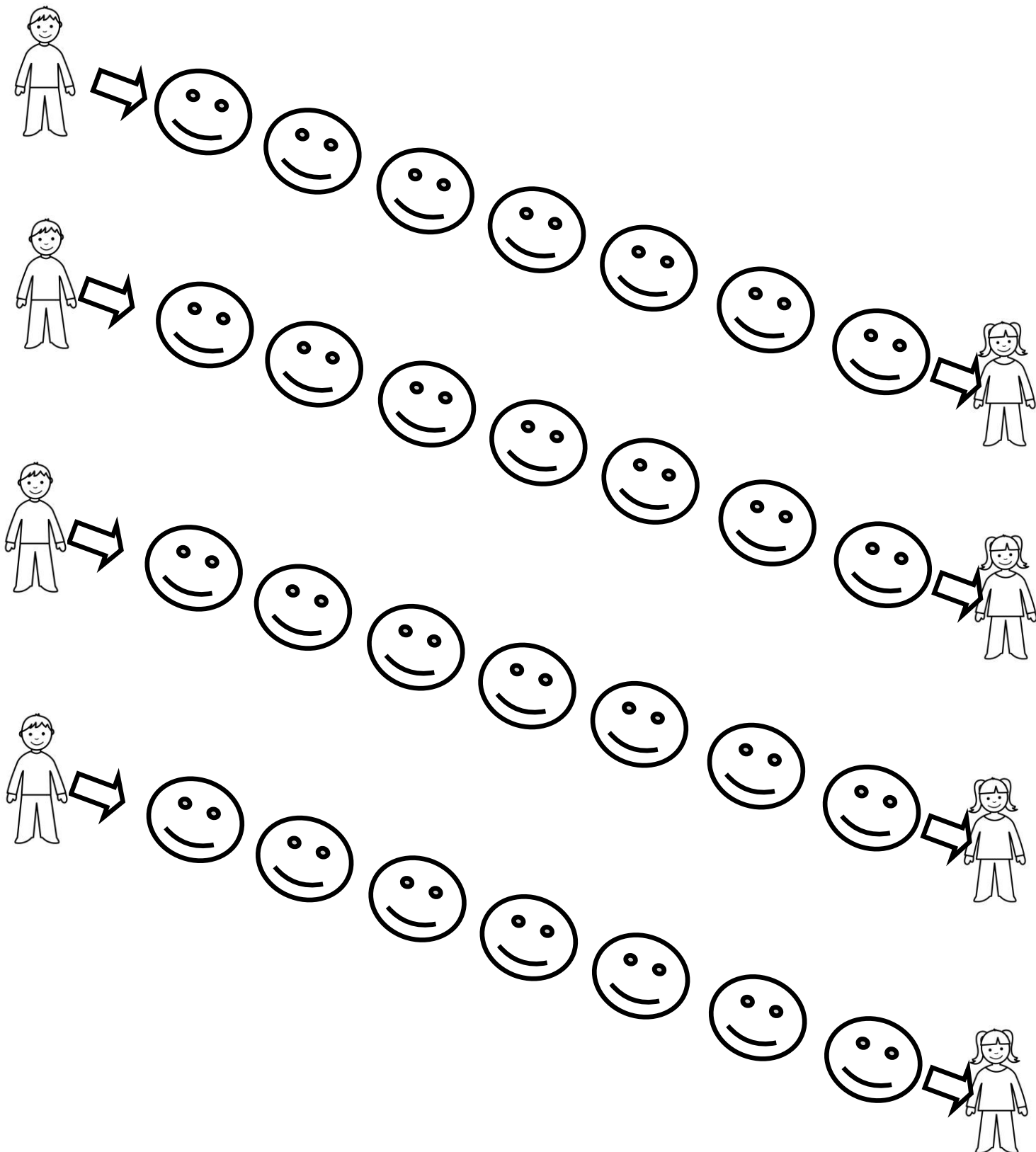

# Actividades para mejorar motricidad fina

Sigue con tu lápiz las caras para unir al niño con su amiga

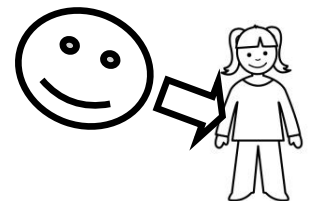
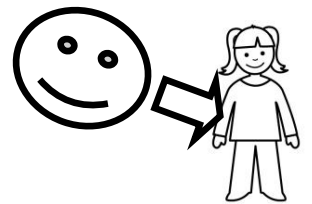
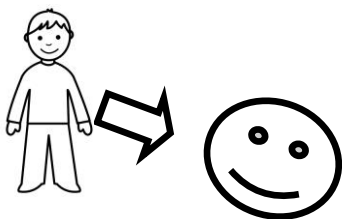
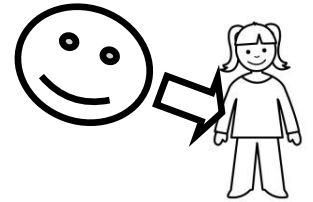
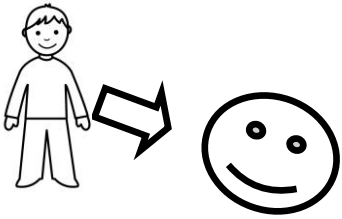
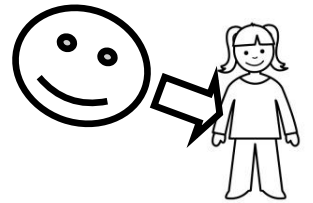
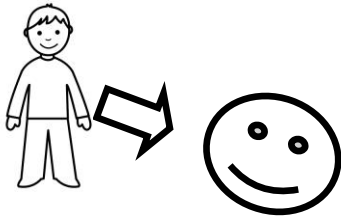
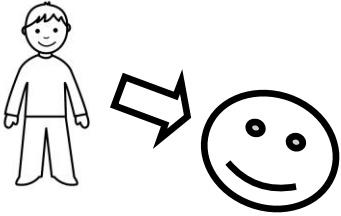

# Actividades para mejorar motricidad fina

Sigue con tu lápiz los círculos para unir al niño con su pelota

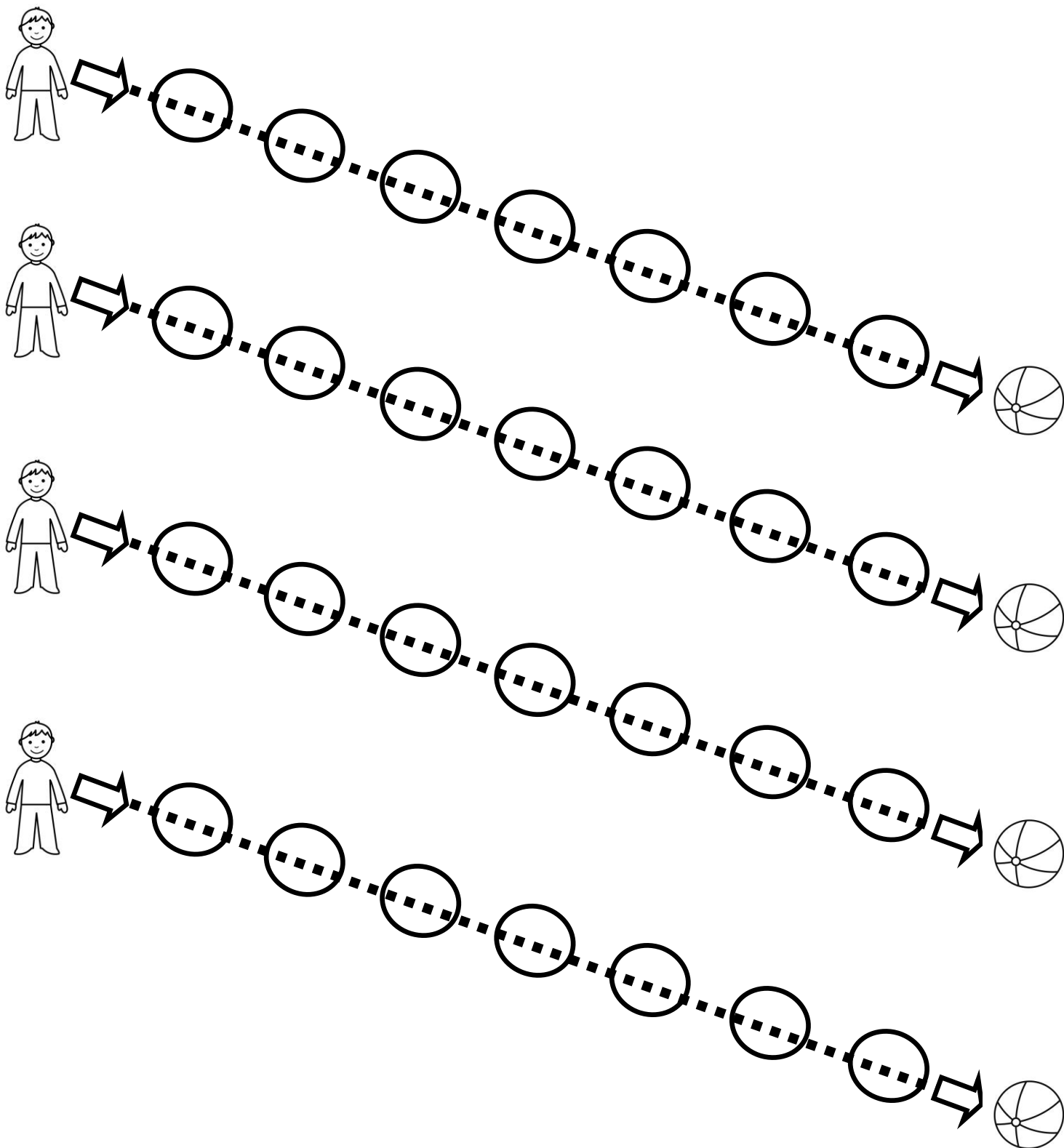

# Actividades para mejorar motricidad fina

Sigue con tu lápiz los círculos para unir al niño con su pelota

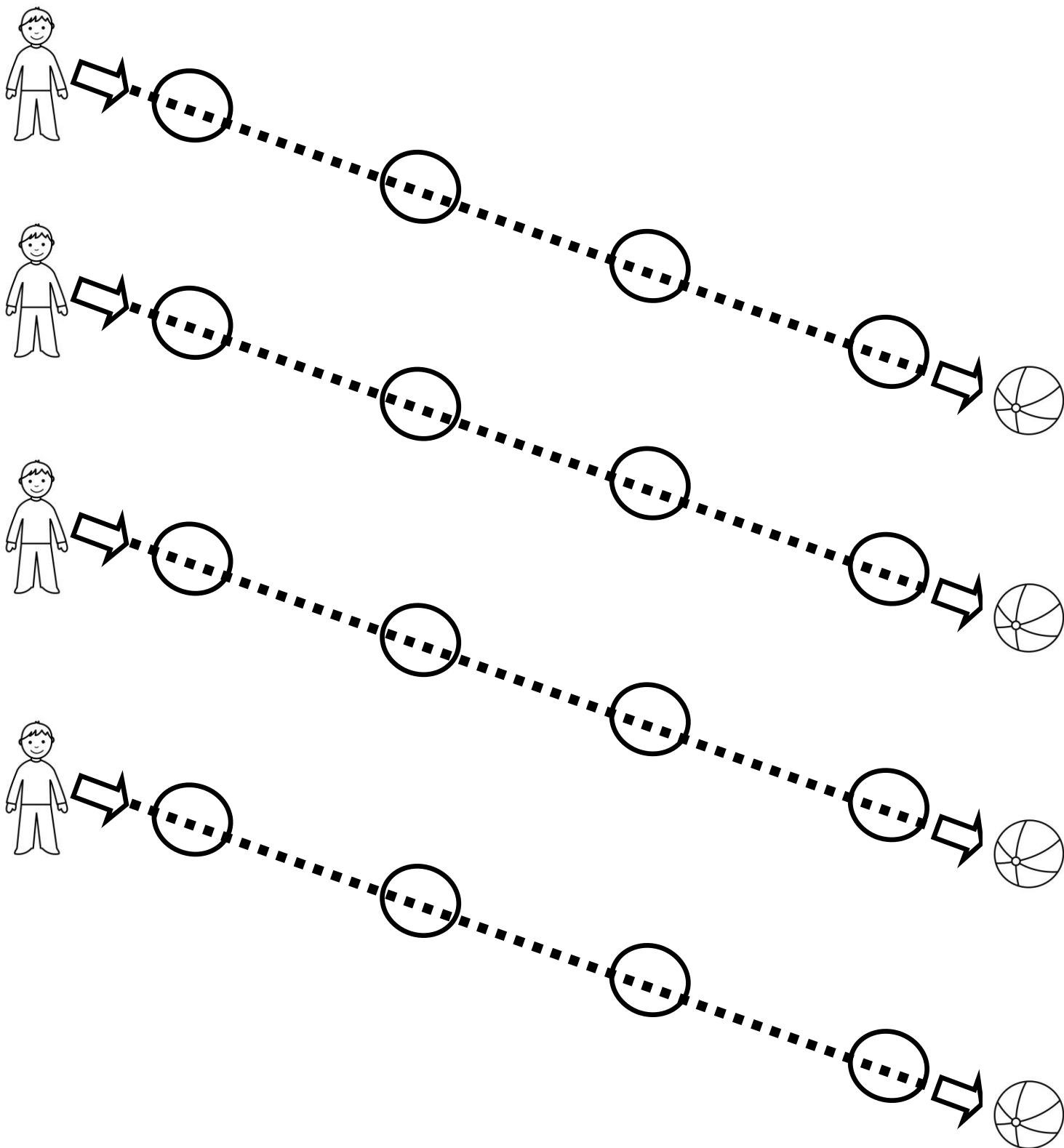

# Actividades para mejorar motricidad fina

Sigue con tu lápiz los círculos para unir al niño con su pelota

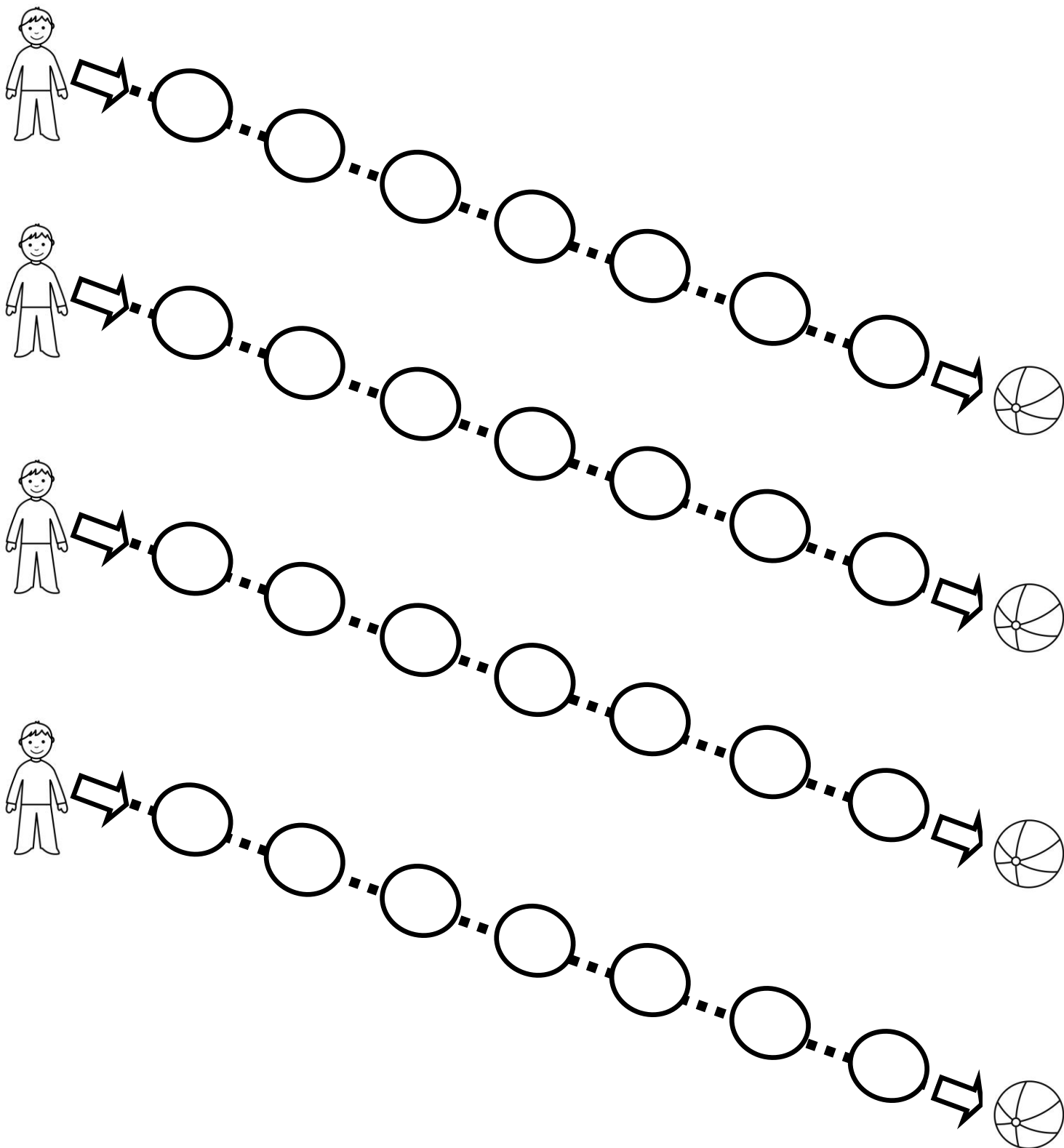



# Actividades para mejorar motricidad fina

Sigue con tu lápiz los círculos para unir al niño con su pelota

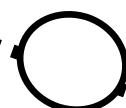
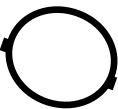
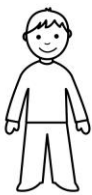
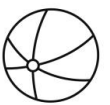
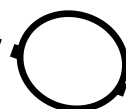
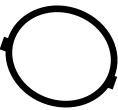
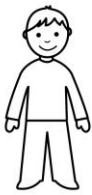
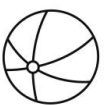
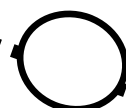
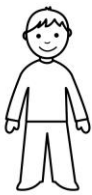
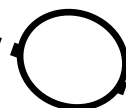
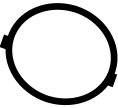
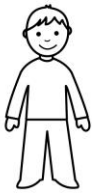

# Actividades para mejorar motricidad fina

Sigue con tu lápiz los círculos para unir al niño con su pelota

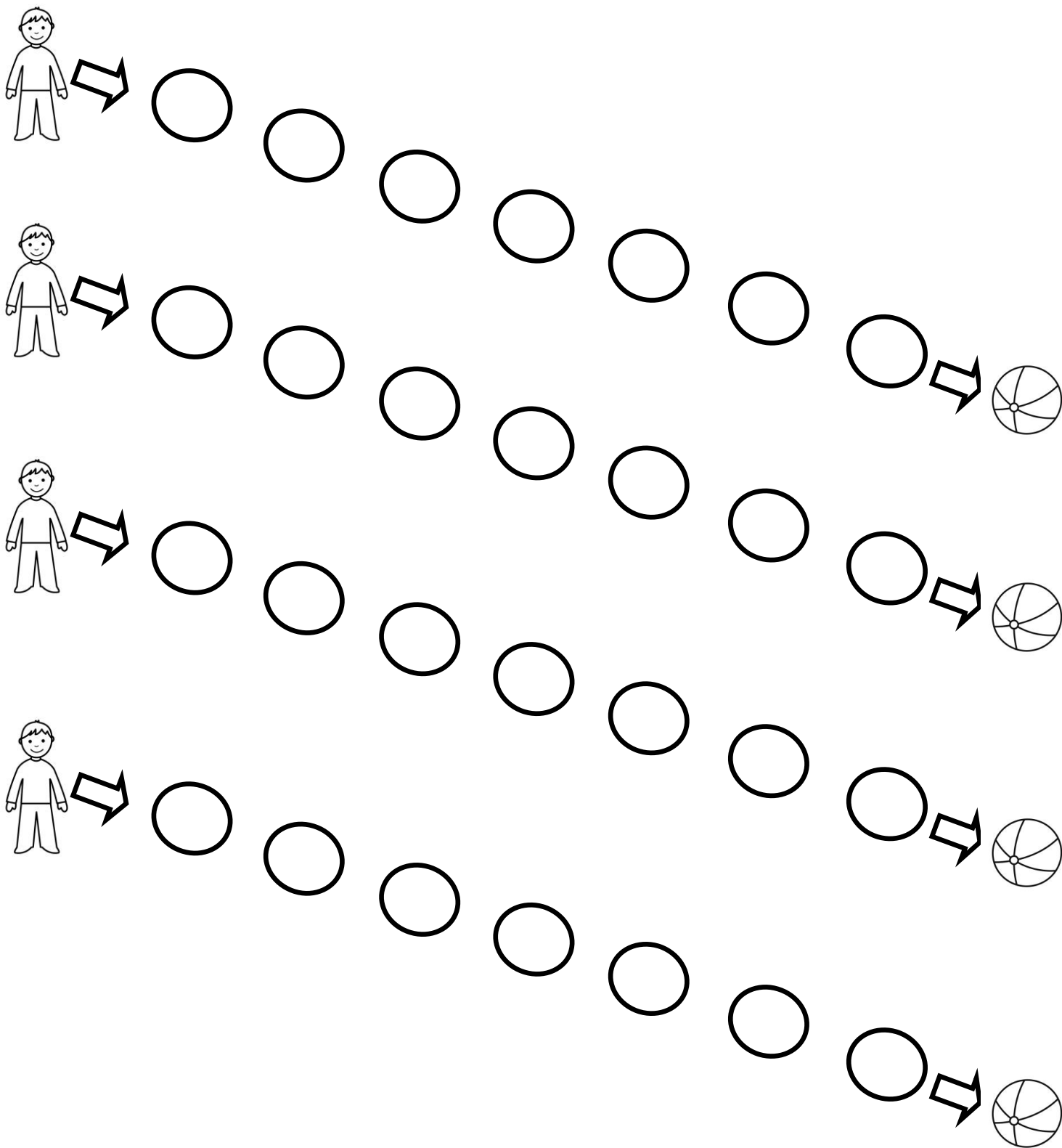

# Actividades para mejorar motricidad fina

Sigue con tu lápiz los círculos para unir al niño con su pelota

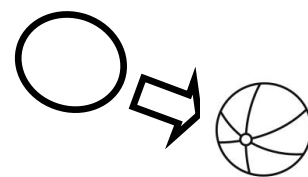
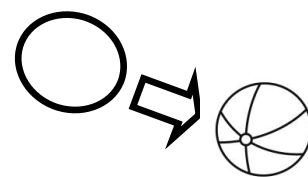
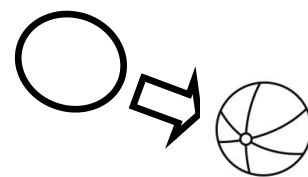
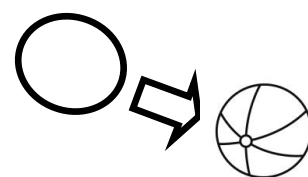
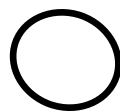
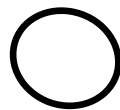
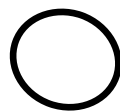
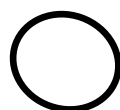
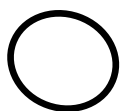
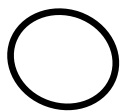
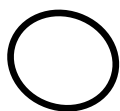
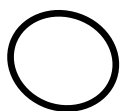
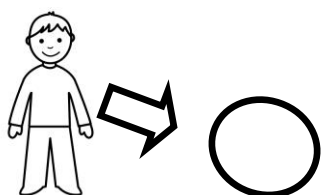
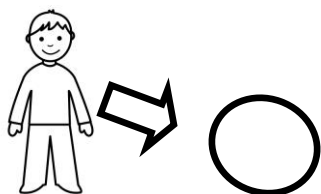
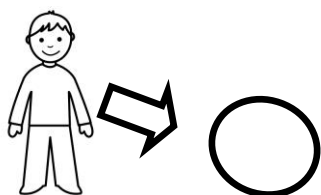
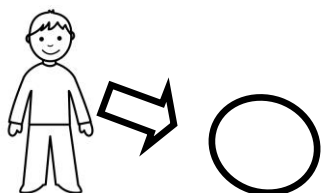

# Actividades para mejorar motricidad fina

Sigue con tu lápiz las estrellitas para ir desde el sol a la tierra

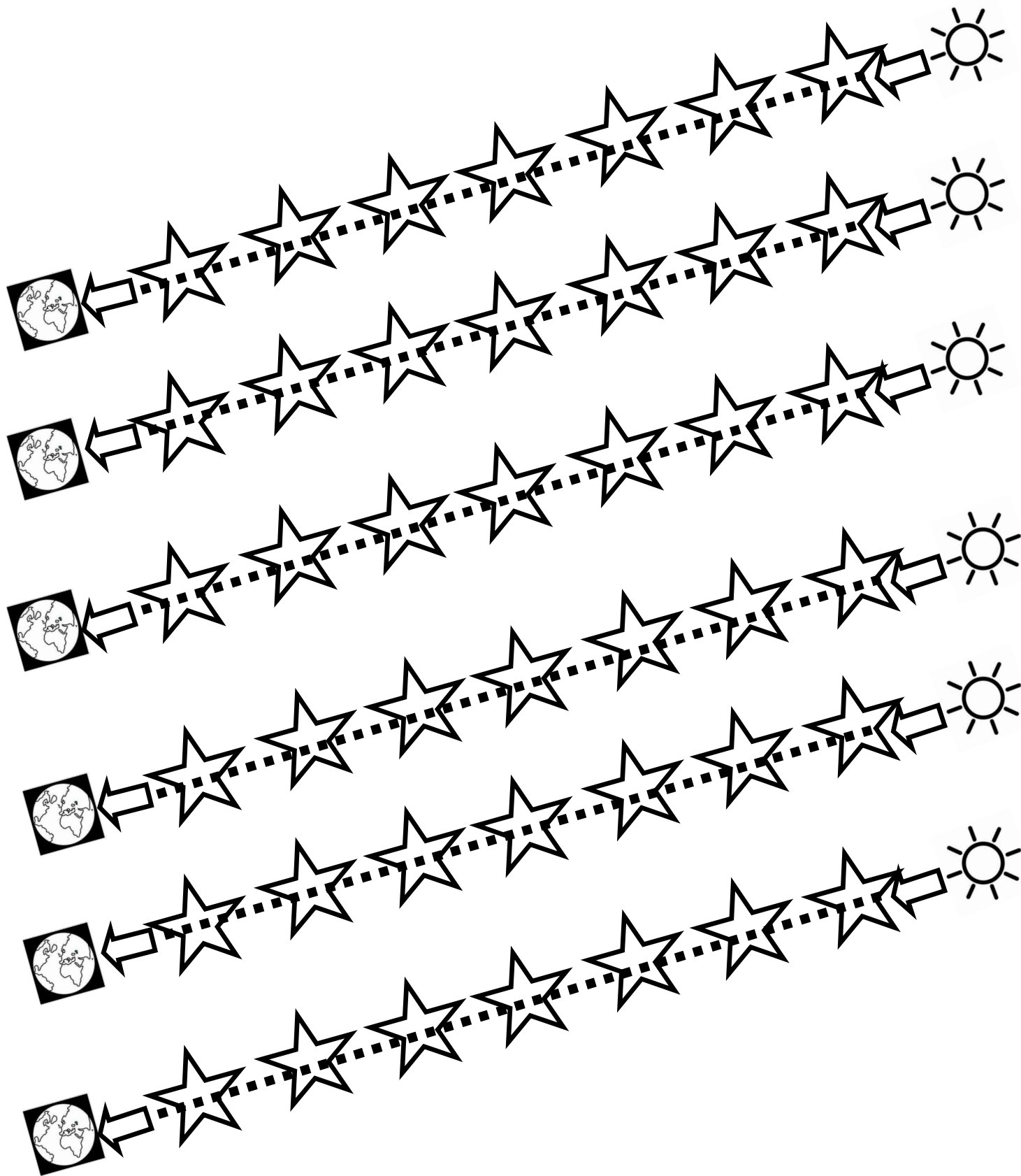

# Actividades para mejorar motricidad fina

Sigue con tu lápiz las estrellitas para ir desde el sol a la tierra

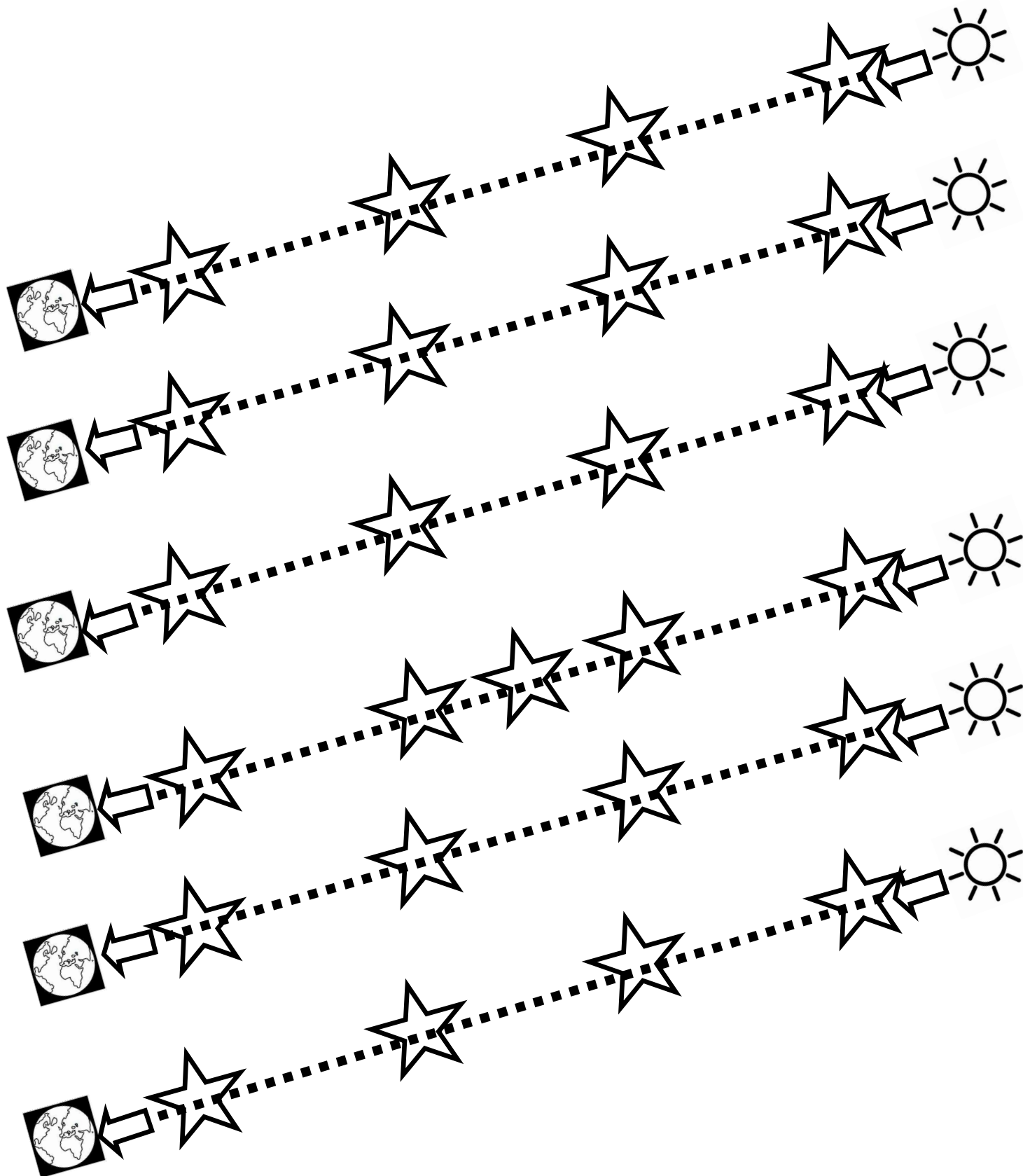

# Actividades para mejorar motricidad fina

Sigue con tu lápiz las estrellitas para ir desde el sol a la tierra

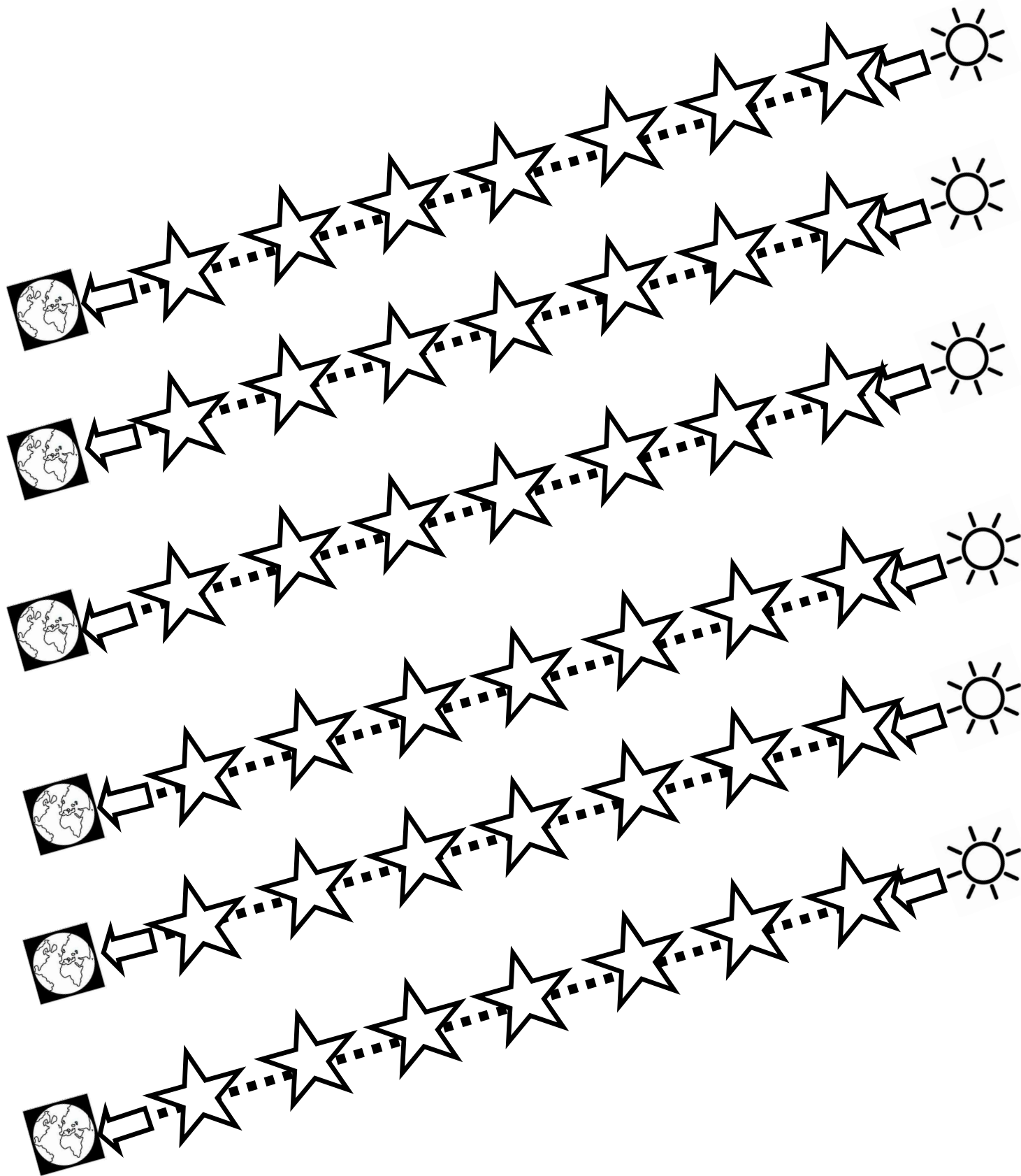

# Actividades para mejorar motricidad fina

Sigue con tu lápiz las estrellitas para ir desde el sol a la tierra

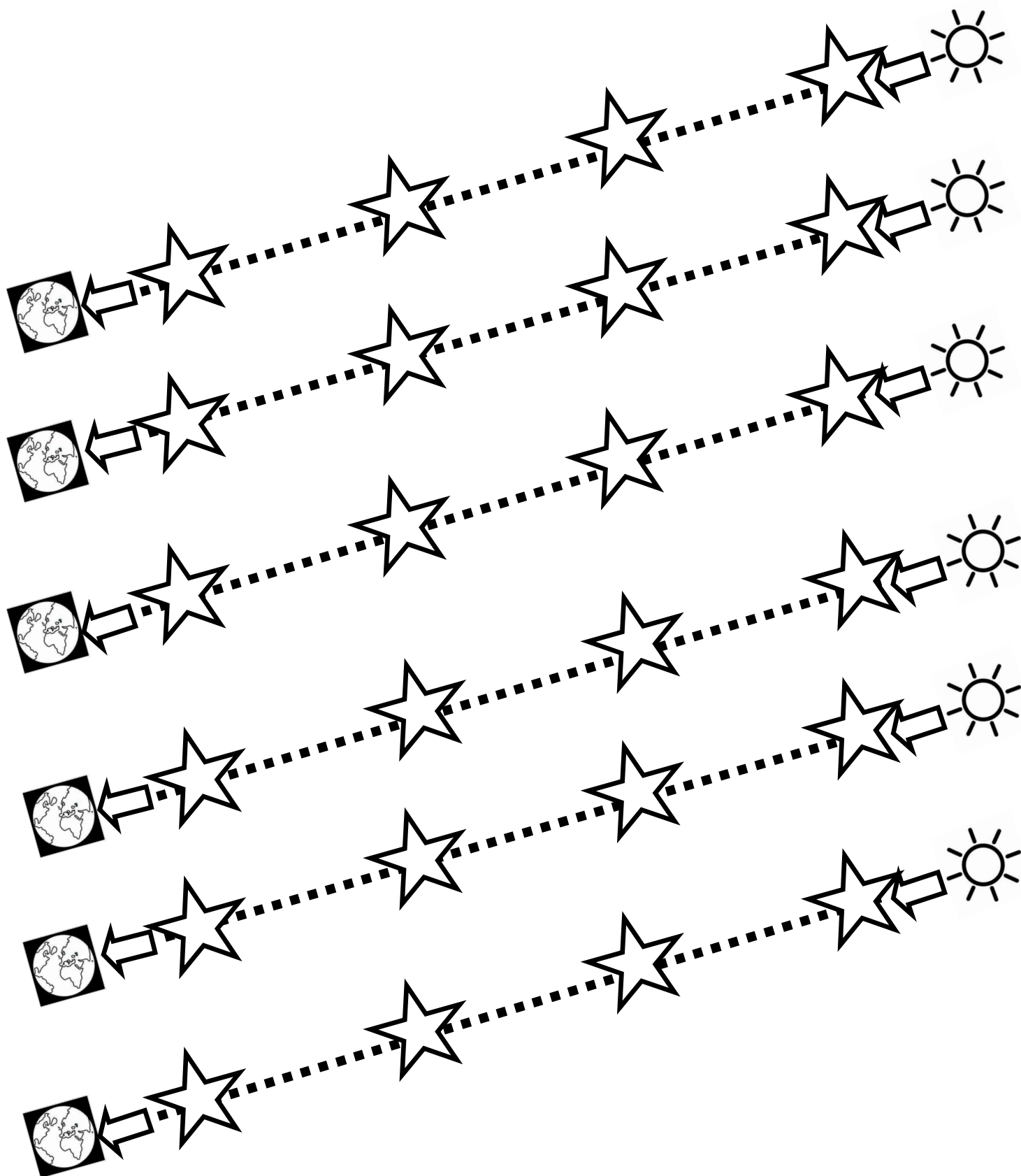

# Actividades para mejorar motricidad fina

Sigue con tu lápiz las estrellitas para ir desde el sol a la tierra

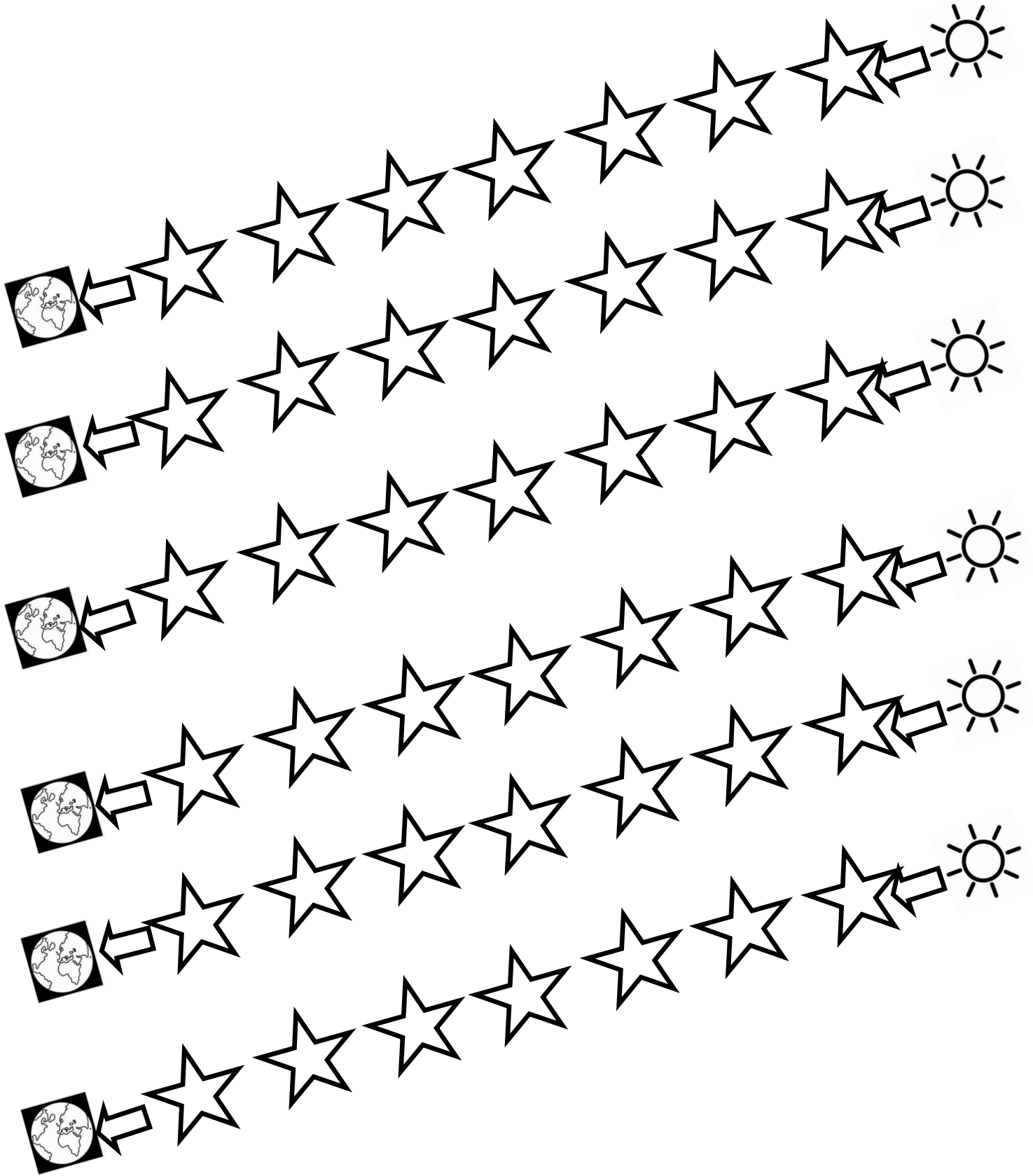



# Actividades para mejorar motricidad fina

Sigue con tu lápiz las estrellitas para ir desde el sol a la tierra

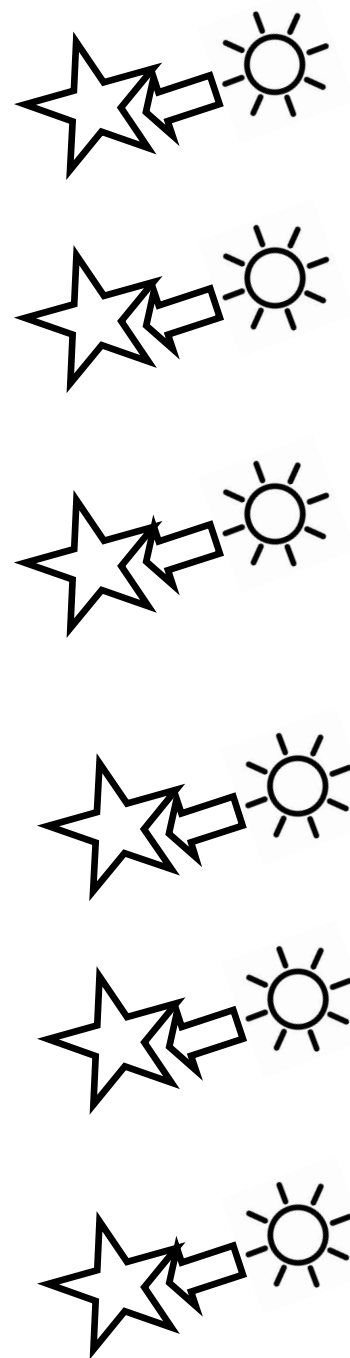
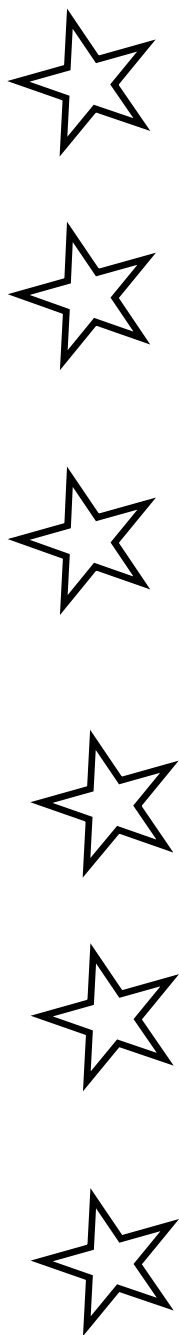
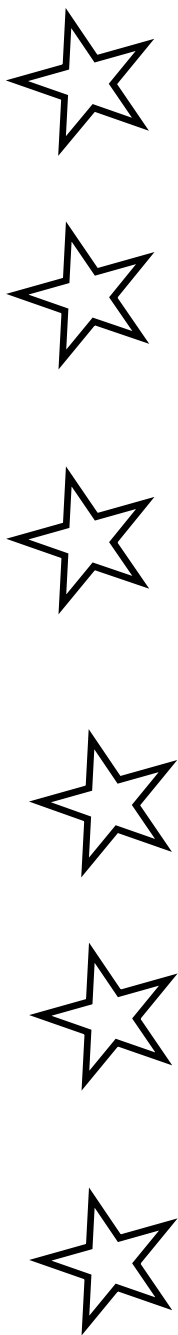
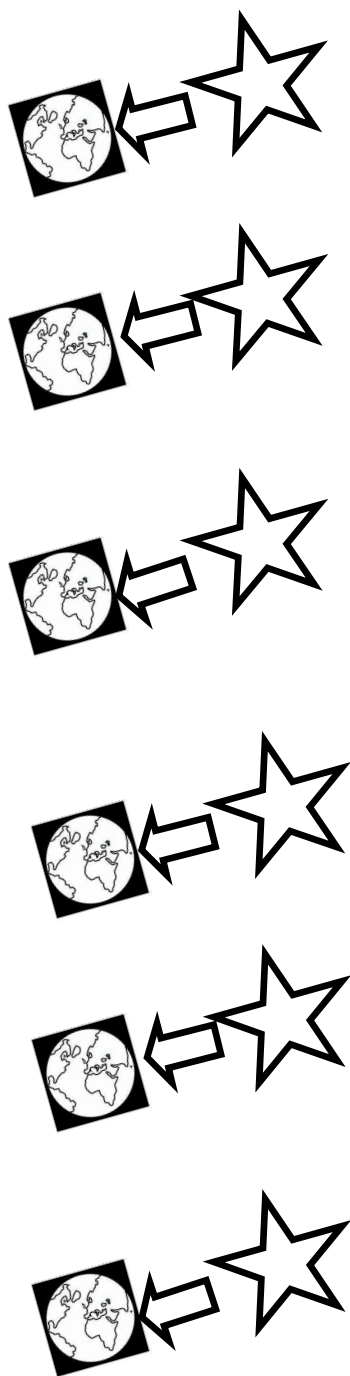

# Actividades para mejorar motricidad fina

Sigue con tu lápiz los corazones para unir a la mama y a su bebe

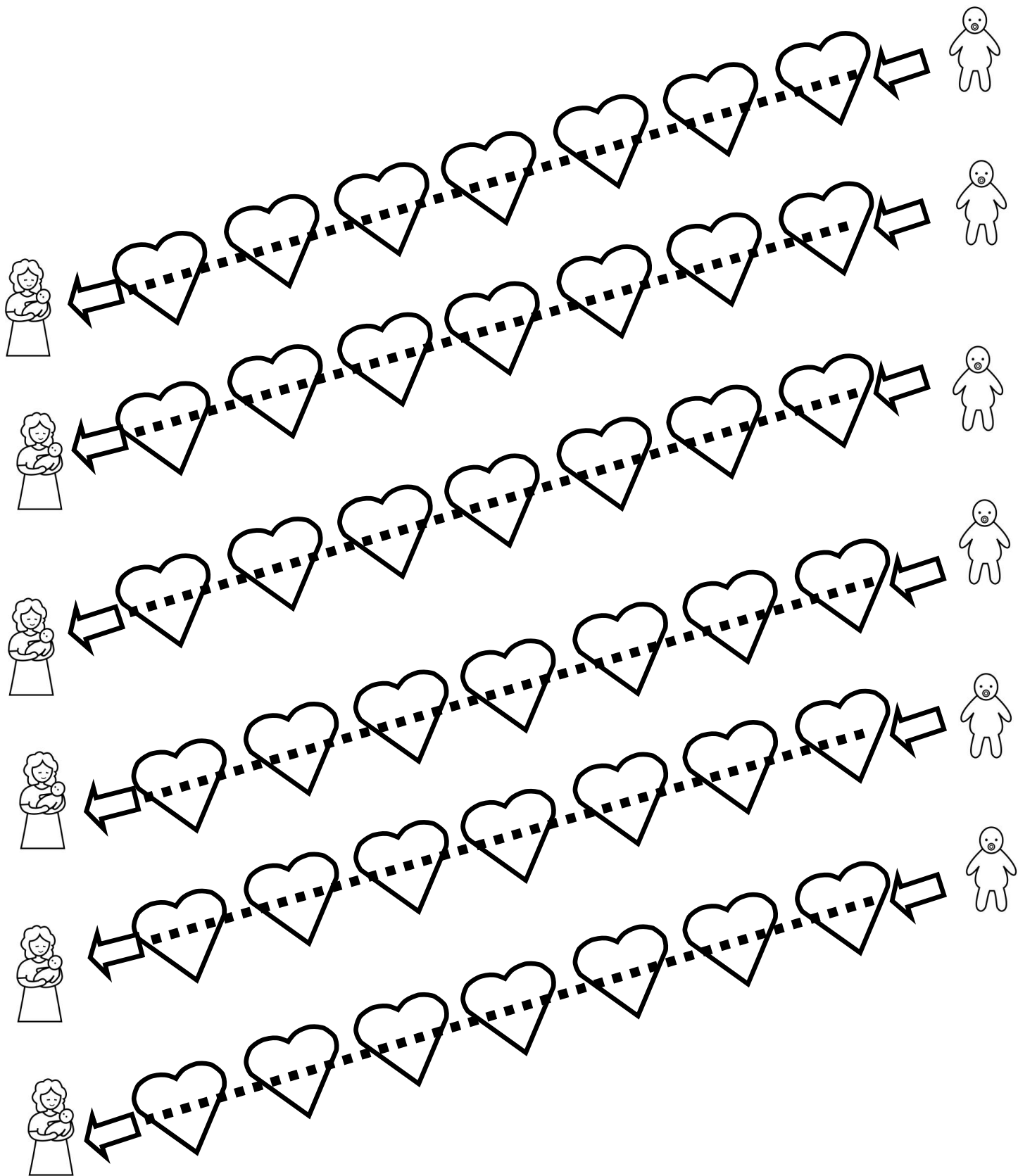

# Actividades para mejorar motricidad fina

Sigue con tu lápiz los corazones para unir a la mama y a su bebe

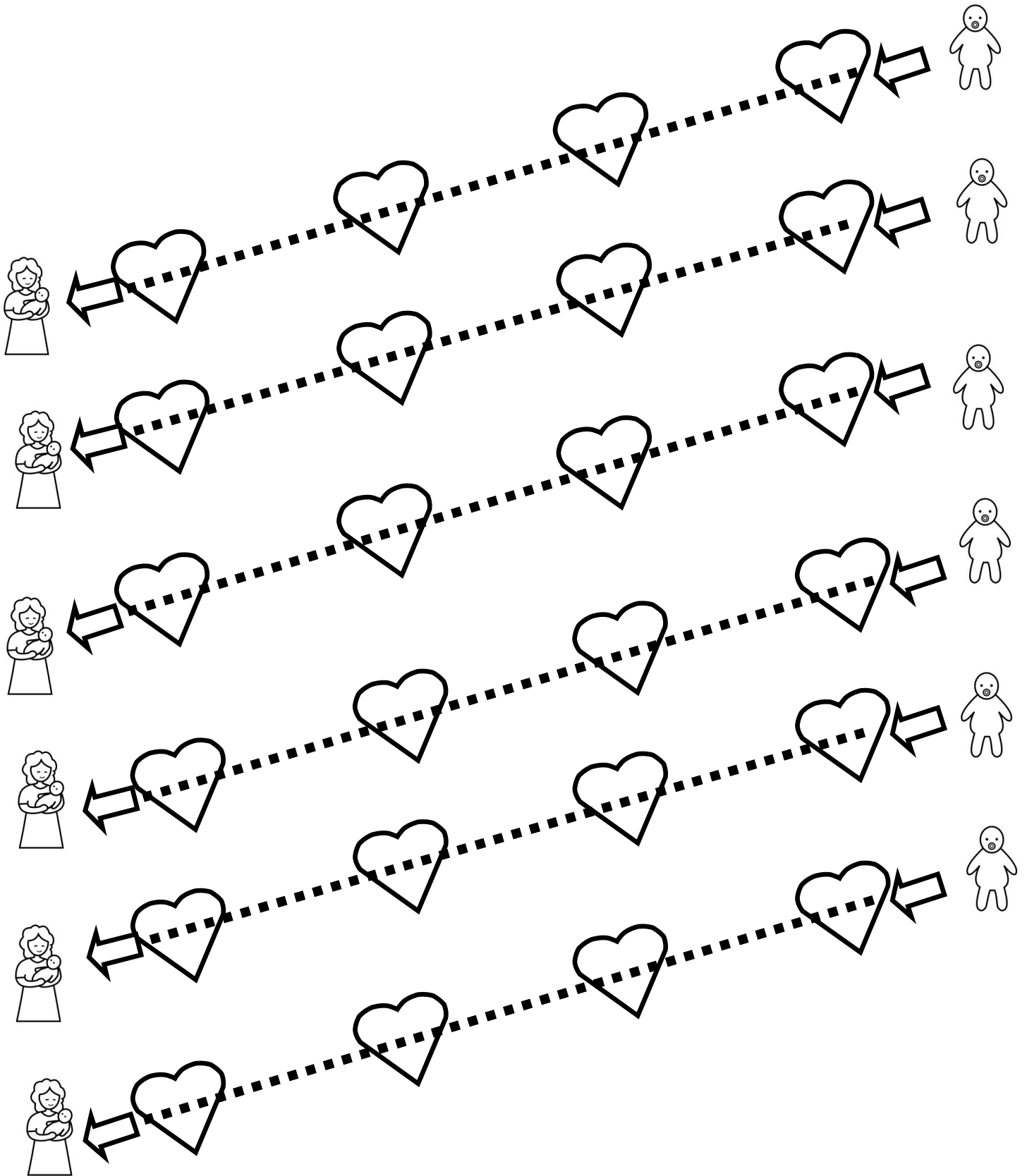

# Actividades para mejorar motricidad fina

Sigue con tu lápiz los corazones para unir a la mama y a su bebe

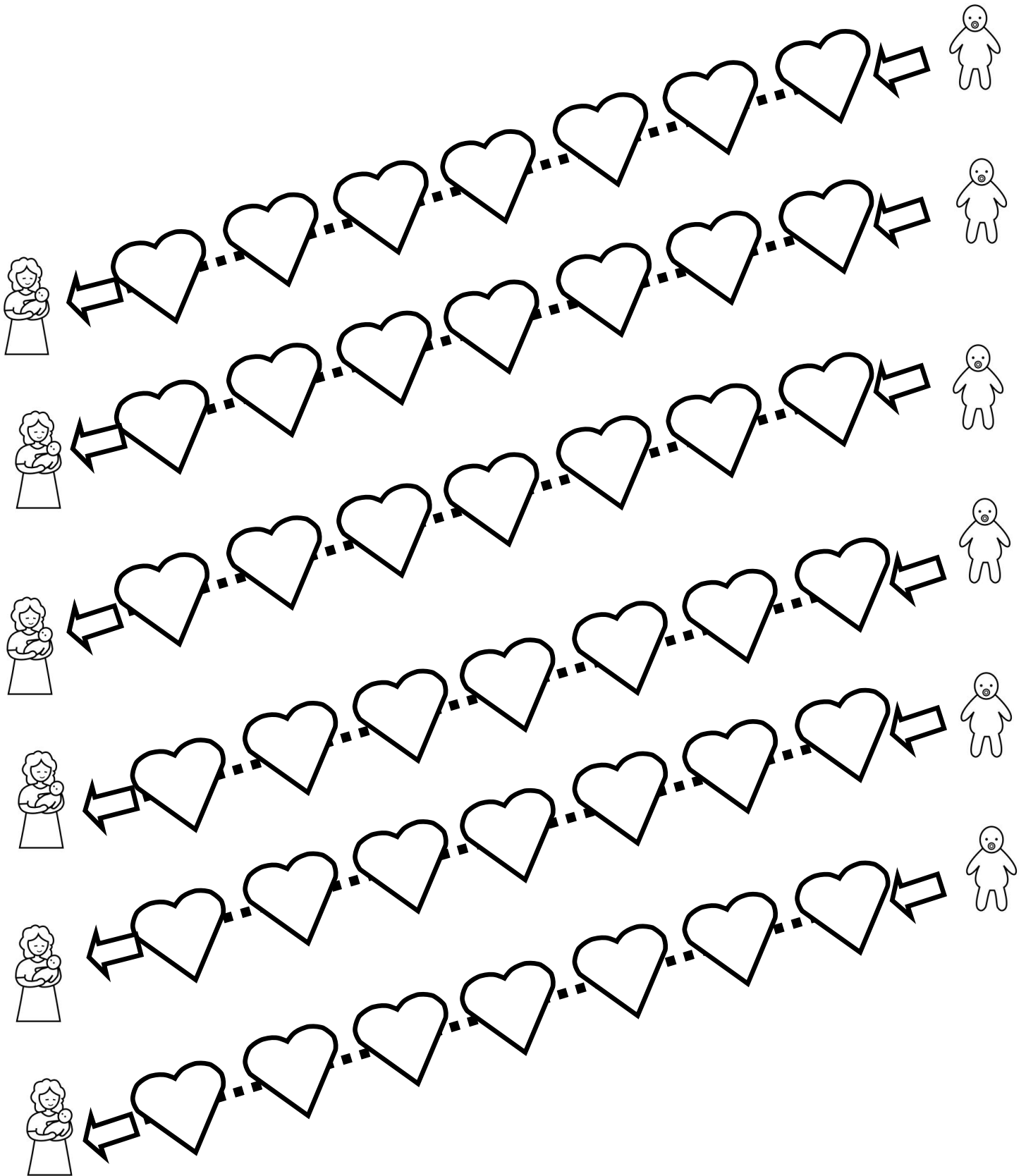

# Actividades para mejorar motricidad fina

Sigue con tu lápiz los corazones para unir a la mama y a su bebe

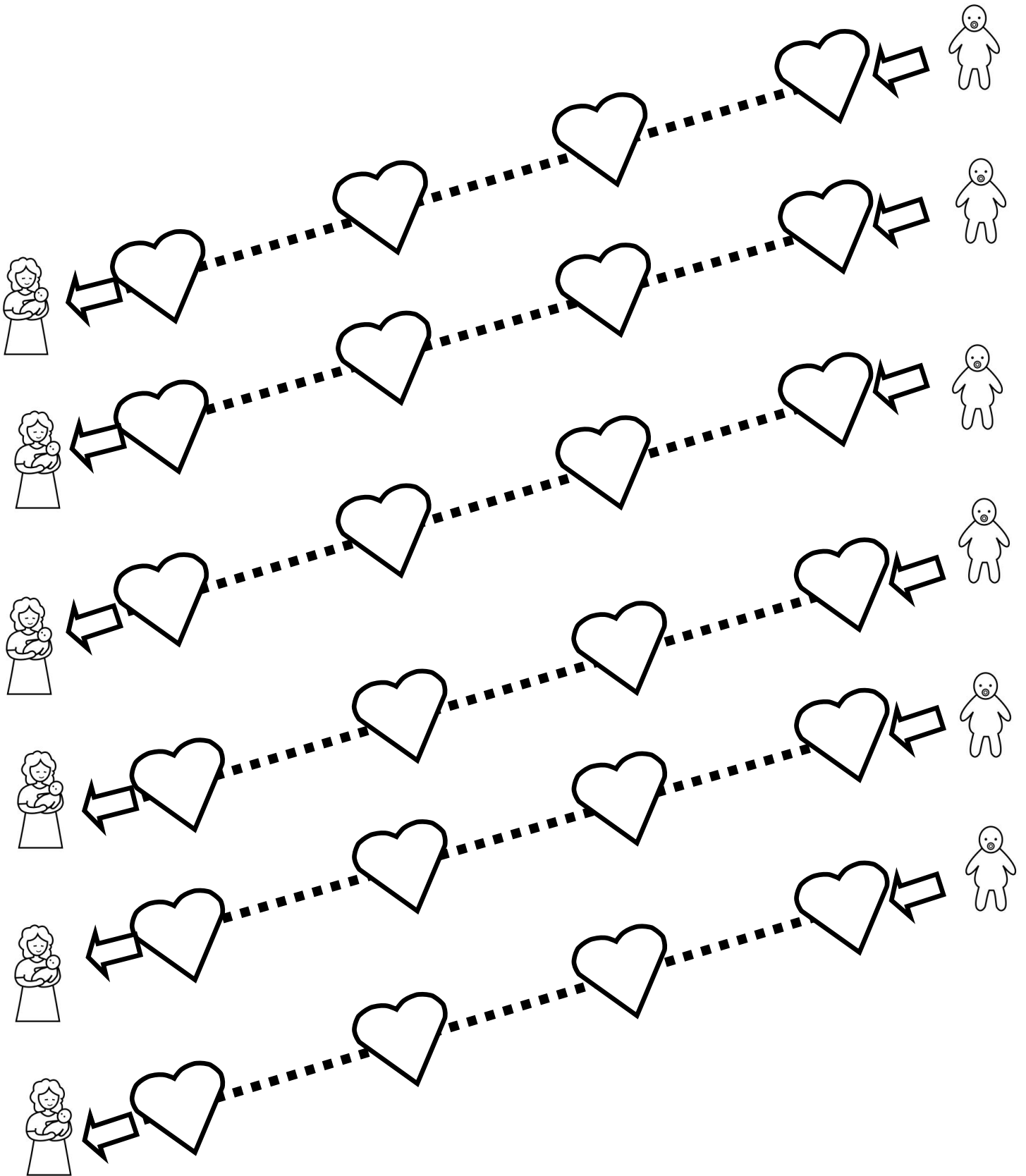

# Actividades para mejorar motricidad fina

Sigue con tu lápiz los corazones para unir a la mama y a su bebe

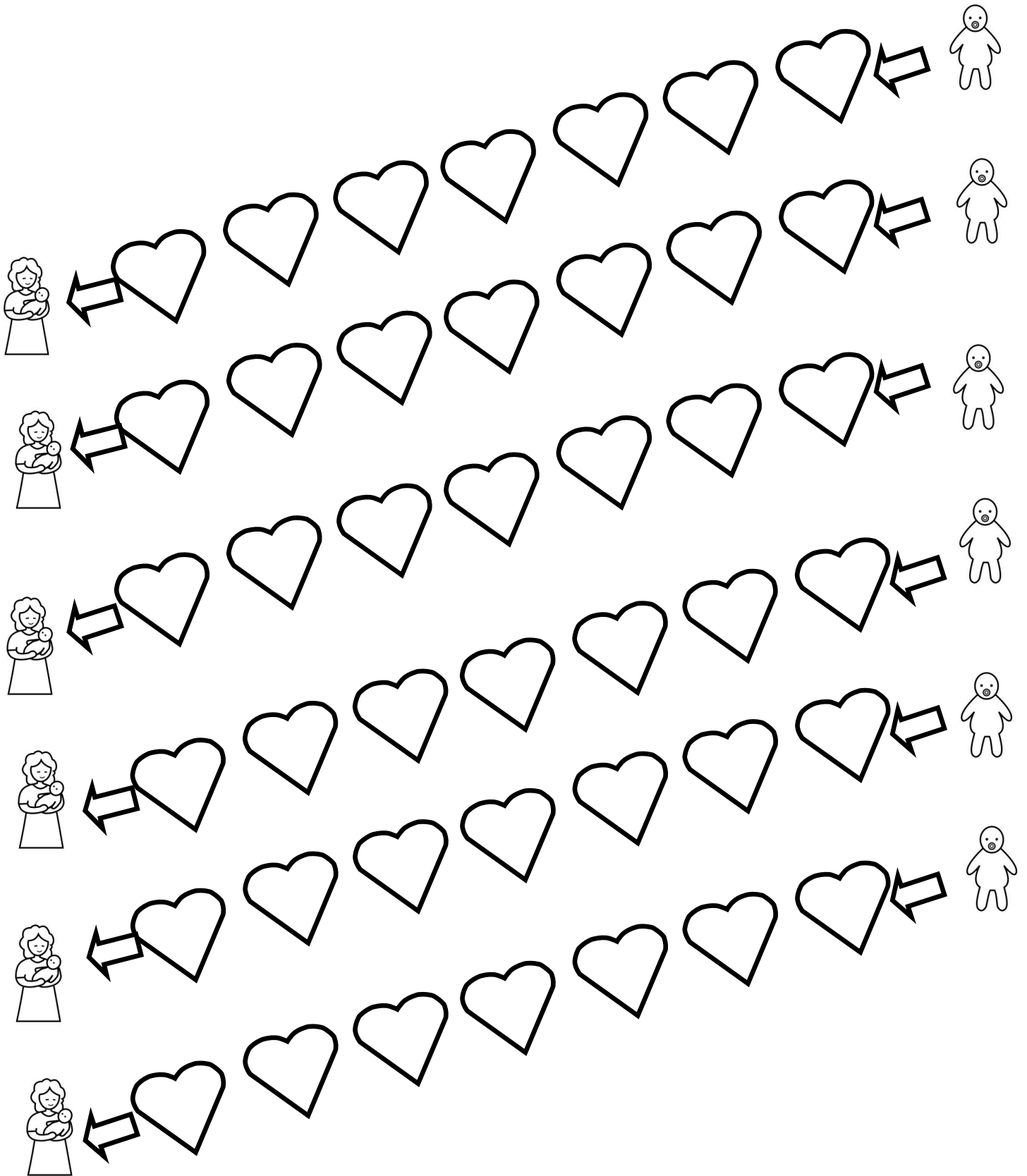

# Actividades para mejorar motricidad fina

Sigue con tu lápiz los corazones para unir a la mama y a su bebe

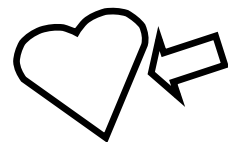
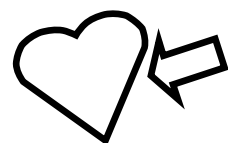
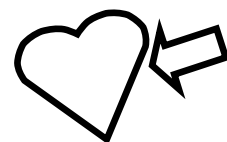
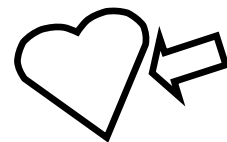
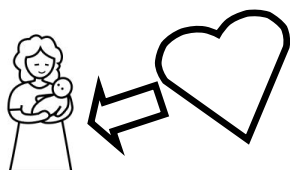
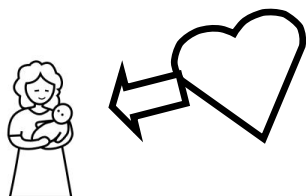
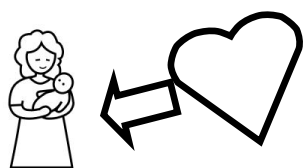
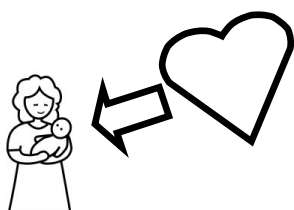
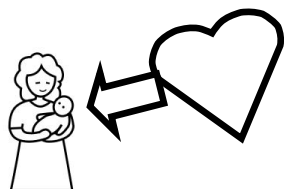
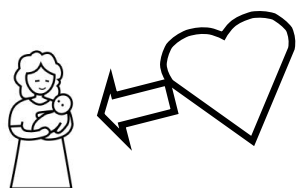

# Actividades para mejorar motricidad fina

Sigue con tu lápiz las caras para unir al niño con su amiga

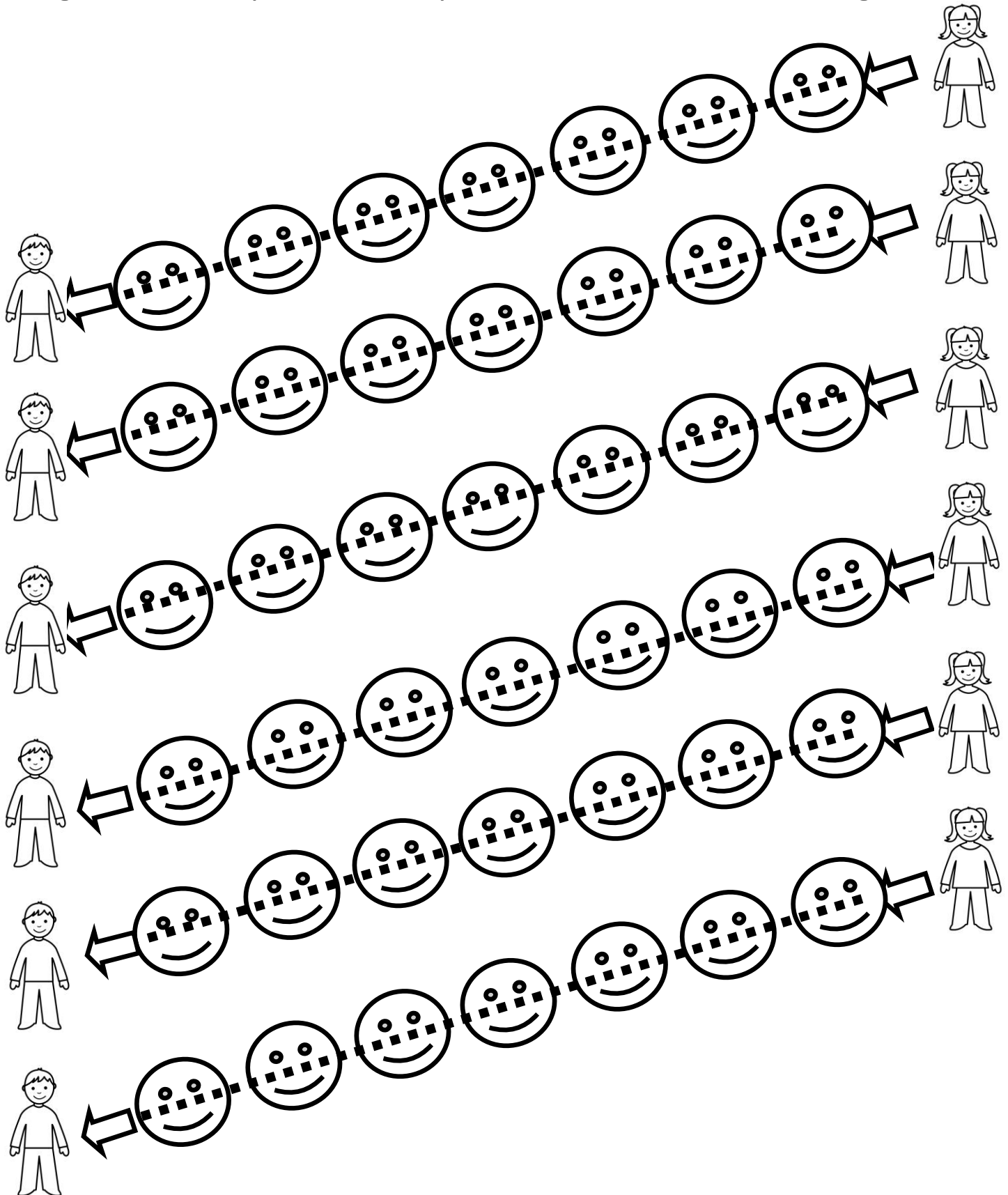



# Actividades para mejorar motricidad fina

Sigue con tu lápiz las caras para unir al niño con su amiga

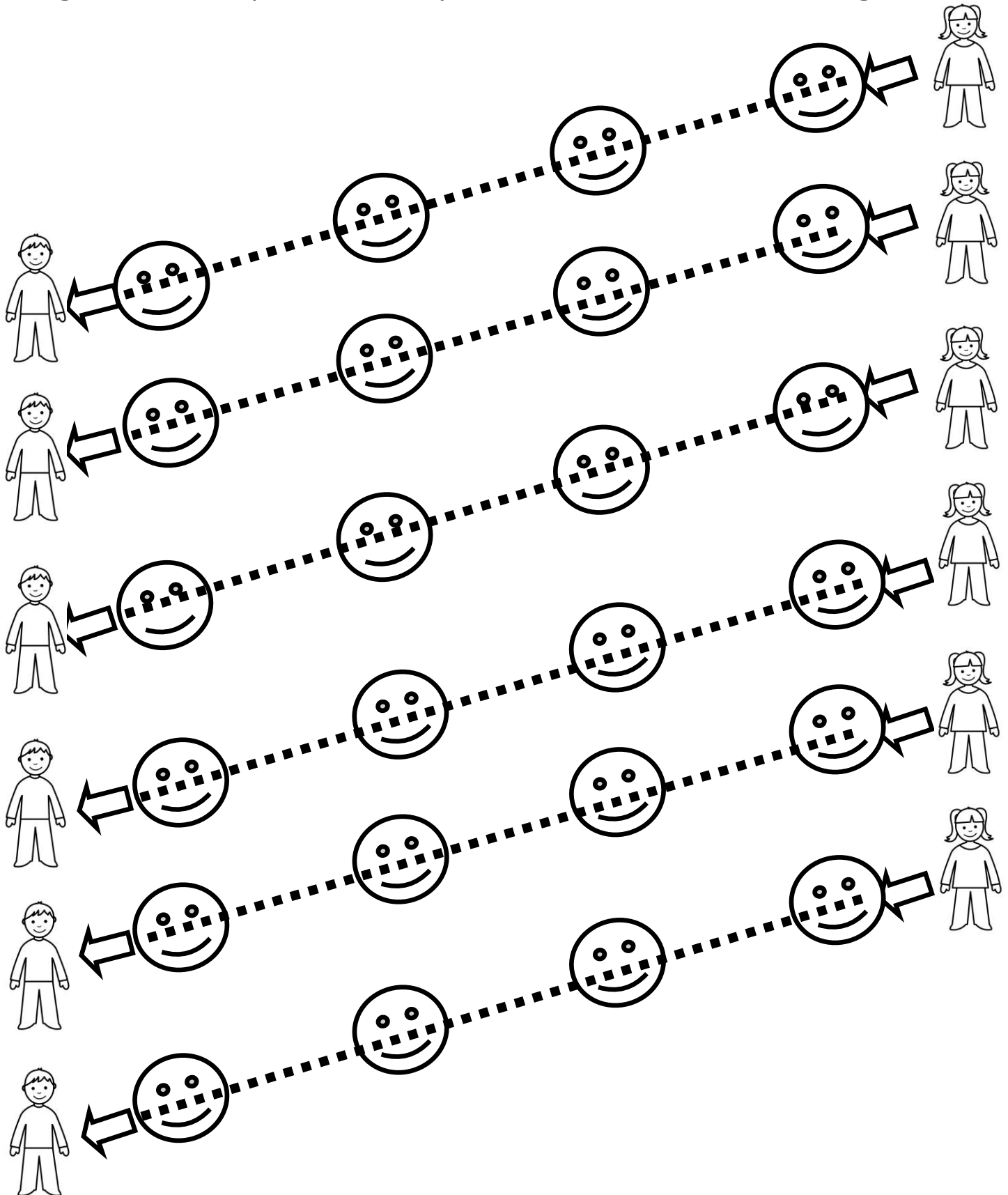

# Actividades para mejorar motricidad fina

Sigue con tu lápiz las caras para unir al niño con su amiga

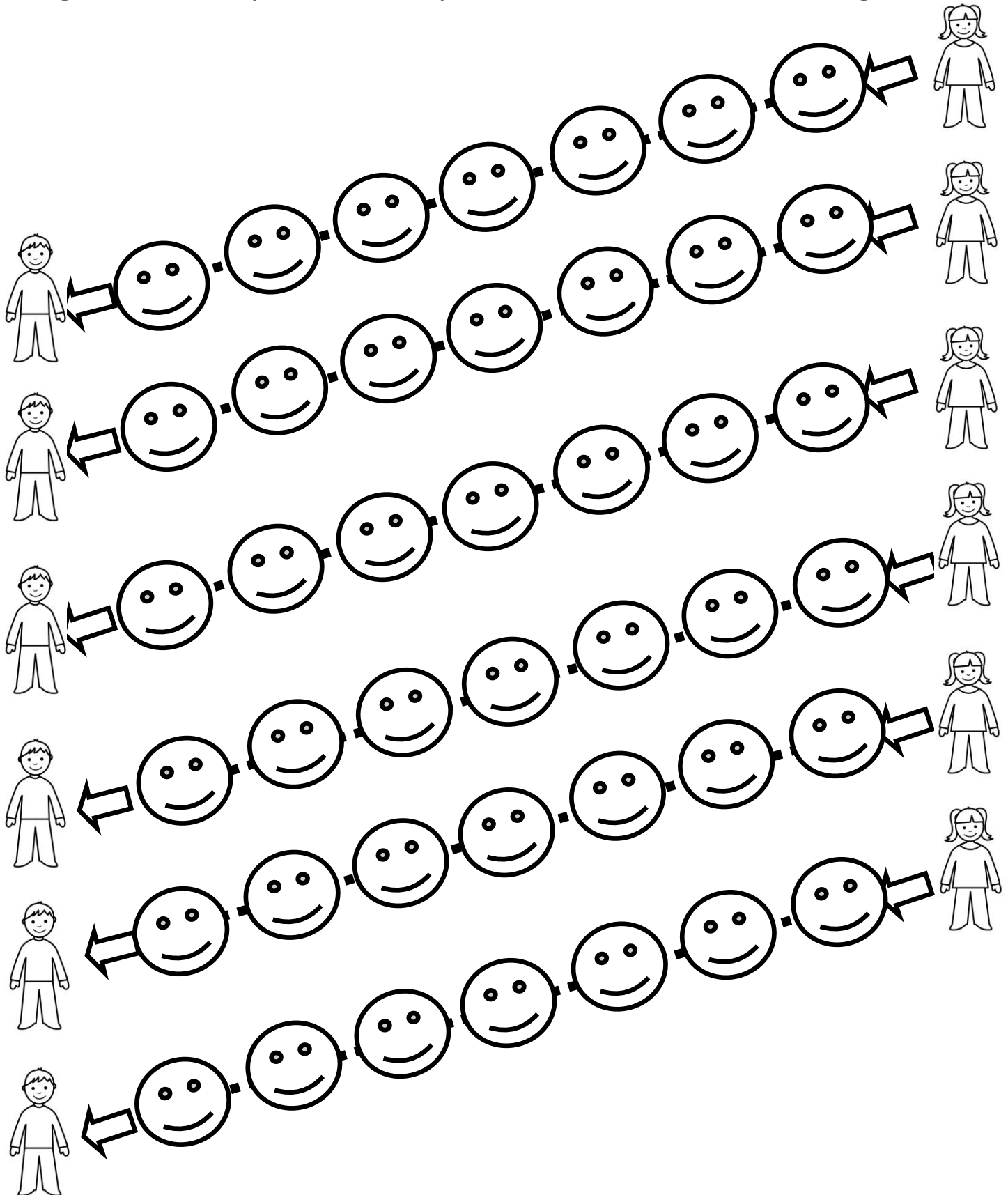

# Actividades para mejorar motricidad fina

Sigue con tu lápiz las caras para unir al niño con su amiga

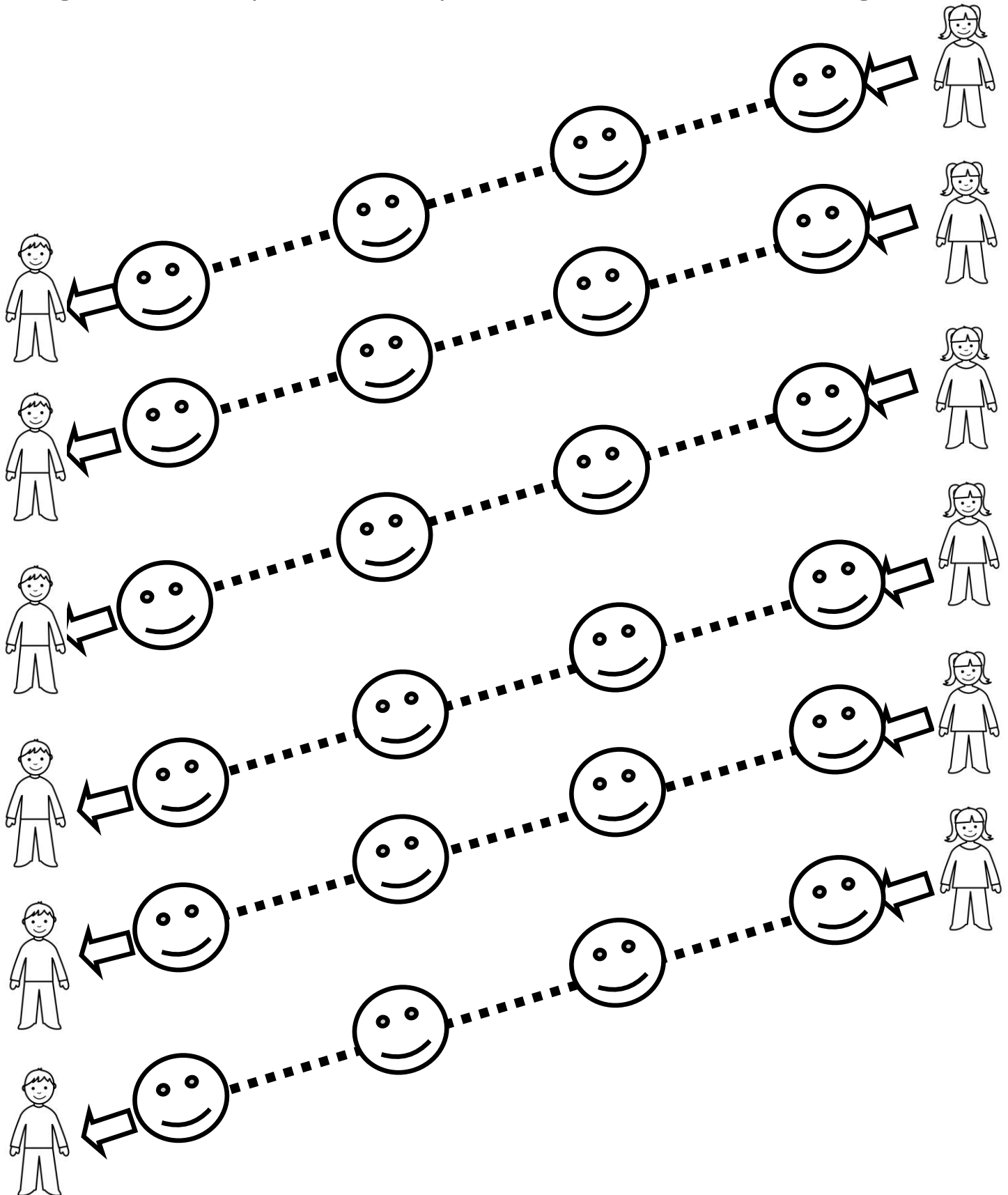

# Actividades para mejorar motricidad fina

Sigue con tu lápiz las caras para unir al niño con su amiga

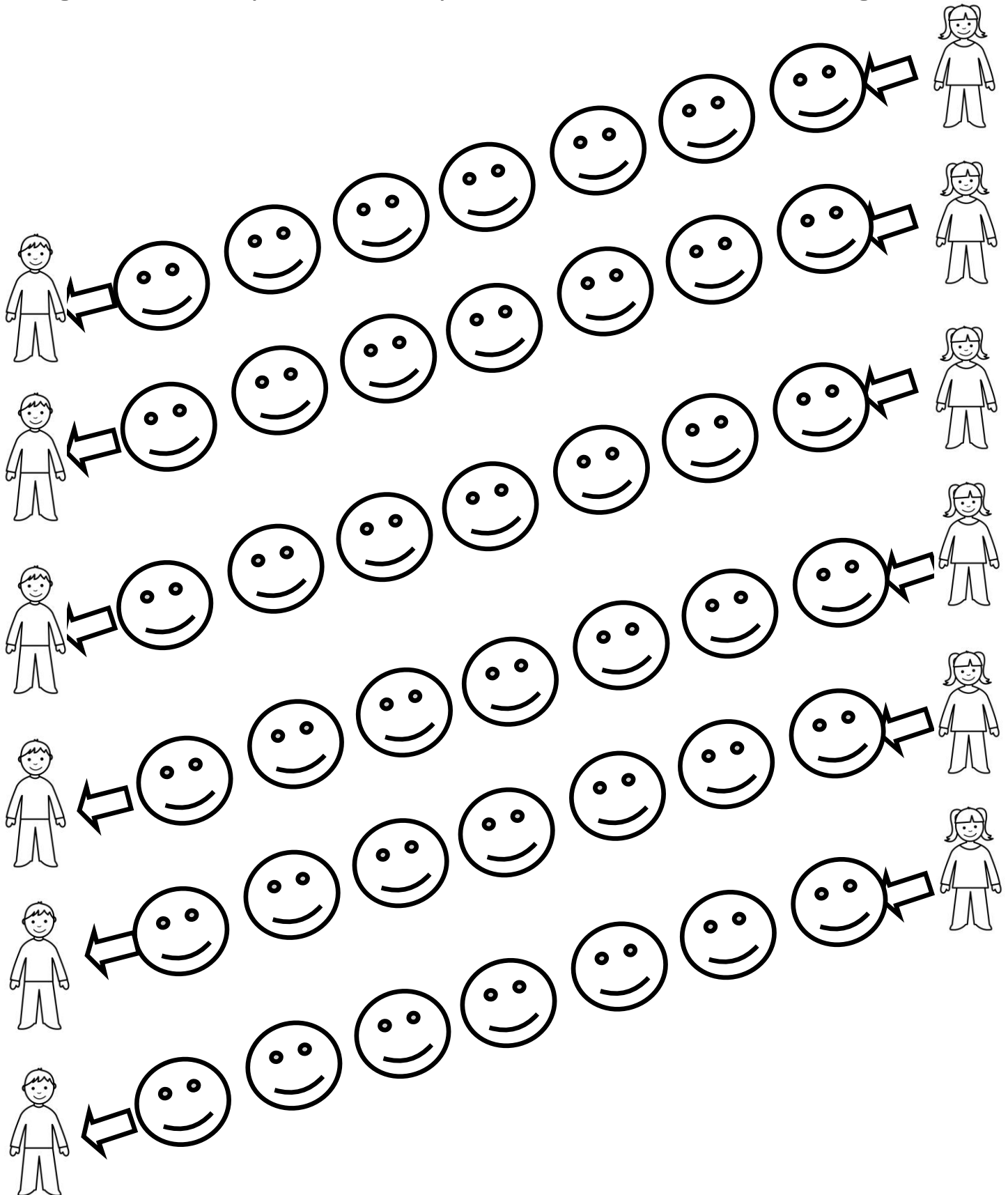

# Actividades para mejorar motricidad fina

Sigue con tu lápiz las caras para unir al niño con su amiga

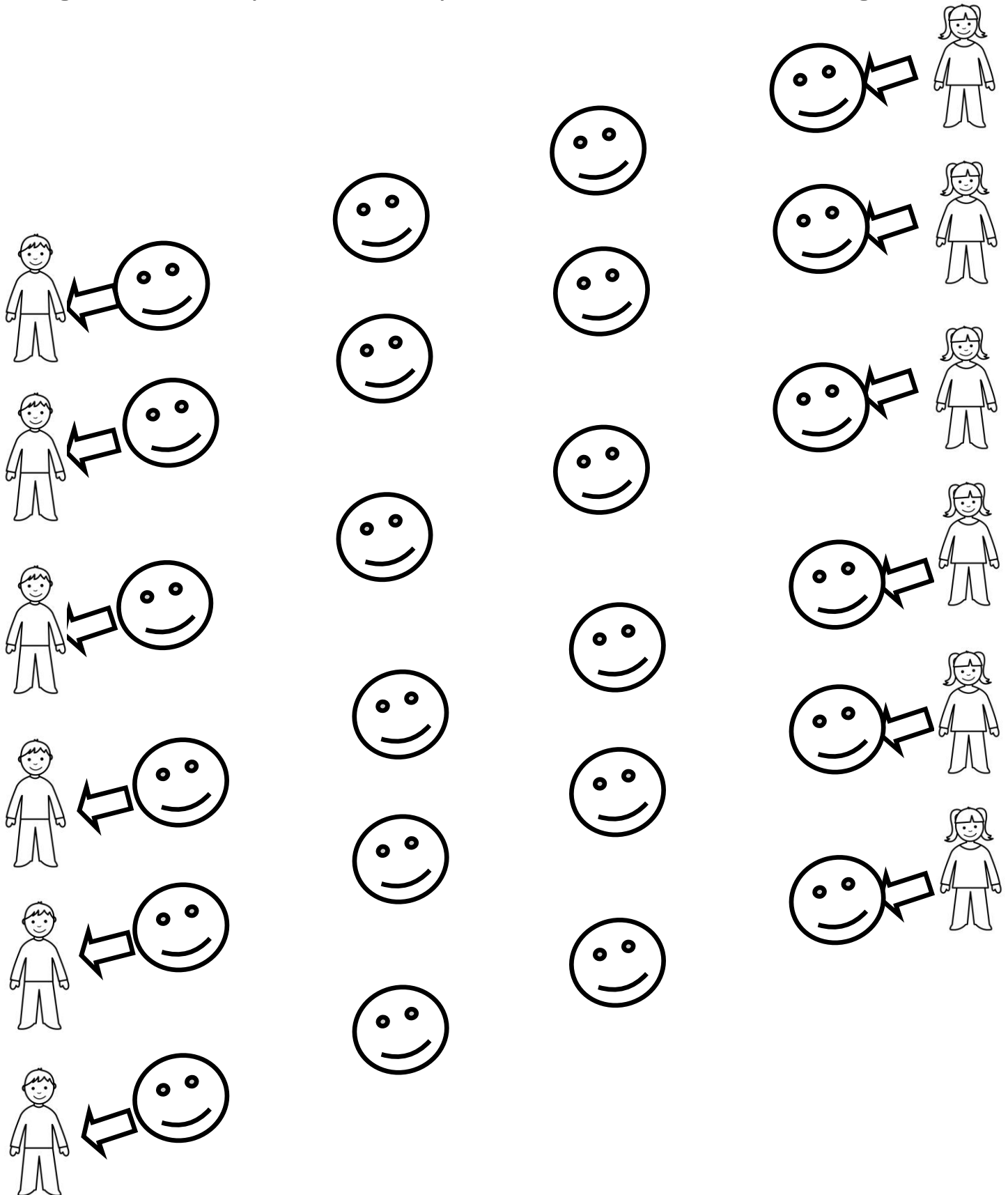

# Actividades para mejorar motricidad fina

Sigue con tu lápiz los círculos para unir al niño con su pelota

The worksheet contains seven identical rows. Each row consists of a zig-zag path of circles connected by a dashed line. The path starts on the left with a ball icon and ends on the right with a boy icon. The circles are arranged in a series of four peaks and three valleys, creating a continuous path from the ball to the boy. The instruction at the top asks the user to follow the circles with a pencil to connect the boy to his ball.

# Actividades para mejorar motricidad fina

Sigue con tu lápiz los círculos para unir al niño con su pelota

The worksheet contains seven rows of tracing exercises. Each row consists of a dashed line connecting a ball icon on the left to a boy icon on the right. The path includes four circles. An arrow on the rightmost circle indicates the direction towards the boy. The rows are arranged in a zig-zag pattern: the first row is high and slanted down to the left, the second is lower and slanted down to the right, and so on.

# Actividades para mejorar motricidad fina

Sigue con tu lápiz los círculos para unir al niño con su pelota

The worksheet contains seven identical rows of tracing practice. Each row consists of a ball icon on the left, a path of seven circles connected by small dashes, and a boy icon on the right. The path starts with a circle that has a thick arrow pointing left towards the ball, and ends with a circle that has a thick arrow pointing right towards the boy. The circles are arranged in a slightly curved line that moves from left to right across the rows.



# Actividades para mejorar motricidad fina

Sigue con tu lápiz los círculos para unir al niño con su pelota

The worksheet contains seven rows of tracing paths. Each row is designed to connect a ball on the left to a boy on the right. The path for each row is as follows: a solid circle with an arrow pointing left, followed by a dotted line connecting three more solid circles, and finally a solid circle with an arrow pointing right.

# Actividades para mejorar motricidad fina

Sigue con tu lápiz los círculos para unir al niño con su pelota

The worksheet contains seven identical rows. Each row begins on the left with a ball icon and an arrow pointing to the first of a series of circles. The path of circles curves and zig-zags across the page. Each row ends on the right with a boy icon and an arrow pointing to the final circle. The goal is to trace the path of circles with a pencil.

# Actividades para mejorar motricidad fina

Sigue con tu lápiz los círculos para unir al niño con su pelota

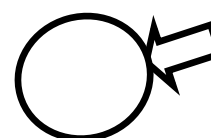
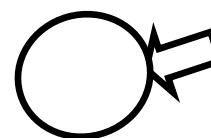
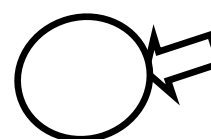
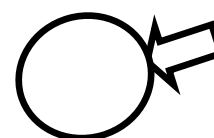
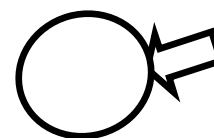
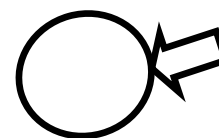
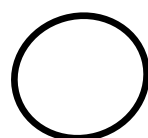
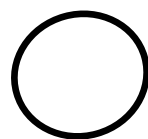
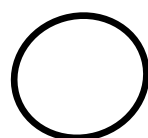
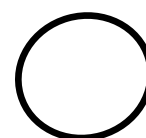
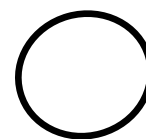
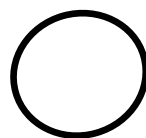
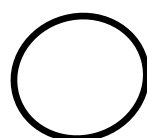
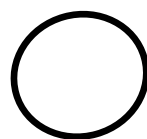
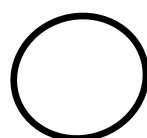
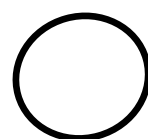
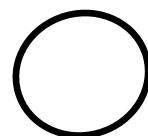
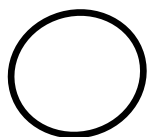
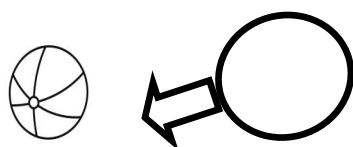
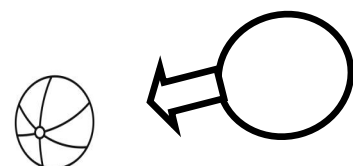
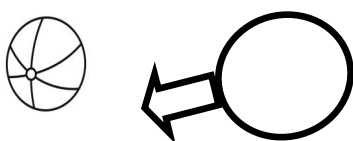
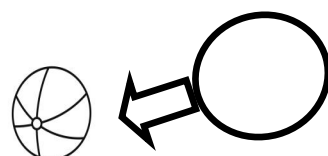
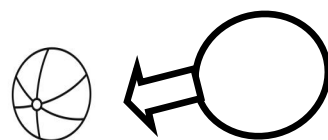
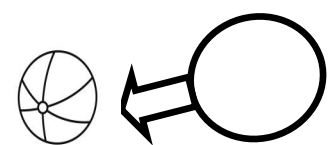

# Actividades para mejorar motricidad fina

Sigue con tu lápiz los cuadrados para unir a la niña con su casa

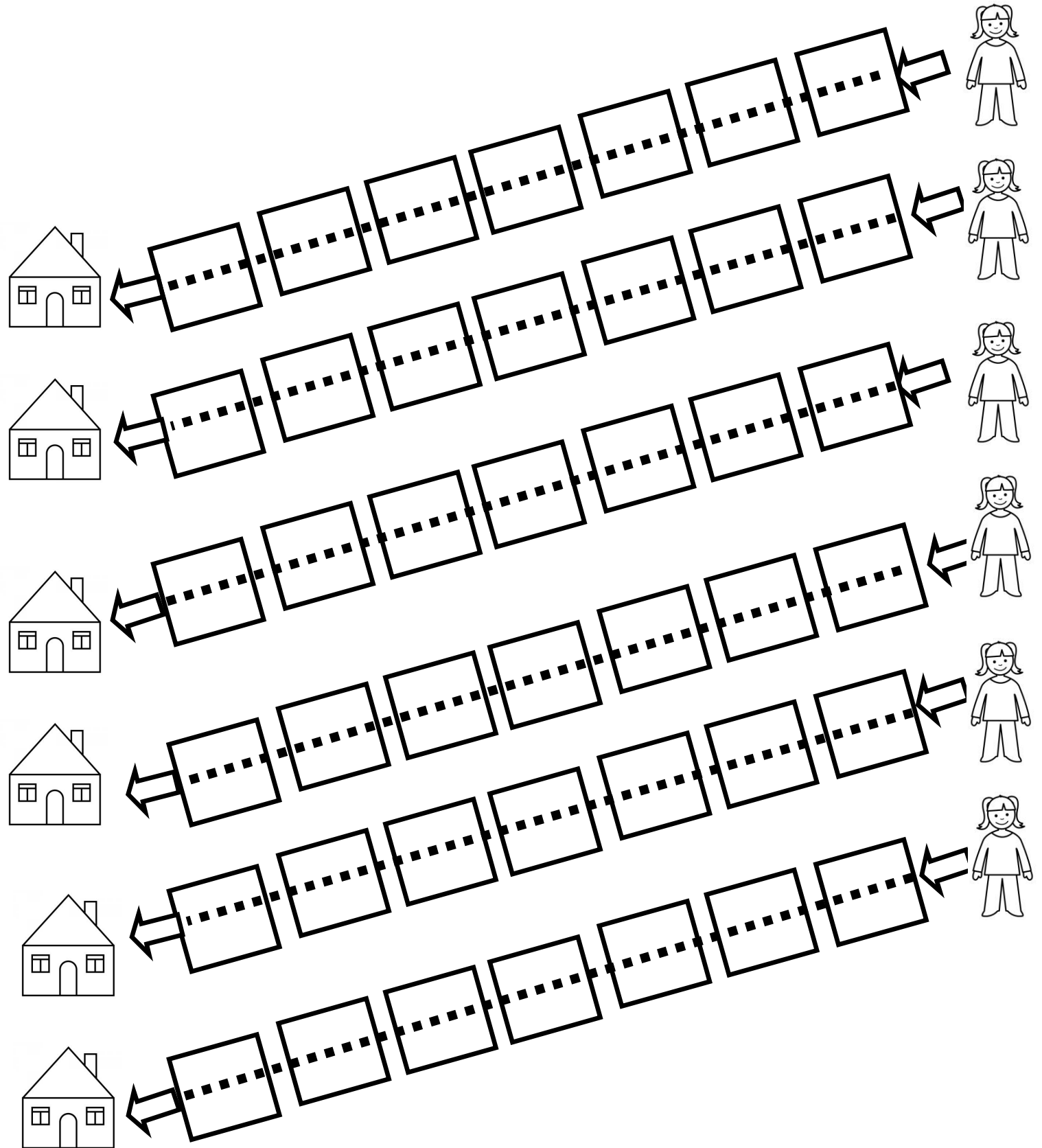

# Actividades para mejorar motricidad fina

Sigue con tu lápiz los cuadrados para unir a la niña con su casa

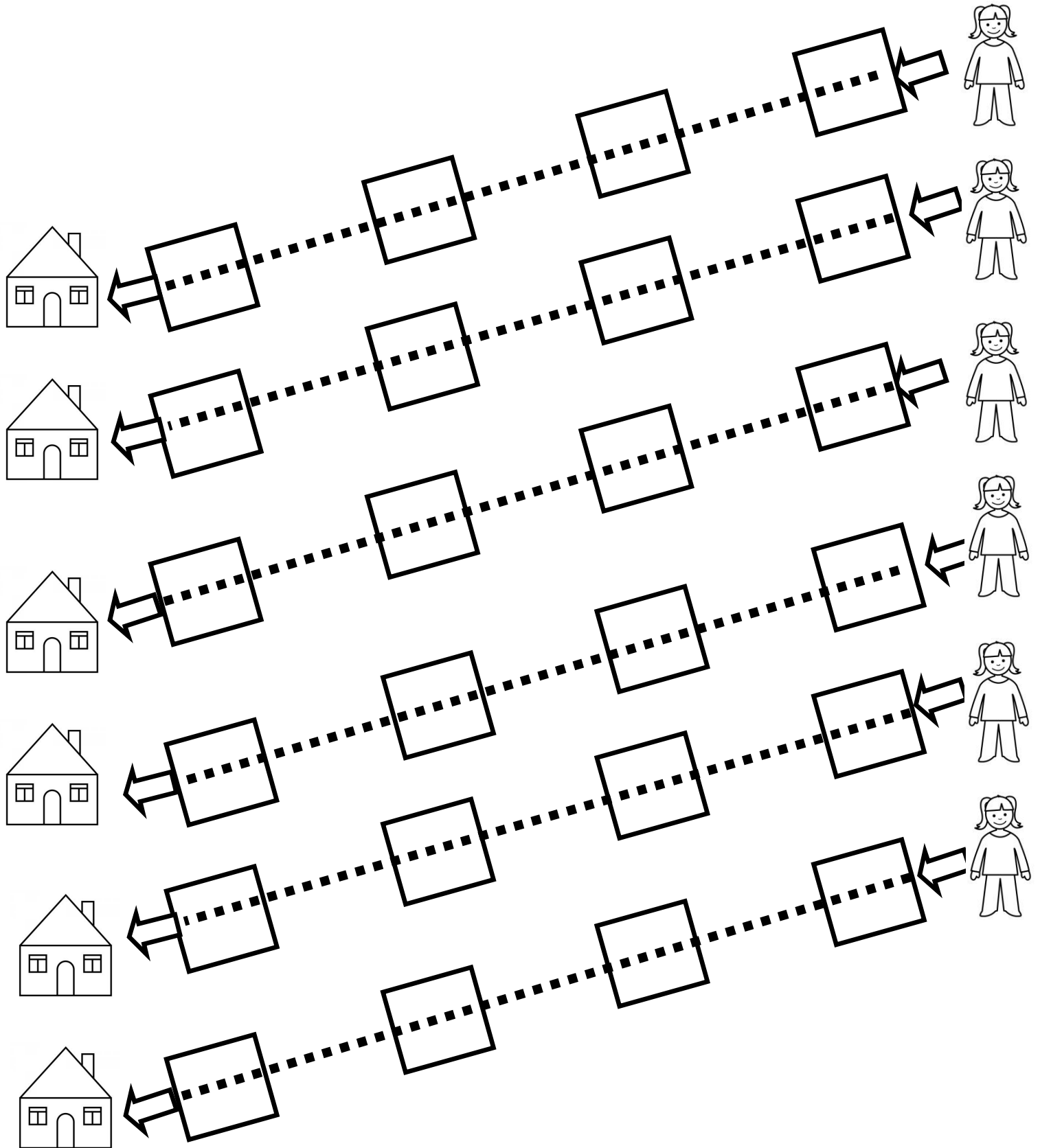

# Actividades para mejorar motricidad fina

Sigue con tu lápiz los cuadrados para unir a la niña con su casa

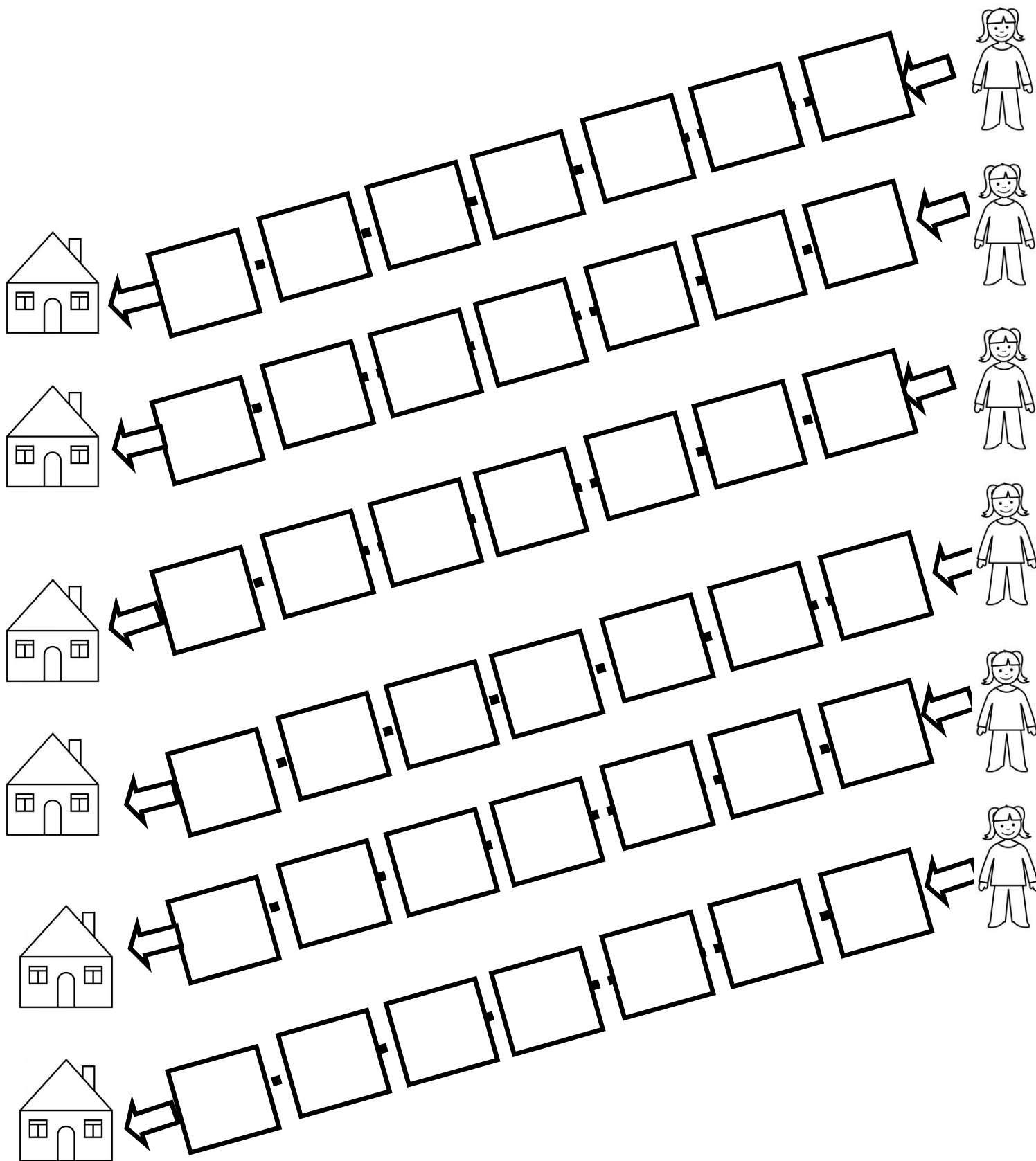

# Actividades para mejorar motricidad fina

Sigue con tu lápiz los cuadrados para unir a la niña con su casa

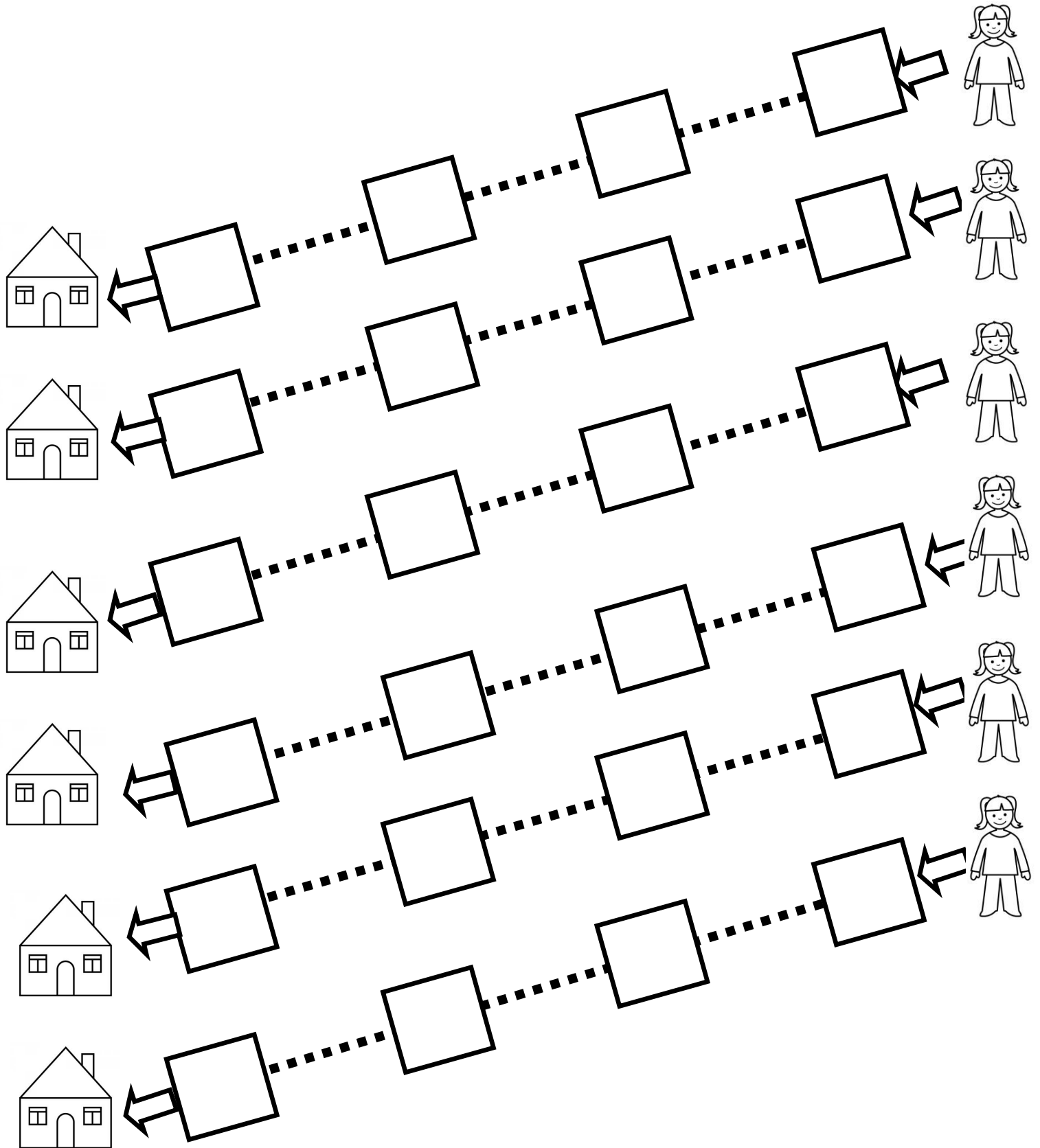

# Actividades para mejorar motricidad fina

Sigue con tu lápiz los cuadrados para unir a la niña con su casa

The worksheet contains six rows of tracing practice. Each row consists of a sequence of squares. On the left side of each row is a simple line drawing of a house with a chimney, two windows, and a door. On the right side of each row is a simple line drawing of a girl with pigtails, wearing a long-sleeved shirt and pants. A black arrow points from the girl icon to the first square in the row, indicating the starting point and direction of the tracing activity. The squares are arranged in a slightly descending diagonal pattern from top-left to bottom-right across the page.



# Actividades para mejorar motricidad fina

Sigue con tu lápiz los cuadrados para unir a la niña con su casa

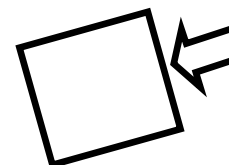
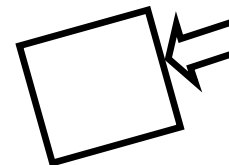
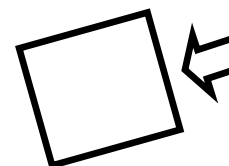
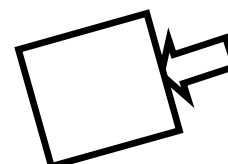
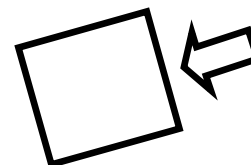
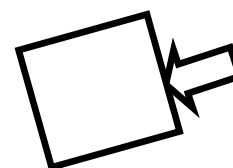
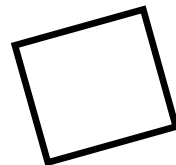
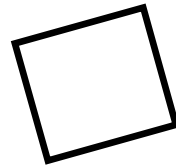
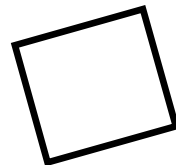
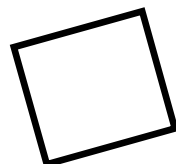
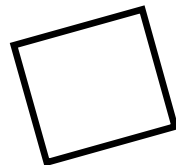
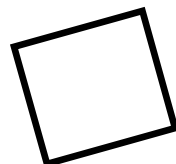
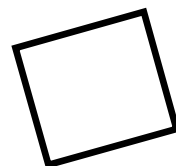
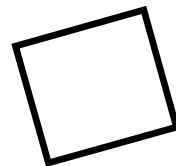
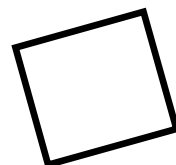
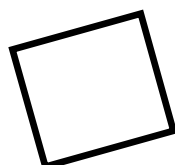
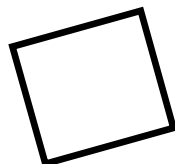
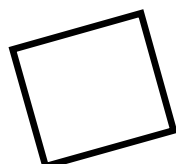
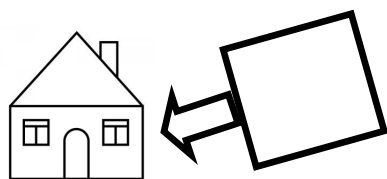
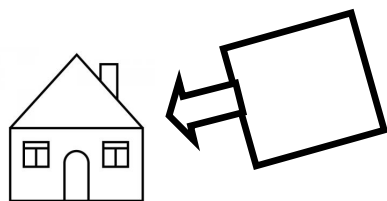
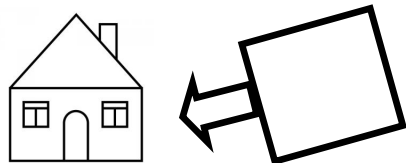
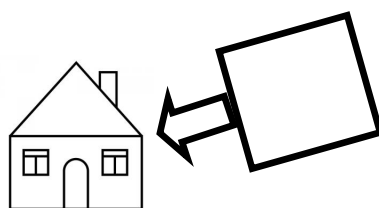
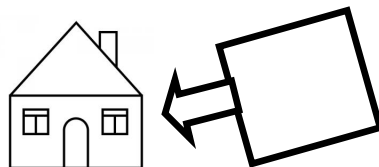
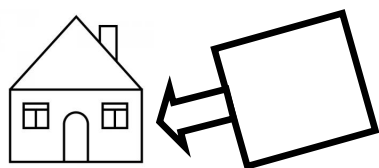

# Actividades para mejorar motricidad fina

Sigue con tu lápiz las estrellitas para ir desde el sol a la tierra

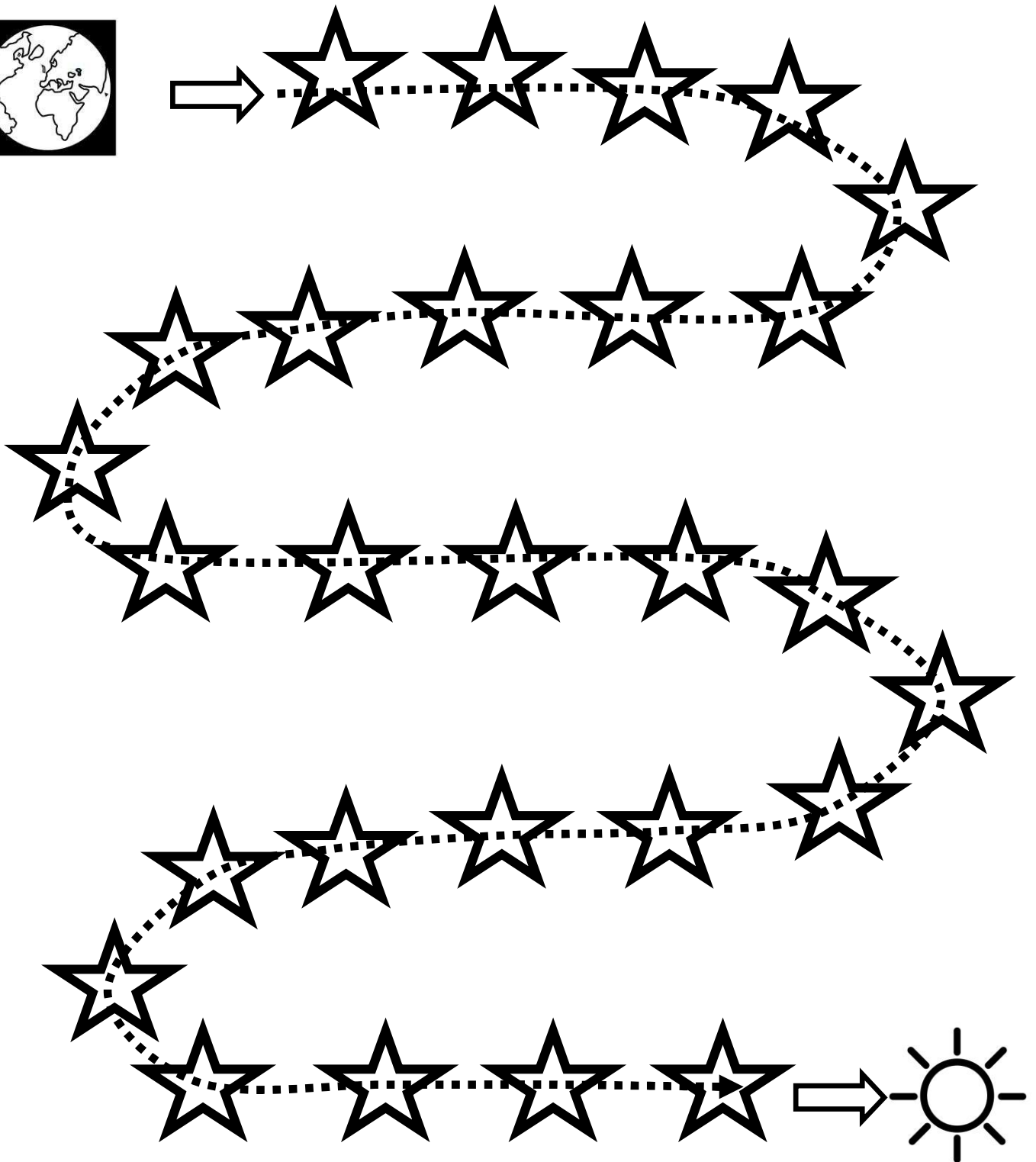

# Actividades para mejorar motricidad fina

Sigue con tu lápiz las estrellitas para ir desde el sol a la tierra

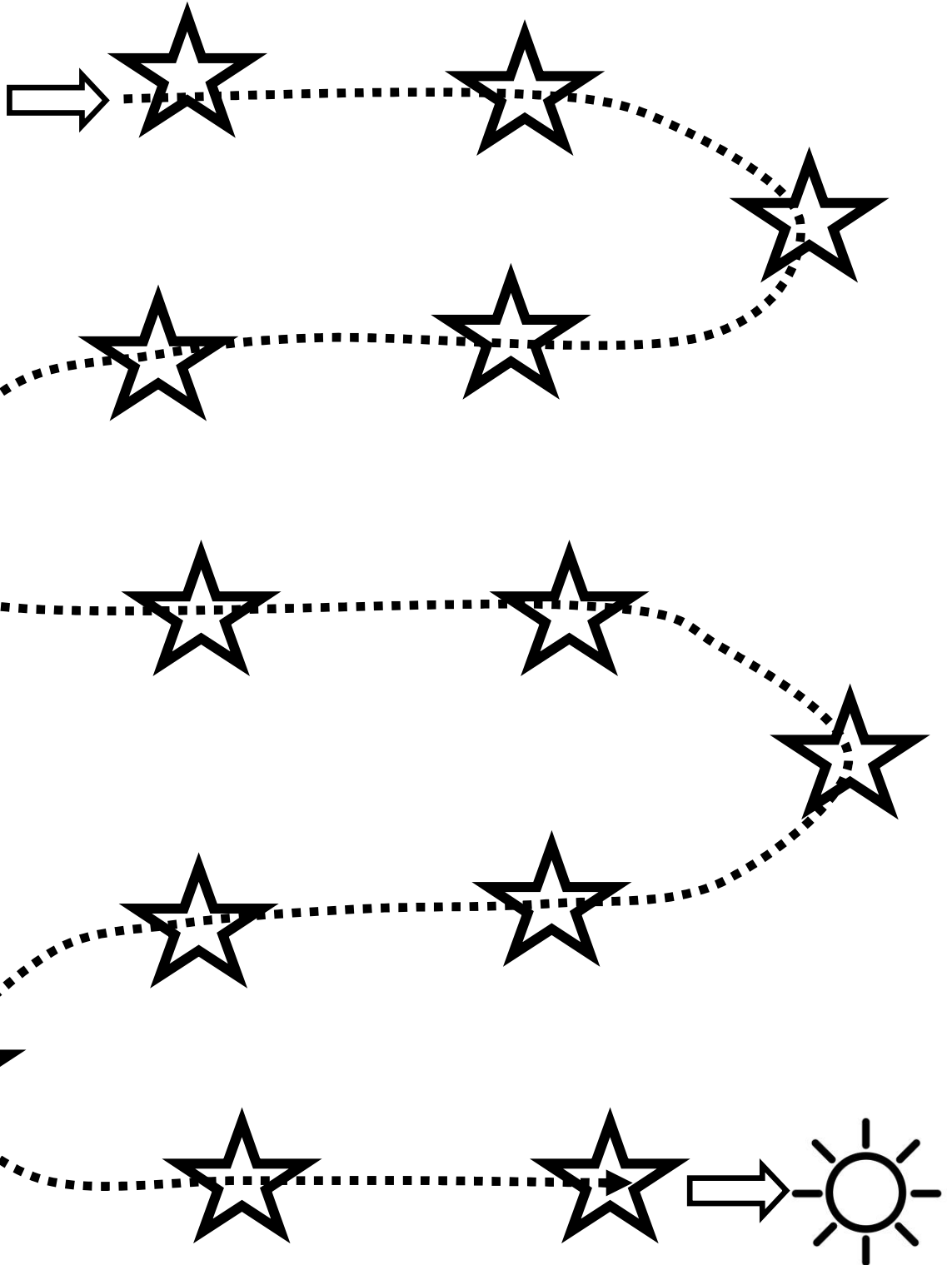

# Actividades para mejorar motricidad fina

Sigue con tu lápiz las estrellitas para ir desde el sol a la tierra

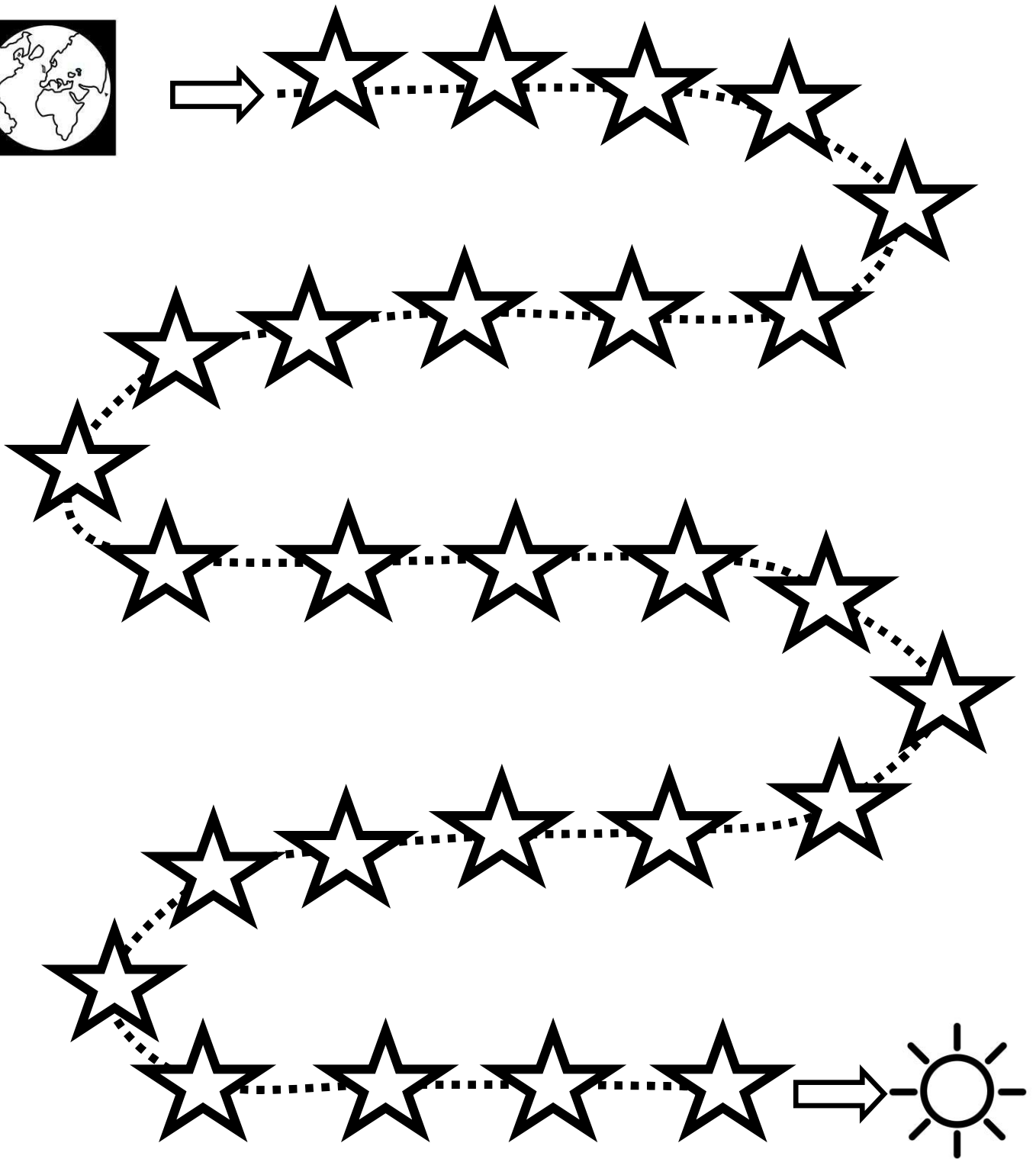

# Actividades para mejorar motricidad fina

Sigue con tu lápiz las estrellitas para ir desde el sol a la tierra

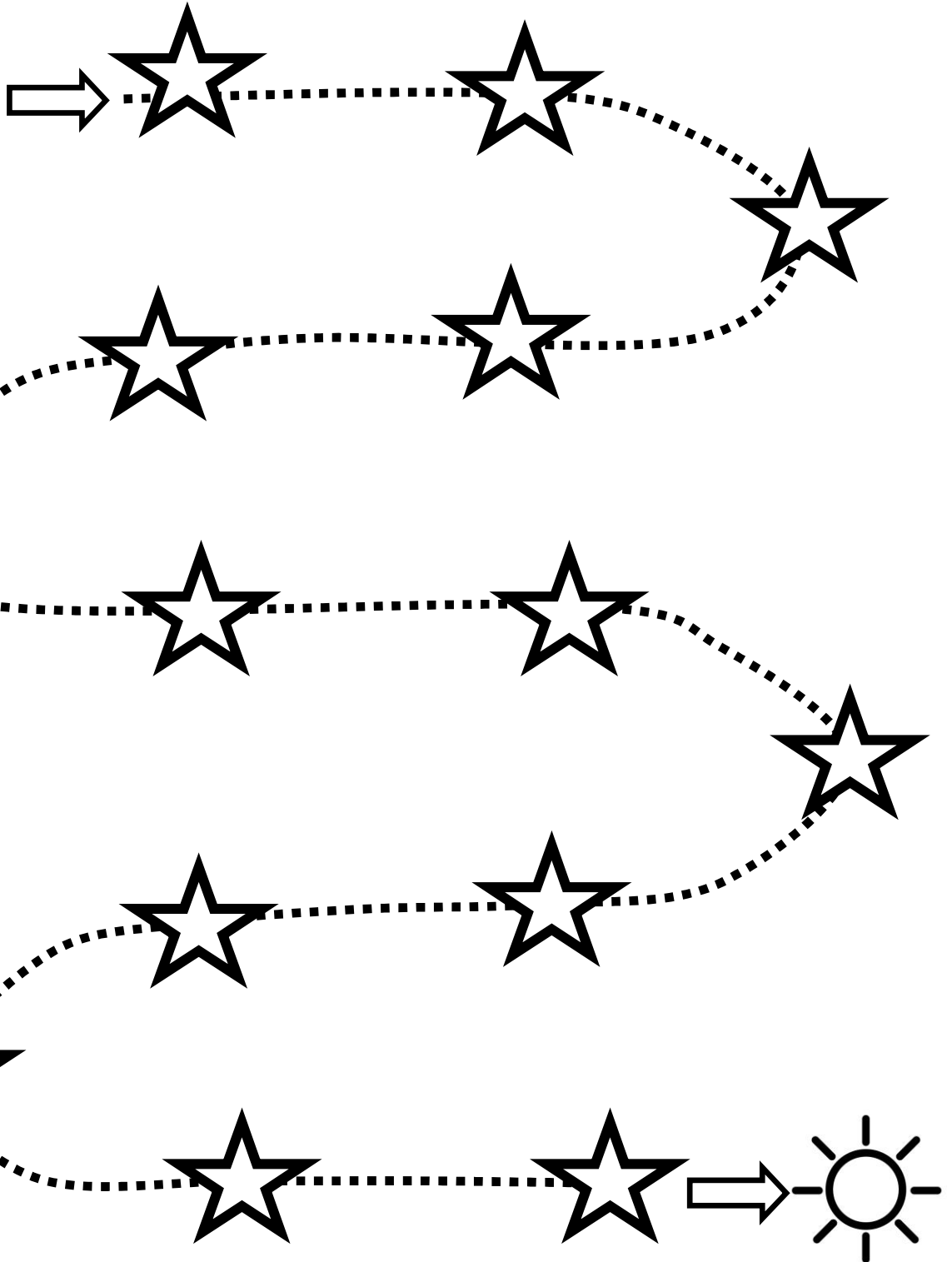

# Actividades para mejorar motricidad fina

Sigue con tu lápiz las estrellitas para ir desde el sol a la tierra



# Actividades para mejorar motricidad fina

Sigue con tu lápiz las estrellitas para ir desde el sol a la tierra

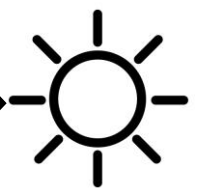
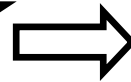
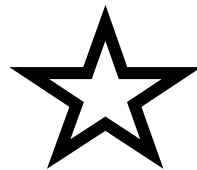
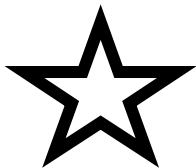
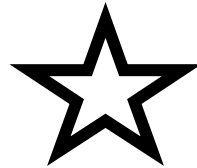
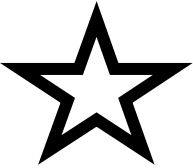

# Actividades para mejorar motricidad fina

Sigue con tu lápiz los corazones para unir a la mama y a su bebe

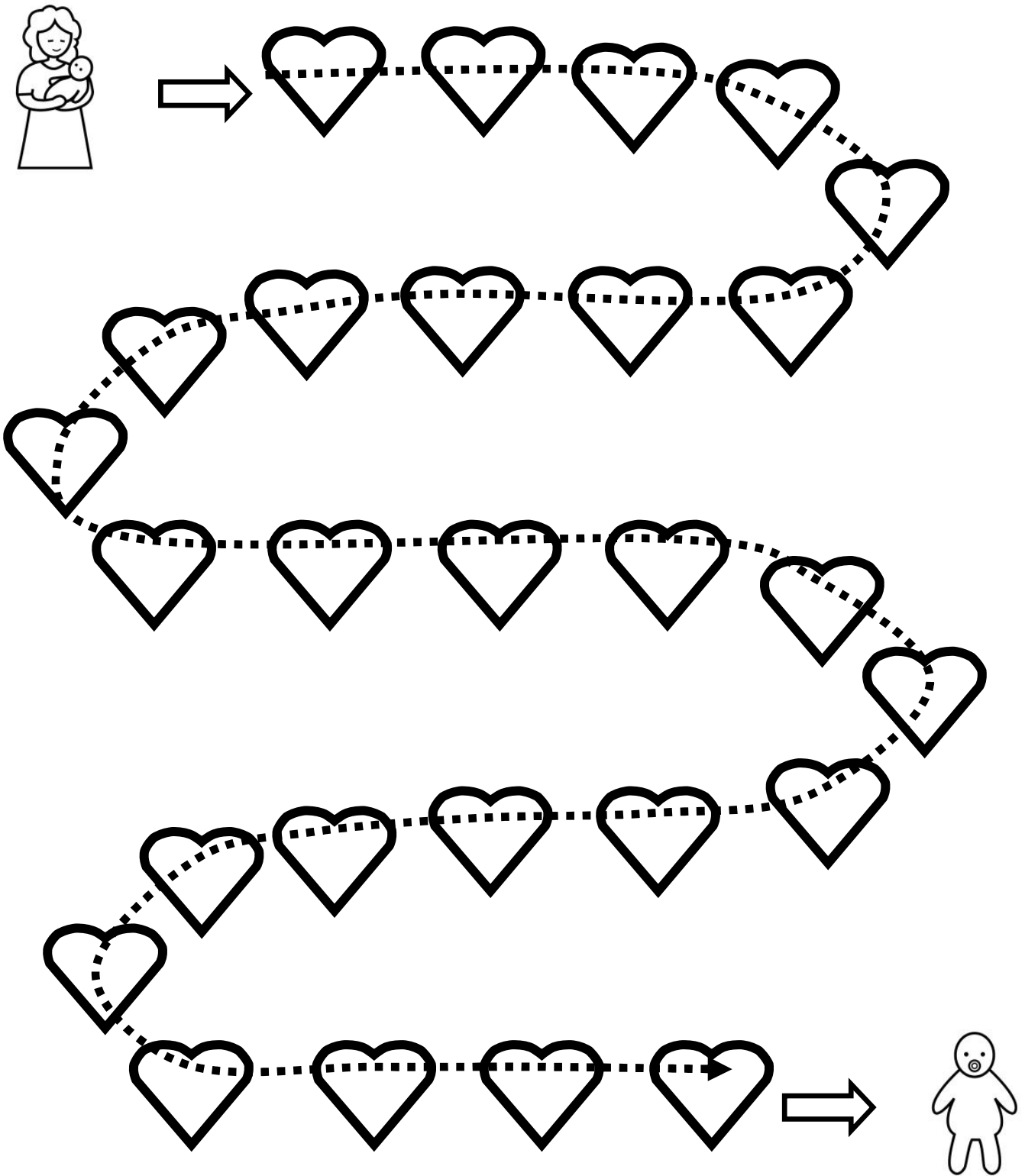



# Actividades para mejorar motricidad fina

Sigue con tu lápiz los corazones para unir a la mama y a su bebe

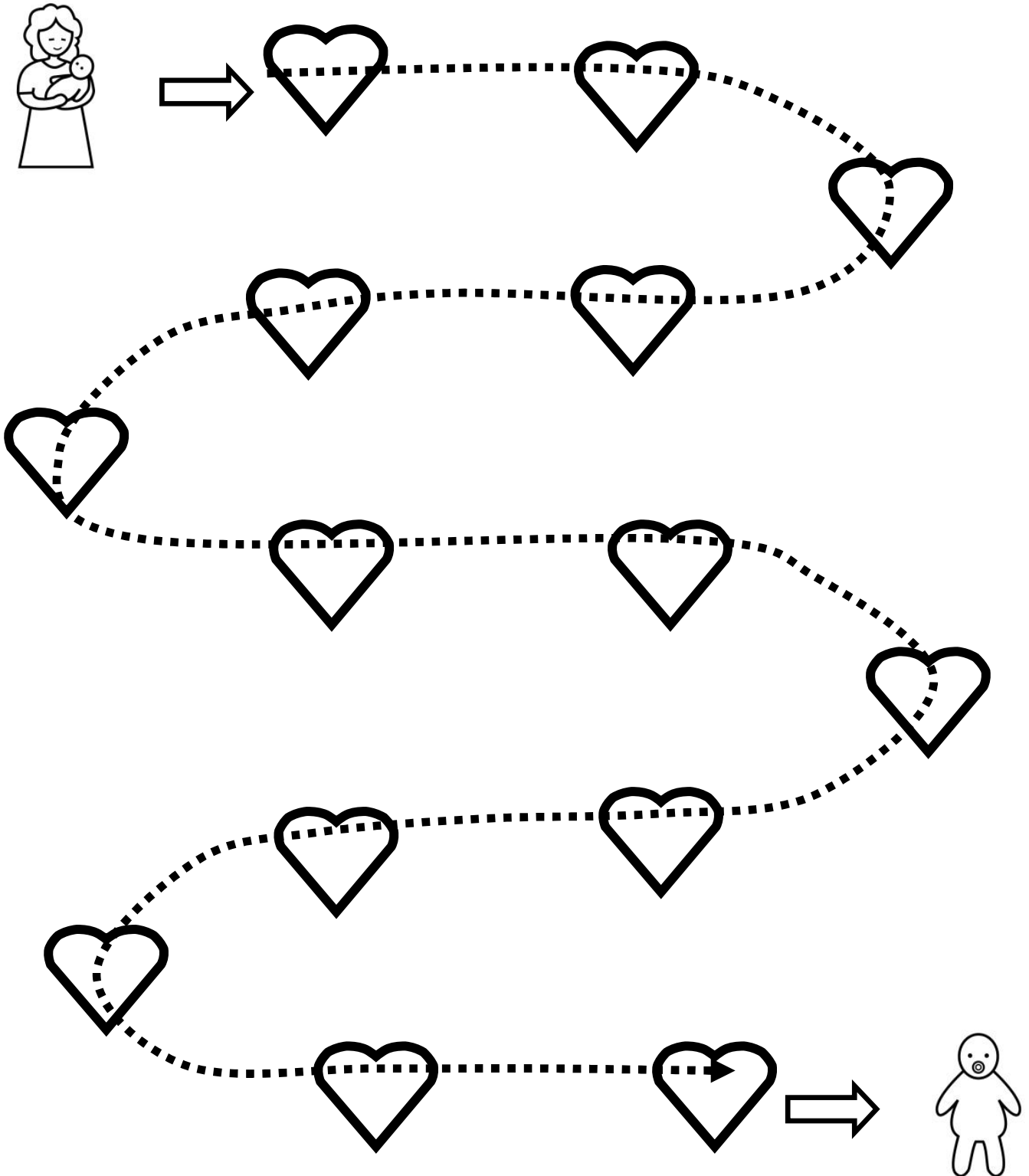

# Actividades para mejorar motricidad fina

Sigue con tu lápiz los corazones para unir a la mama y a su bebe

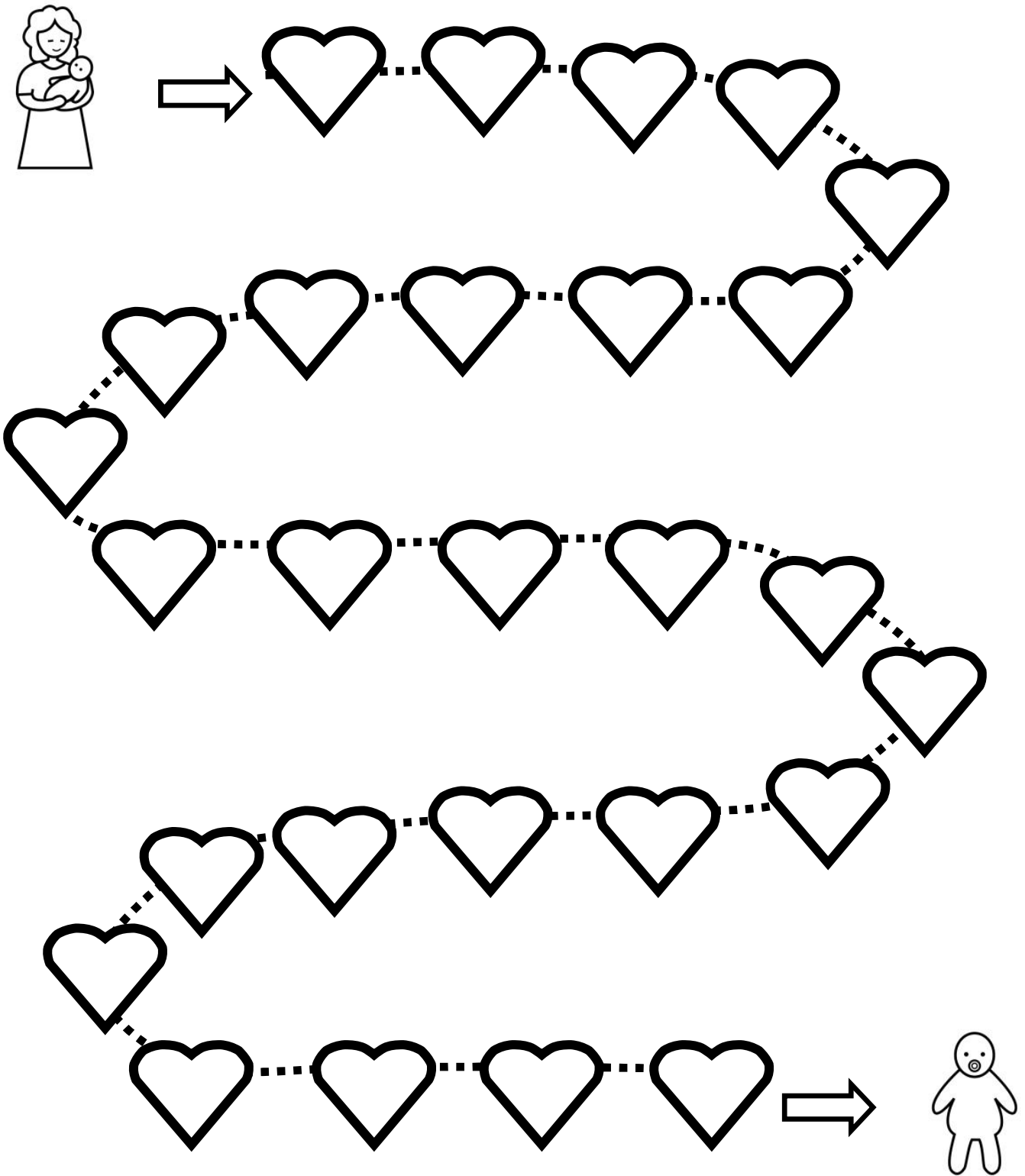

## Actividades para mejorar motricidad fina

Sigue con tu lápiz los corazones para unir a la mama y a su bebe

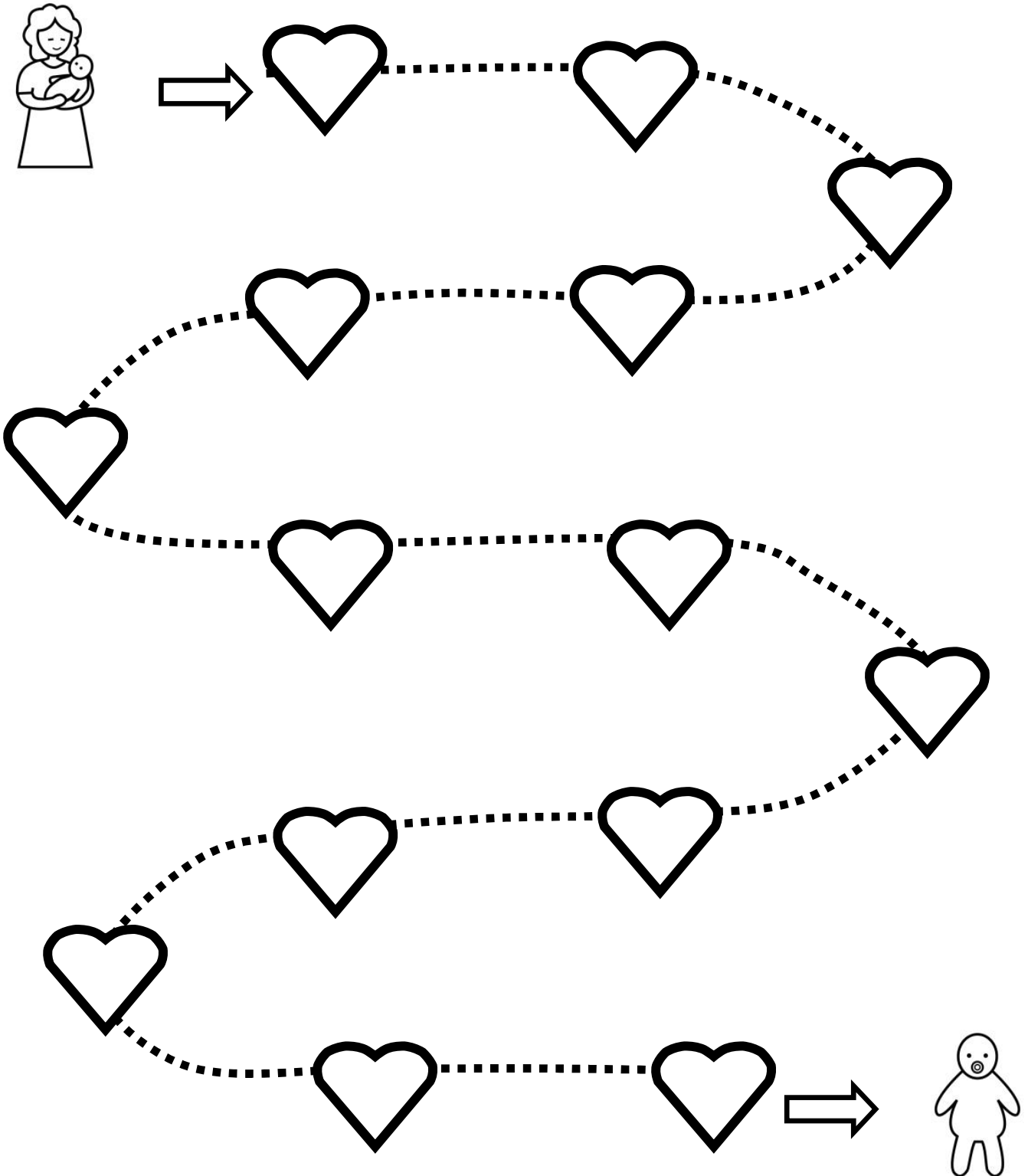

## Actividades para mejorar motricidad fina

Sigue con tu lápiz los corazones para unir a la mama y a su bebe

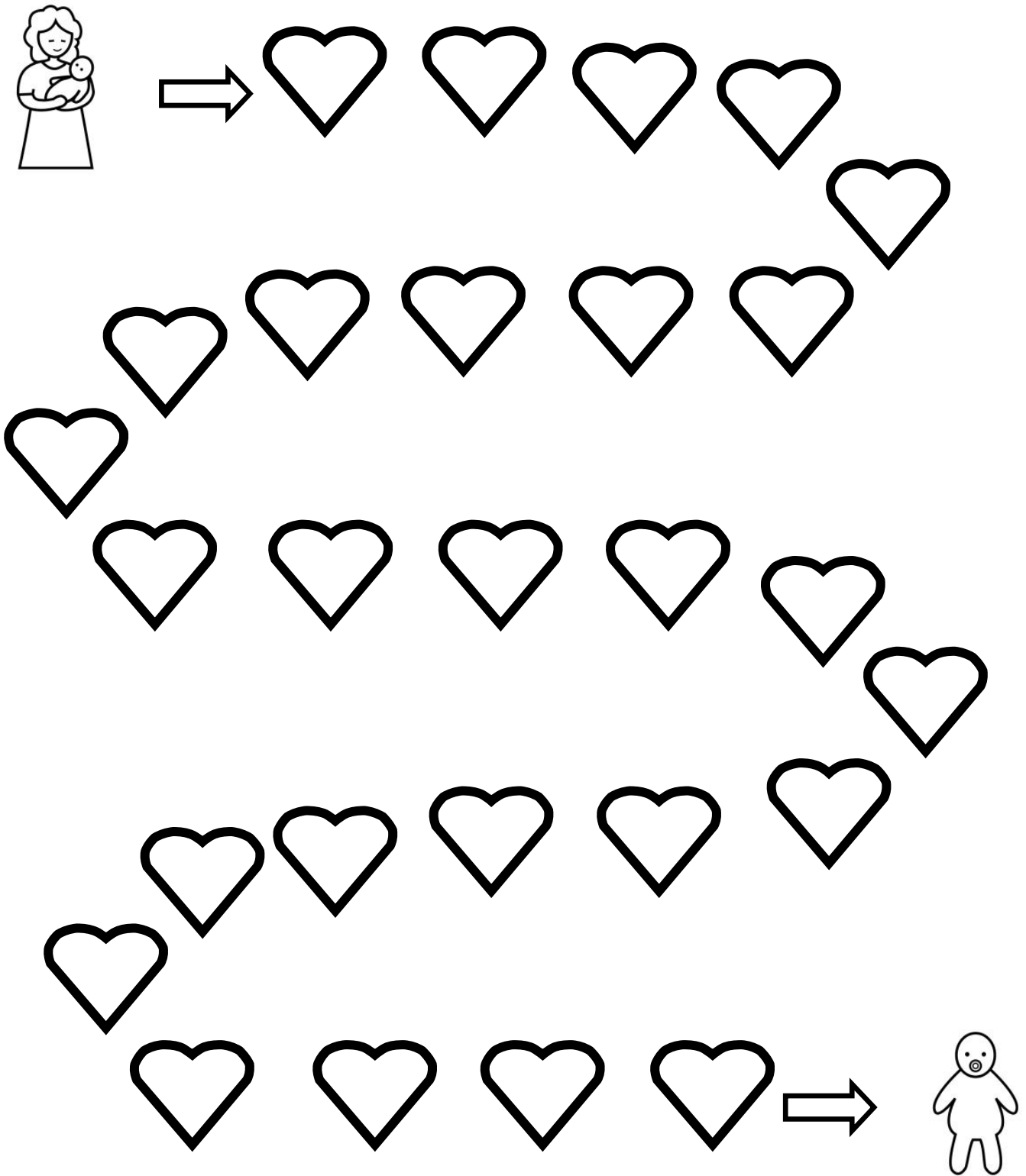

## Actividades para mejorar motricidad fina

Sigue con tu lápiz los corazones para unir a la mama y a su bebe

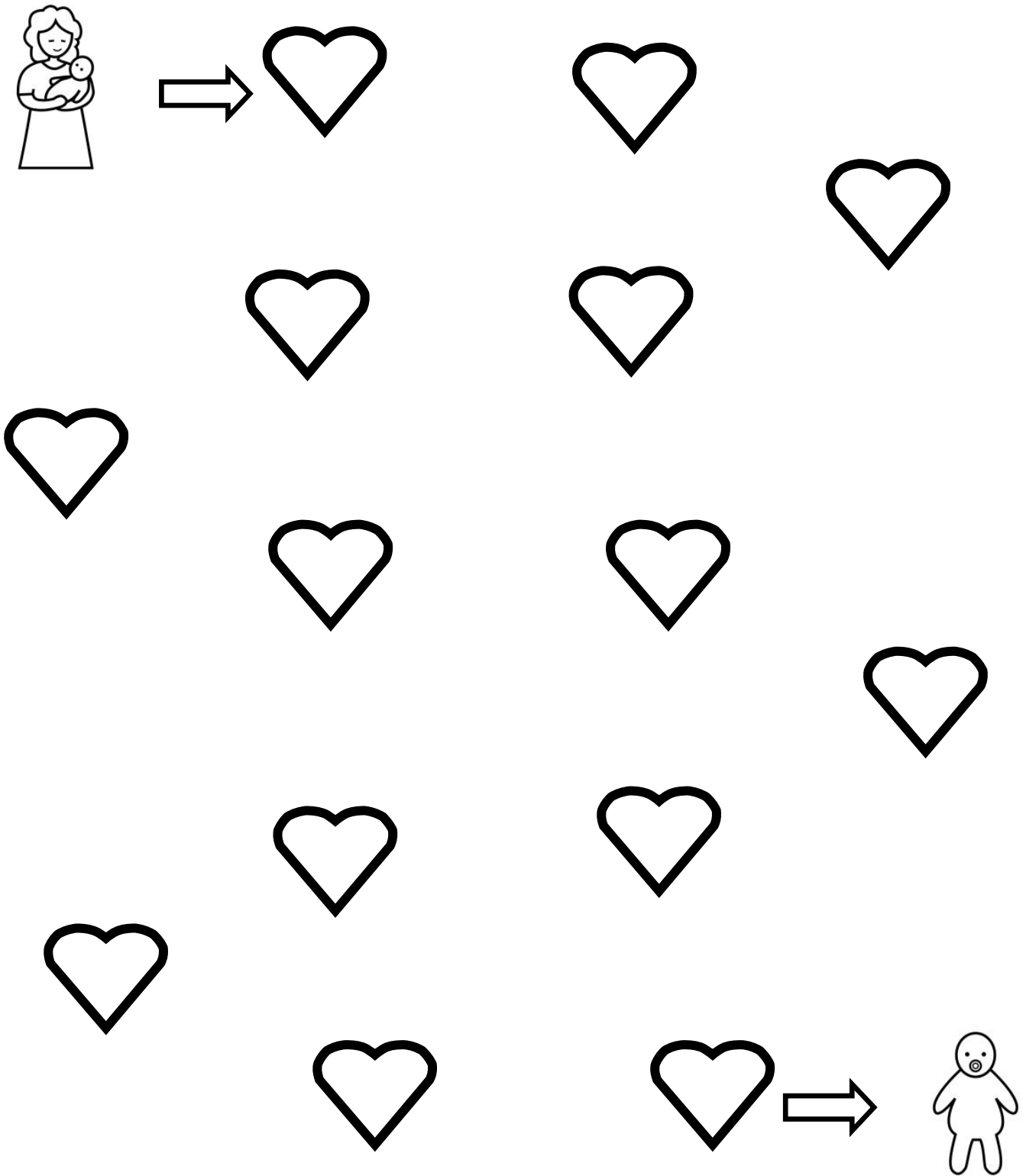

# Actividades para mejorar motricidad fina

Sigue las caras para unir al niño y a la niña

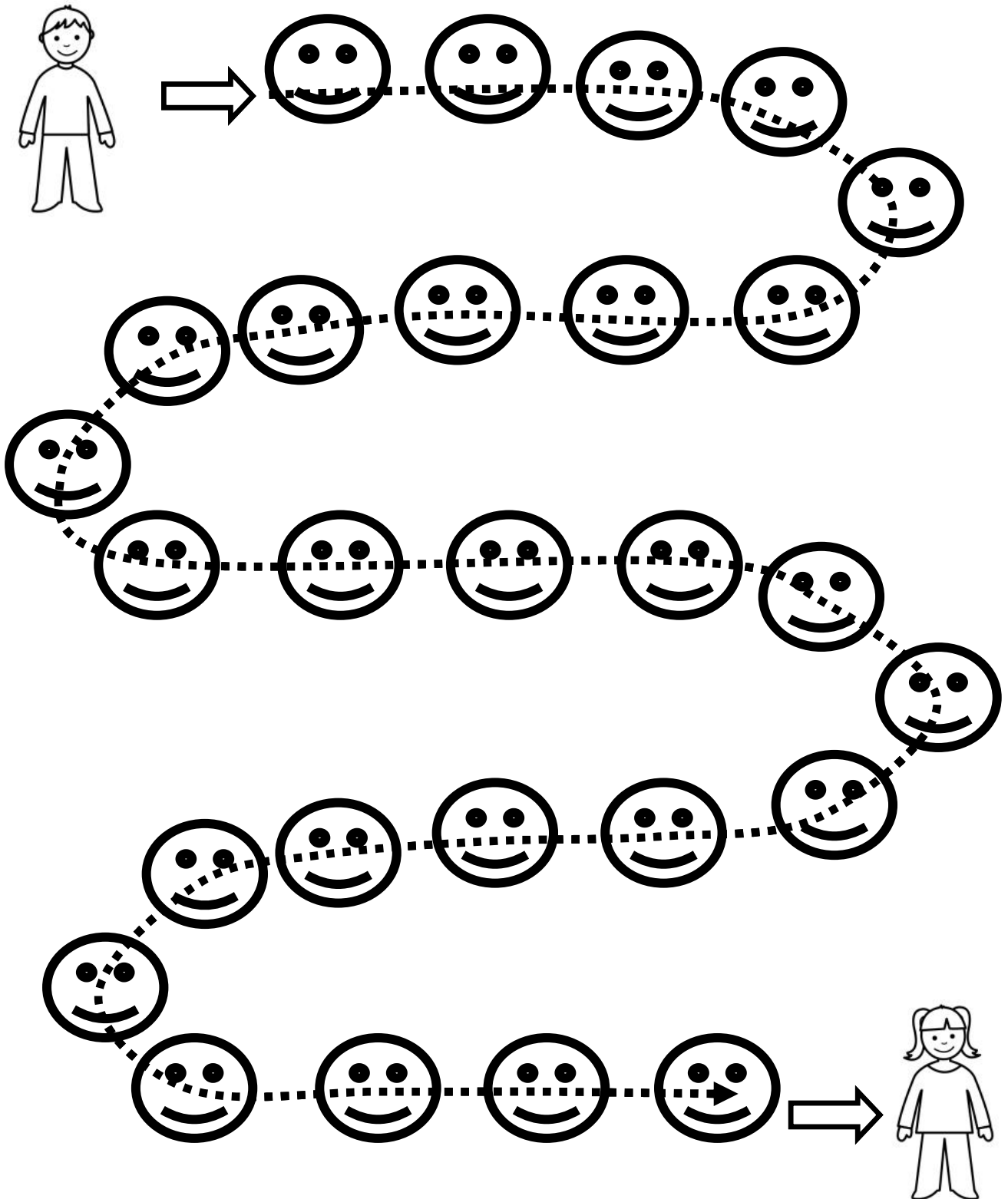

Actividades para mejorar motricidad fina

Sigue las caras para unir al niño y a la niña

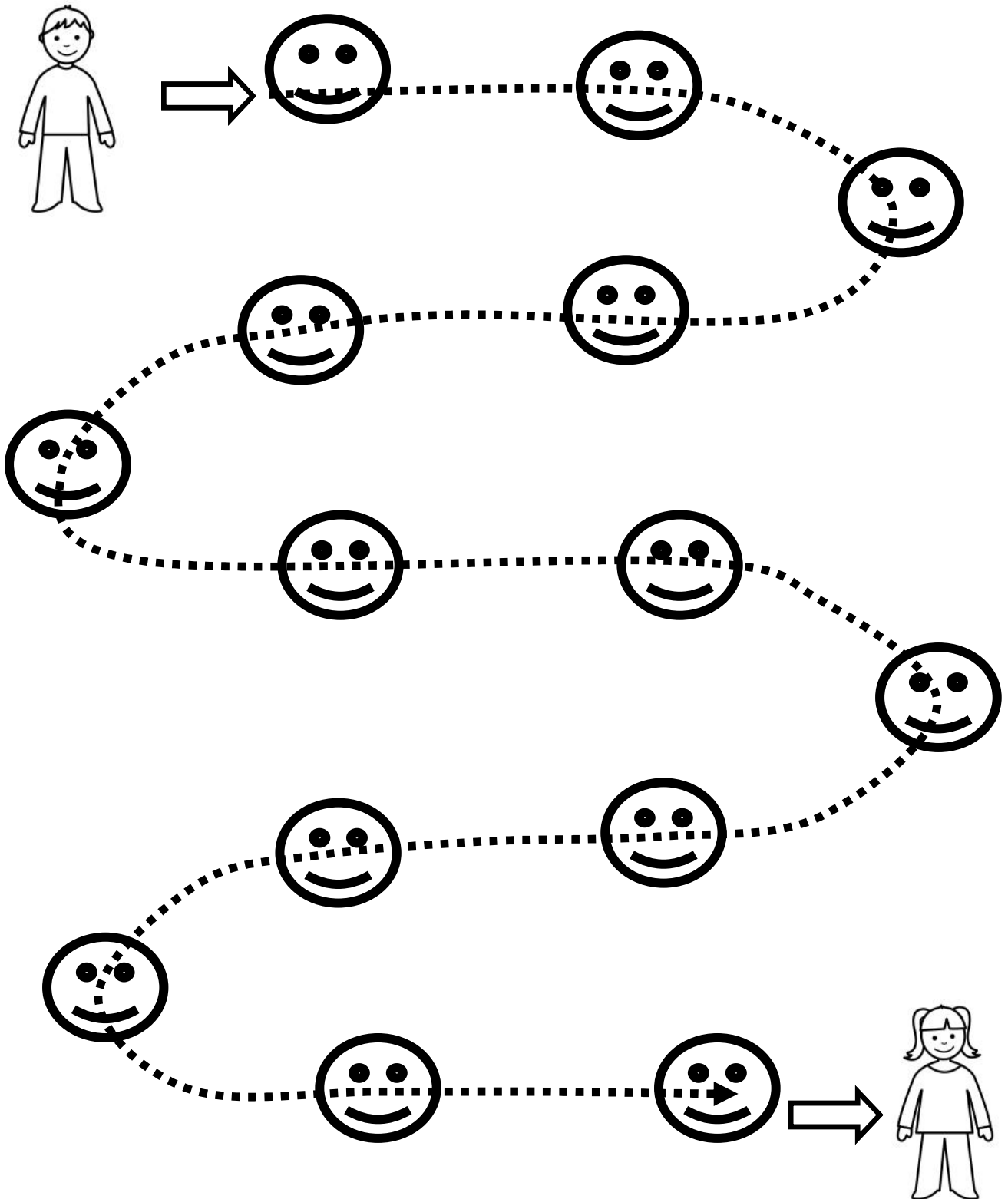

Actividades para mejorar motricidad fina

Sigue las caras para unir al niño y a la niña

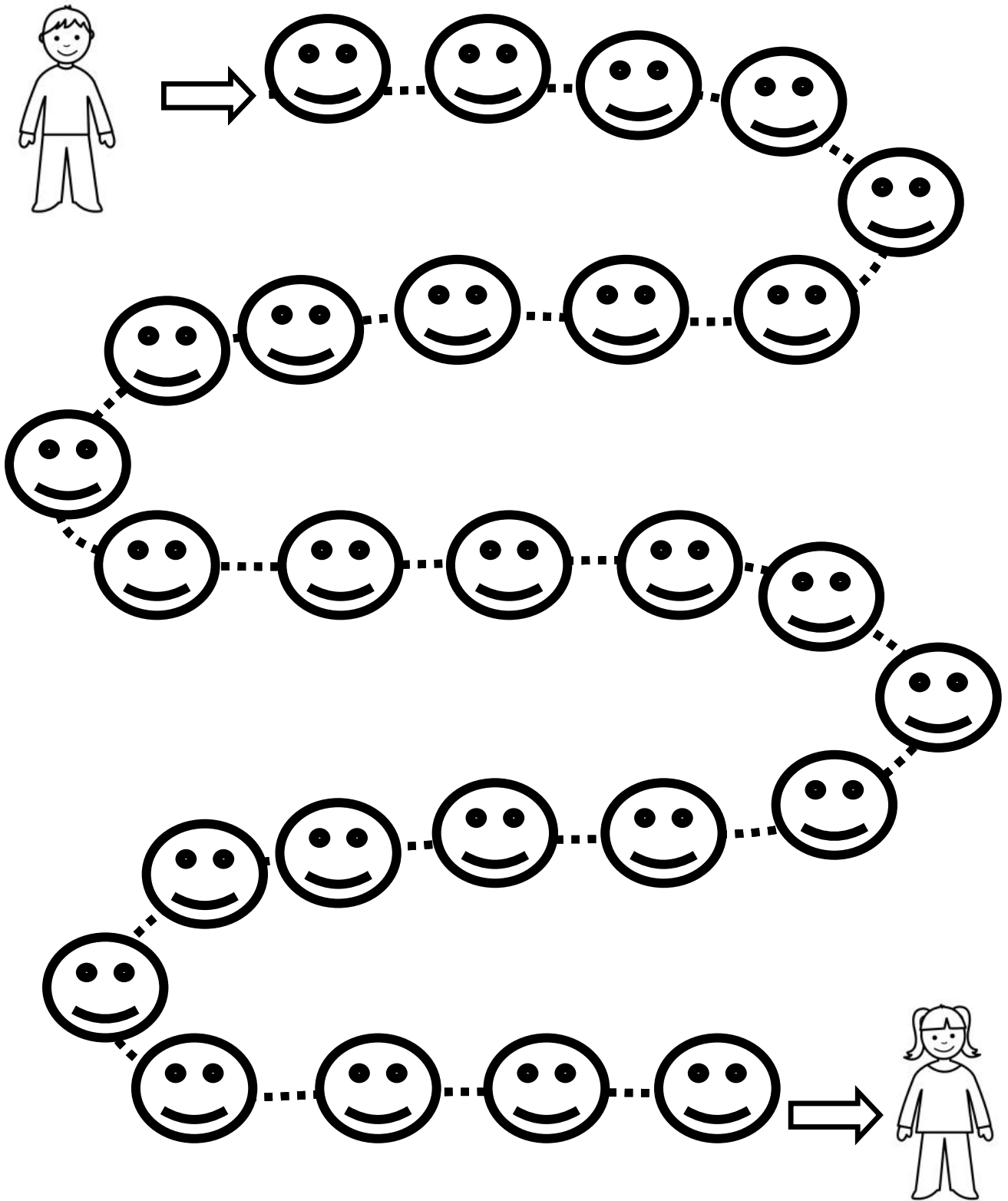



Actividades para mejorar motricidad fina

Sigue las caras para unir al niño y a la niña

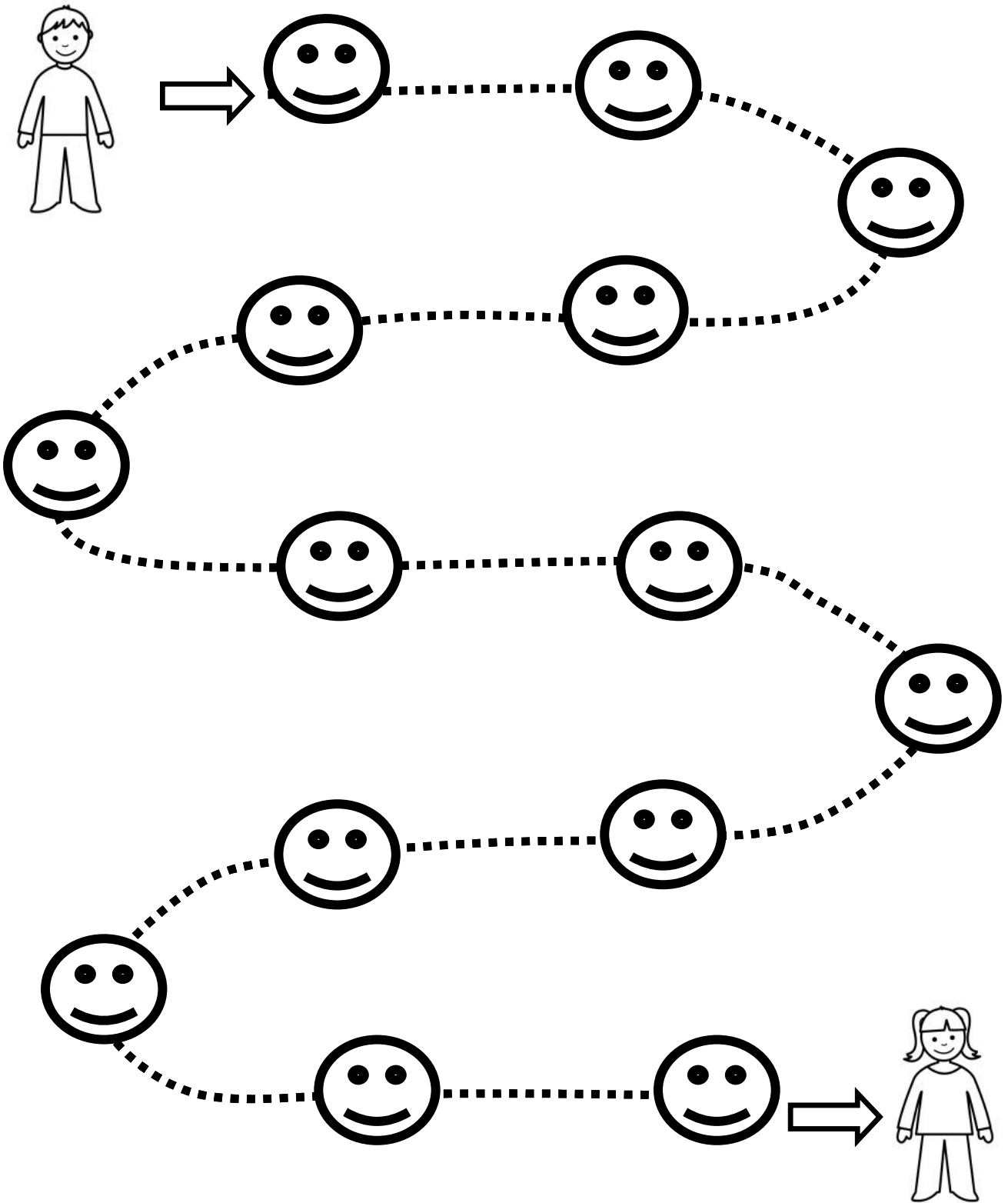

Actividades para mejorar motricidad fina

Sigue las caras para unir al niño y a la niña

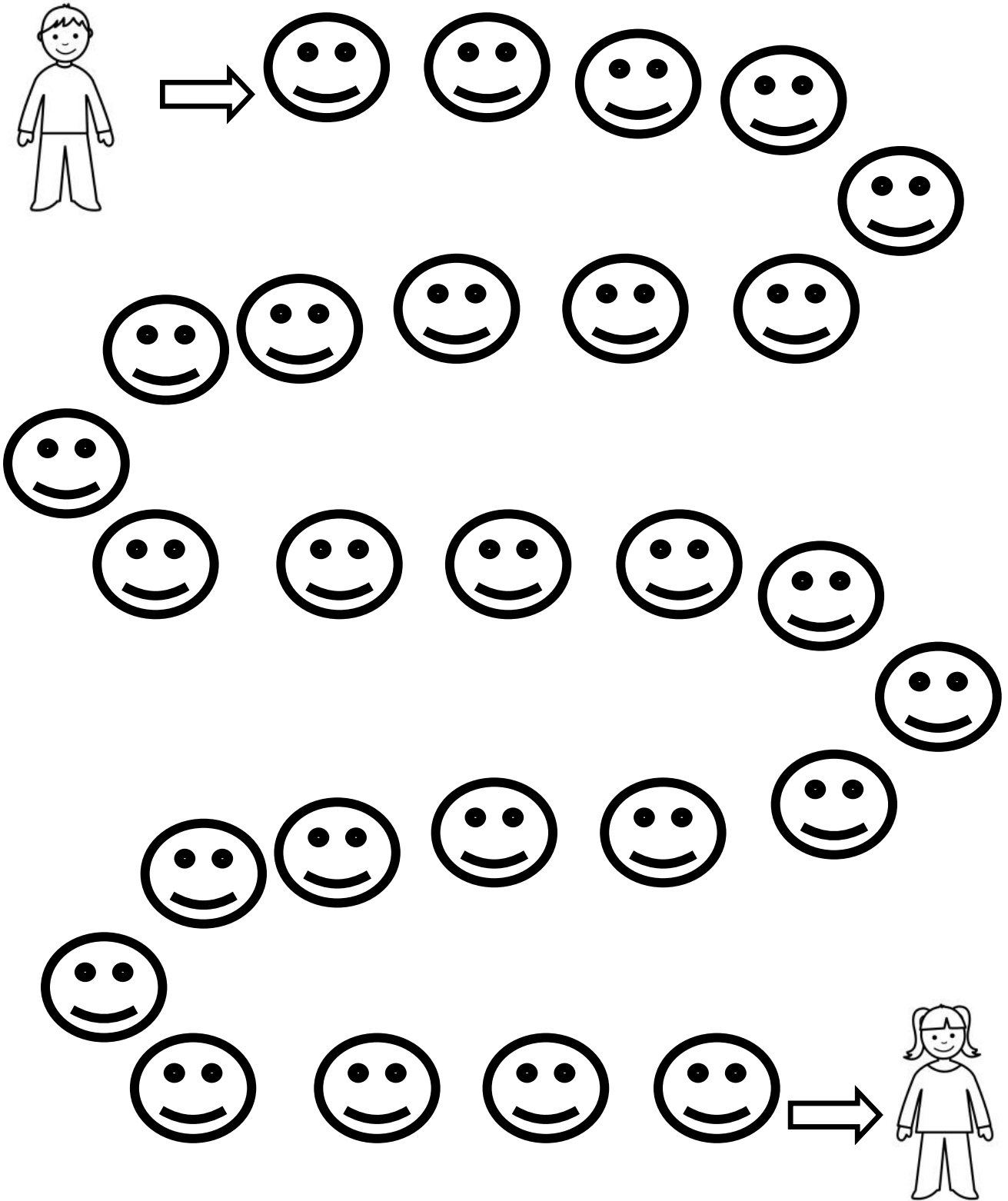

Actividades para mejorar motricidad fina

Sigue las caras para unir al niño y a la niña

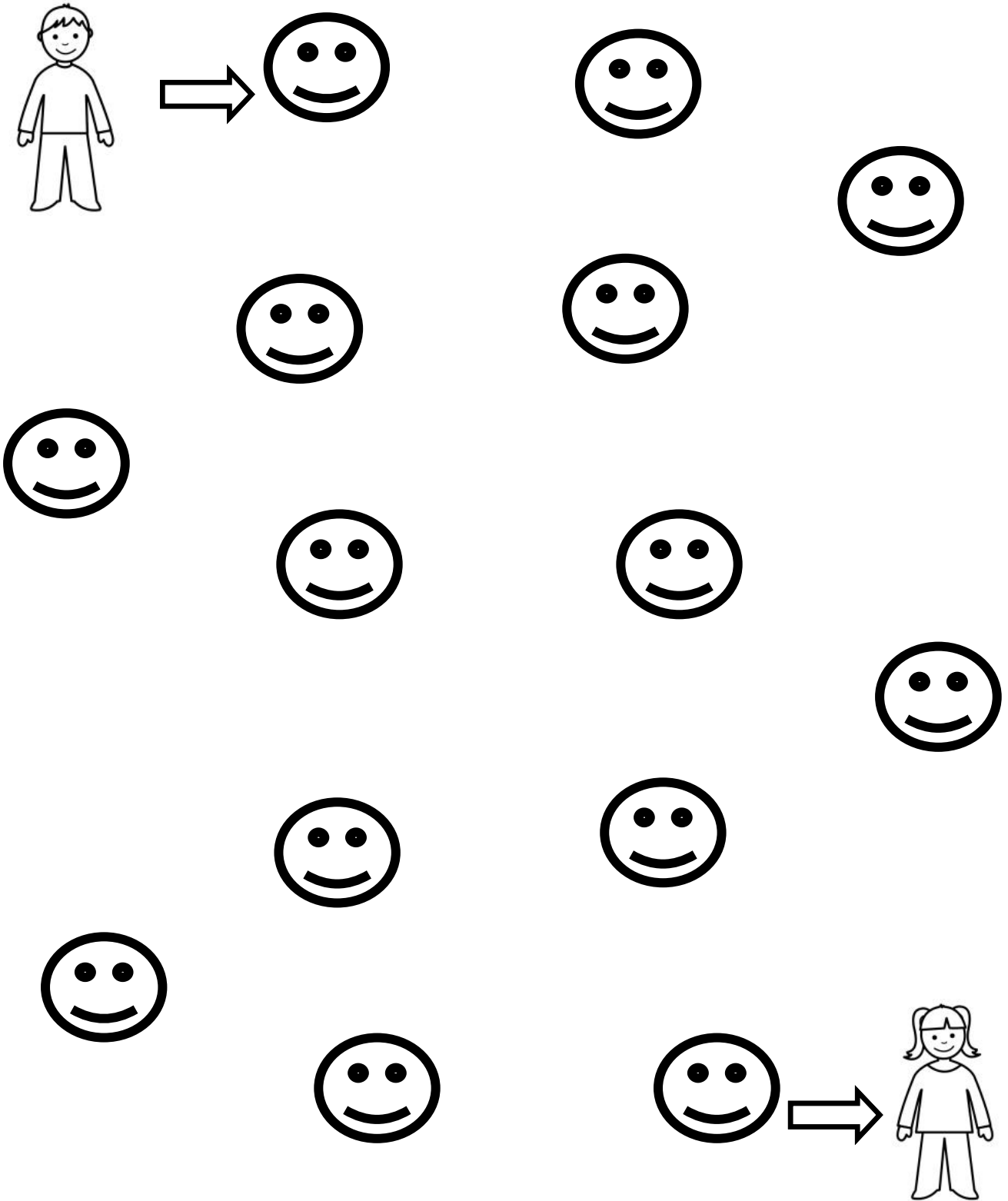

# Actividades para mejorar motricidad fina

Sigue los círculos para unir al niño con la pelota

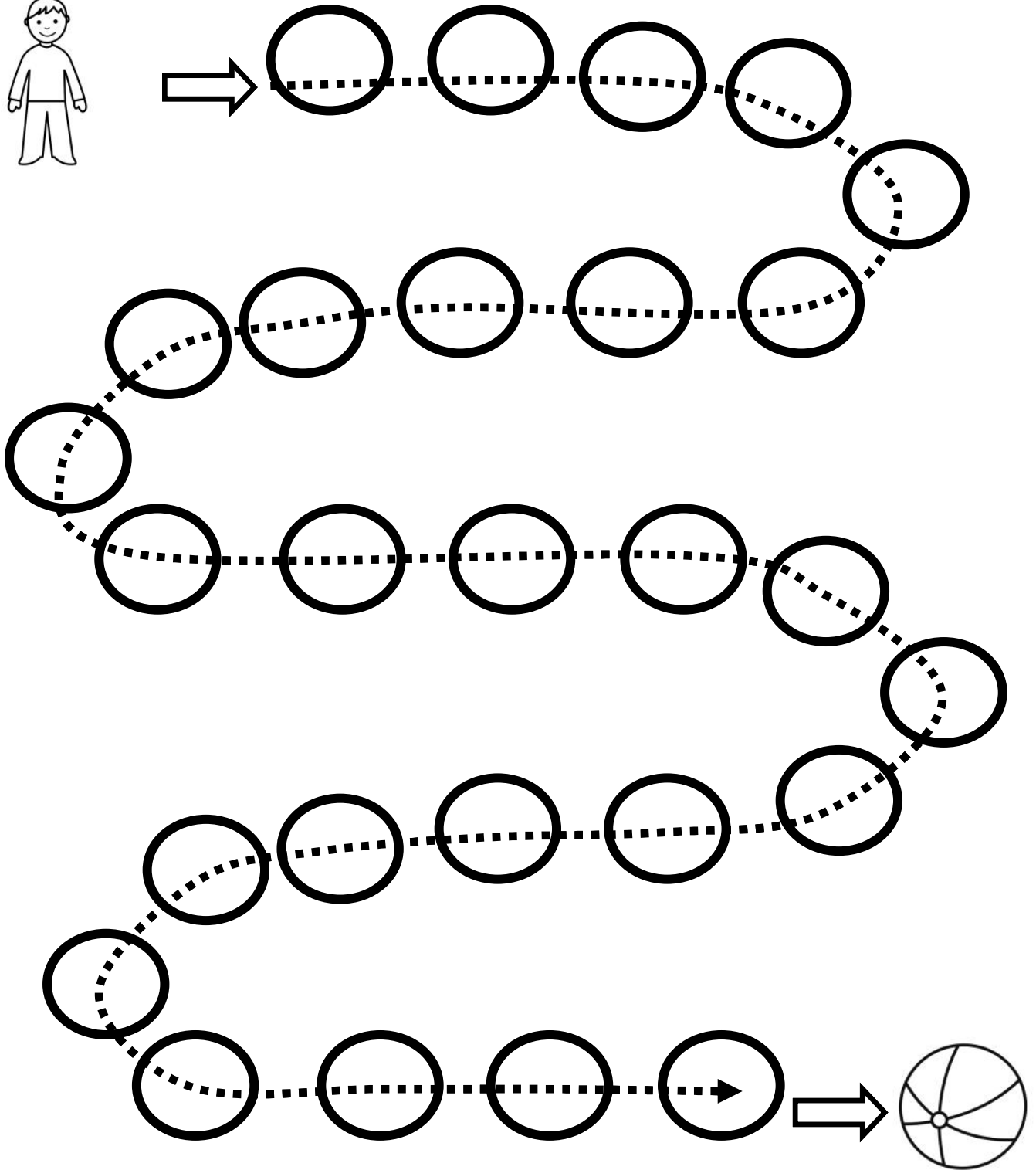
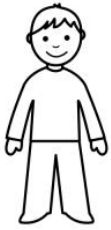

# Actividades para mejorar motricidad fina

Sigue los círculos para unir al niño con la pelota

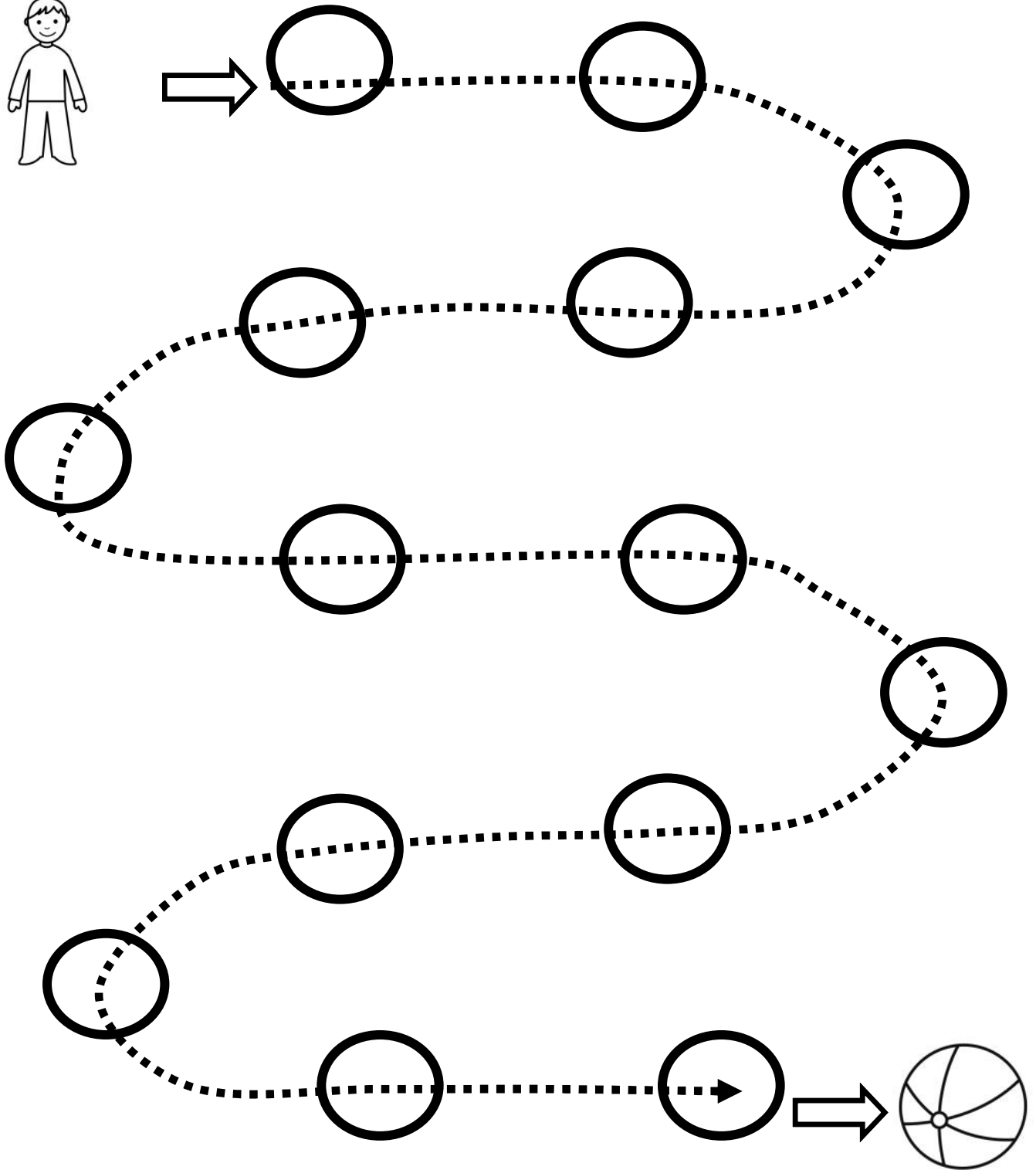
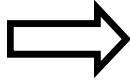
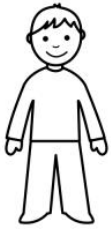

# Actividades para mejorar motricidad fina

Sigue los círculos para unir al niño con la pelota

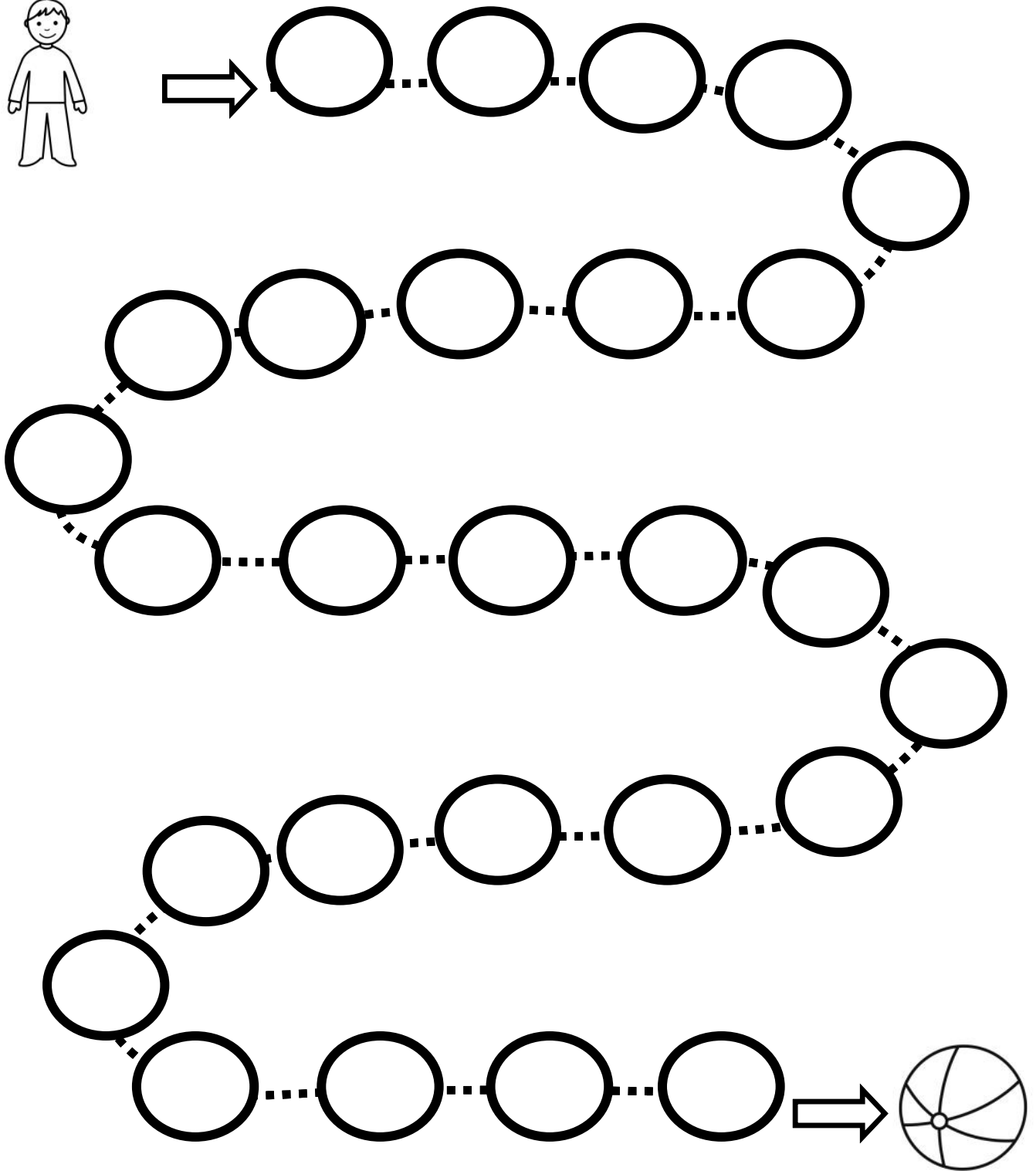
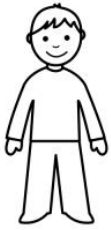

# Actividades para mejorar motricidad fina

Sigue los círculos para unir al niño con la pelota

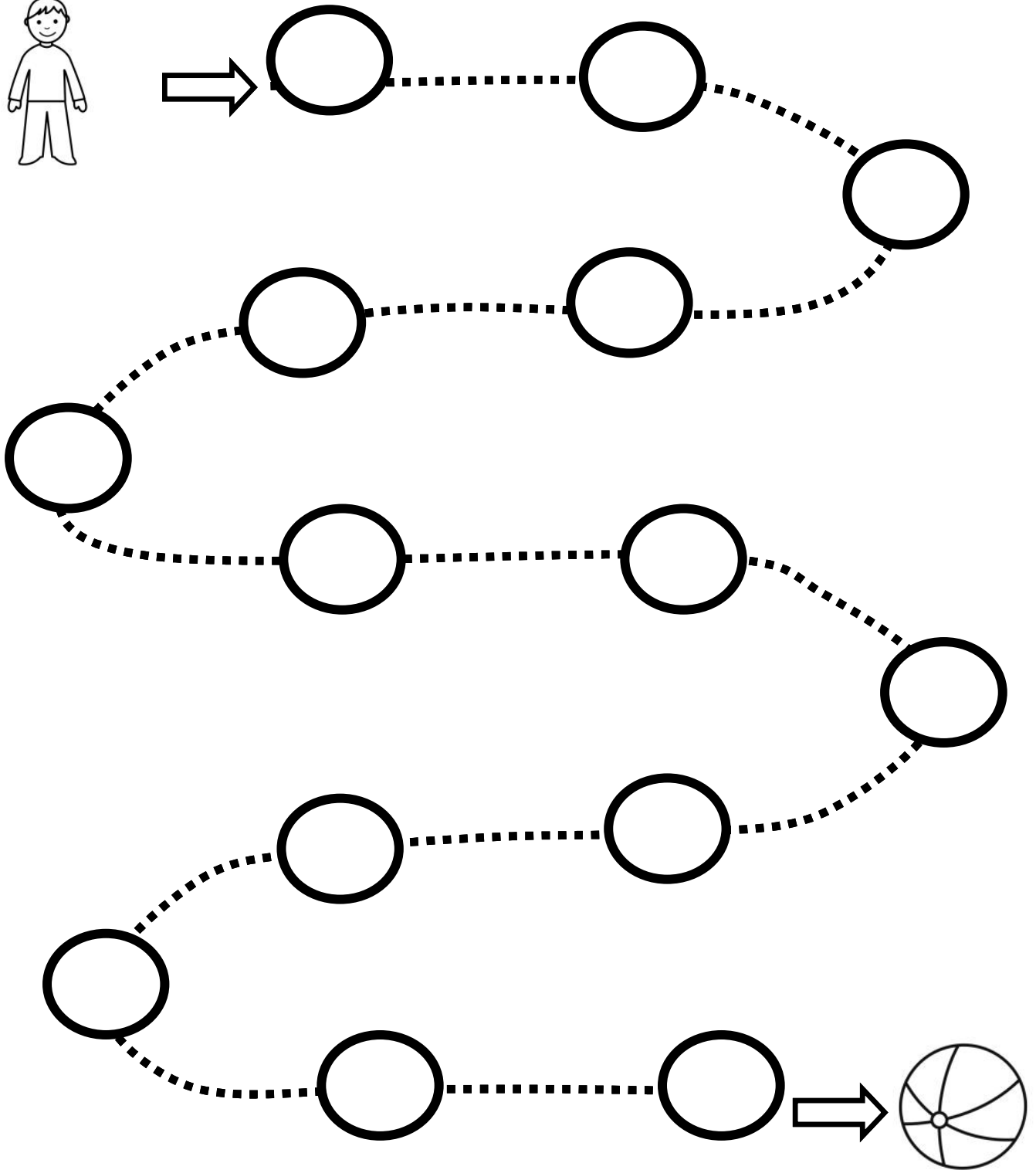
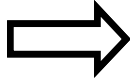
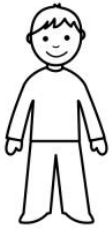

# Actividades para mejorar motricidad fina

Sigue los círculos para unir al niño con la pelota

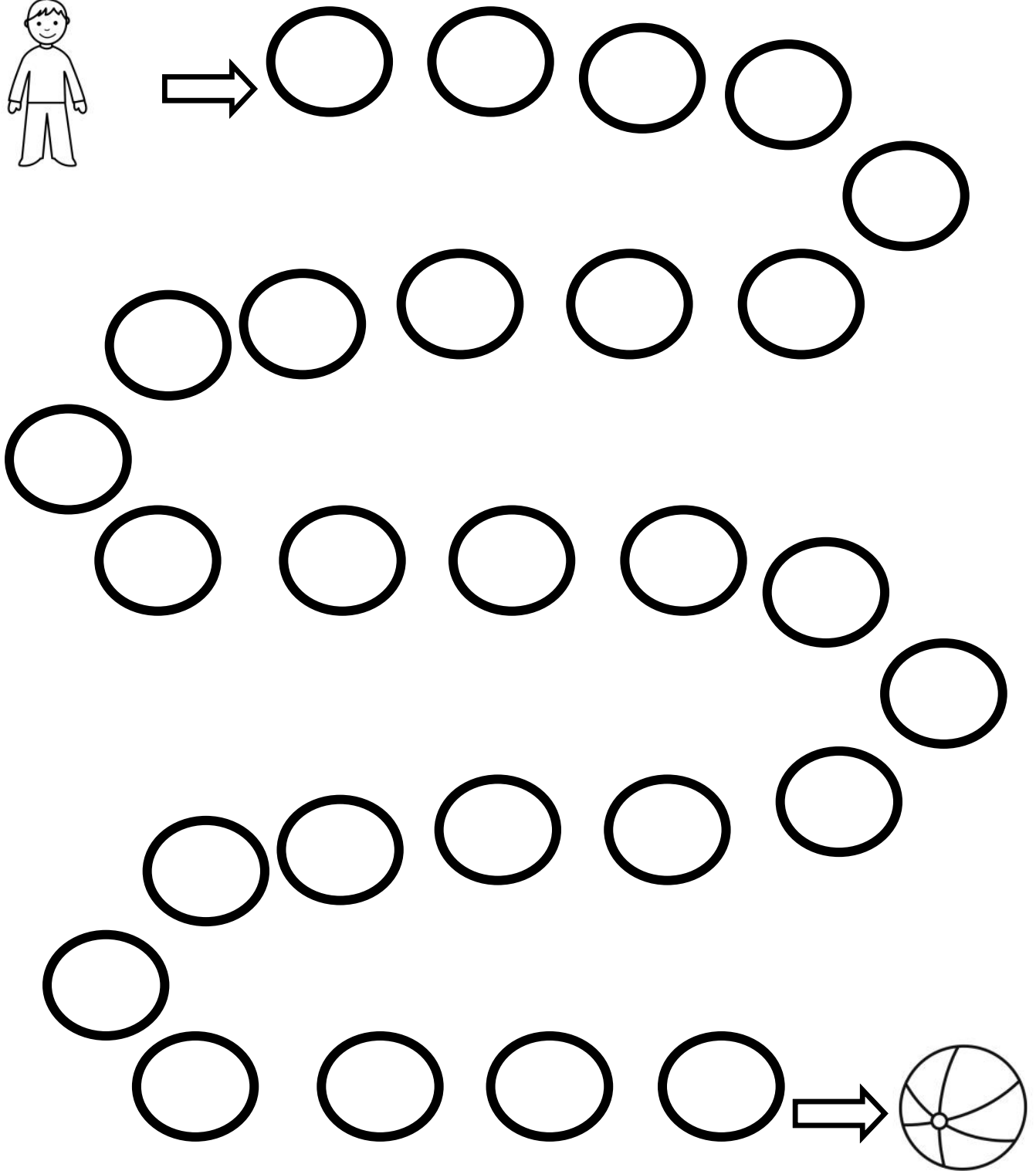
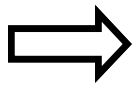
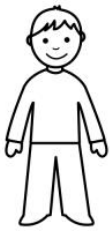



# Actividades para mejorar motricidad fina

Sigue los círculos para unir al niño con la pelota

